



FUEL INJECTION PERFORMANCE KIT

FIPK

GENERATION II™

INSTALLATION INSTRUCTIONS

57-6013

NISSAN

2003-06 350Z

V6-3.5L

NOTE: This kit was not designed to fit vehicles with a body lift.

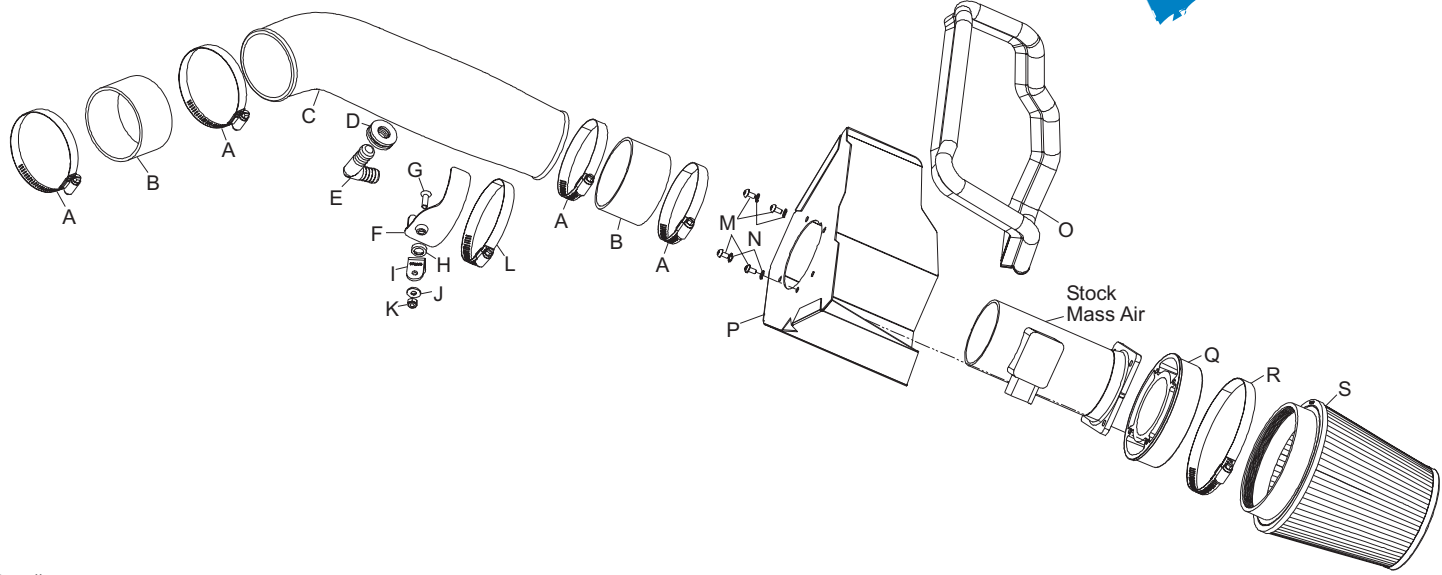

TOOLS NEEDED:

- Flat Blade Screwdriver
- Phillips Screwdriver
- Ratchet
- Extension
- 10mm Socket
- 4mm Allen

PARTS LIST:

Desc.	Qty.	Part #	Desc.	Qty.	Part #	Desc.	Qty.	Part #
A hose clamp #52	4	08610	F saddle bracket	1	078855	K nut; 6mm nylock	1	07553
B hose; 3.25" id x 2",	2	08690	G bolt; m6-1.00 x 20mm fha	1	08376	L hose clamp #56	1	08620
C intake tube (ET)	1	087161	H washer; conical, black, nylon	1	08180	M bolt; m6-1.00 x 16mm bha	4	07730
D grommet; 1-1/8" od x 5/8" id	1	08053	I bracket "L"	1	070066	N washer; 1/4" split lock	4	08198
E hose mender; 5/8" 90 deg	1	08072	J washer; 1/4" id x 5/8" od, flat	1	08275	O edge trim 42"	1	102499
						P heat shield	1	074036
						Q adapter #410	1	21514
						R hose clamp #80	1	08694
						S air filter	1	RF-1037

NOTE: FAILURE TO FOLLOW INSTALLATION INSTRUCTIONS AND NOT USING THE PROVIDED HARDWARE MAY DAMAGE THE INTAKE TUBE, THROTTLE BODY AND ENGINE.

TO START:

1. Turn the ignition OFF and disconnect the vehicle's negative battery cable.

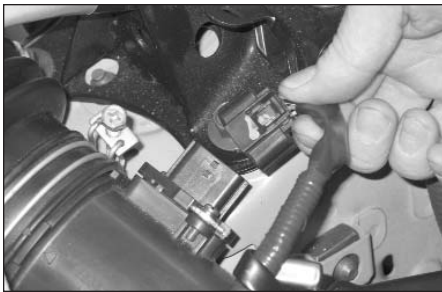

2. Depress the locking tab and disconnect the mass air sensor electrical connection. Next separate the mass air sensor wire harness from the clips, which attach to the air box.

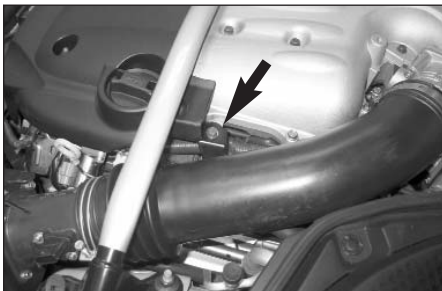

3. Remove the bolt, which secures the stock intake tube to intake manifold.

NOTE: Do not discard this bolt, as it will be used in a later step.



4. Loosen the two hose clamps, which secure the stock intake tube to the throttle body and air box. Then lift the intake tube up to access the crank case vent hose and disconnect the vent hose from the intake tube. Next remove the intake tube from the vehicle.

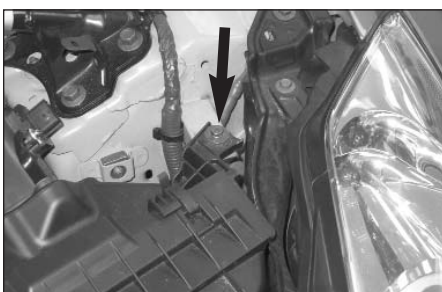

5. Remove the air box mounting bolt, which secures the air box to the inner fender.



6. Lift up on the air box to dislodge it from the mounting grommet and then remove the air box from the vehicle as shown.

NOTE: K&N recommends that customers do not discard factory air intake.



7. Install the provided edge trim onto the heat shield as shown.

NOTE: Some trimming of the edge trim may be necessary.

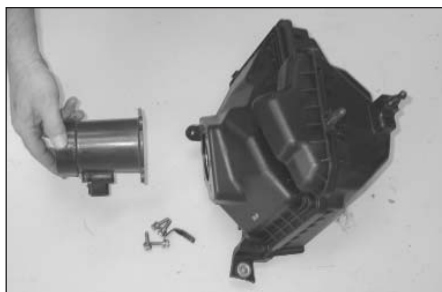

8. Remove the four bolts, which secure the mass air sensor to the factory air box and then separate the mass air sensor from the air box.



9. Remove the two screws, which secure the mass air sensor into the mass air housing, then remove the mass air sensor from the housing.

NOTE: Do not discard the mounting screws, as they will be reused in a later step.



10. Pass the mass air sensor housing through the heat shield as shown.



11. Using the provided hardware, assemble the mass air sensor housing and radiused filter adapter with heat shield together as shown.



12. Reinstall the mass air sensor into the mass air sensor housing with the factory screws removed in step #9.

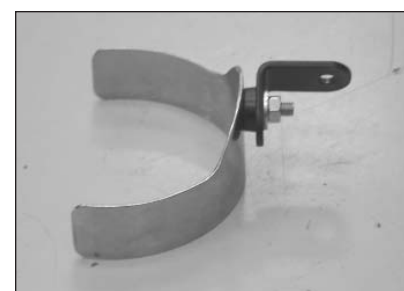

13. Using the provided hardware, install the saddle clamp onto the "L" bracket (070066) as shown.
NOTE: The slotted end of the "L" bracket will attach to the saddle clamp.



14. Install the saddle bracket assembly onto the engine using the bolt removed in step #3 as shown.



15. Install the provided grommet into the K&N intake as shown.



16. Install the provided 90 deg. fitting into the grommet that was installed onto the K&N intake tube in step #15.



17. Install the provided silicone hose (08690) onto the throttle body with the provided hose clamps as shown.



18. Install the K&N intake tube onto the throttle body and saddle clamp and then secure with the provided hose clamps as shown.
NOTE: Be sure to connect the crank case vent hose to the 90 deg. fitting in the K&N intake tube.



19. Install the silicone hose (08690) onto the end of the K&N intake tube with the provided hose clamps.

NOTE: Slide the hose all the way onto the intake tube to allow clearance for the mass air sensor installation.



20. Install the Filtercharger onto the radius filter adapter as shown.



21. Install the Filtercharger / mass air sensor assembly onto the K&N intake tube, slide the silicone hose onto the mass air sensor housing and secure with the provided hose clamp as shown.

NOTE: Adjust the assembly for proper fit before tightening the hose clamp.



22. Reconnect the mass air sensor electrical connection and secure the wiring harness to the heat shield in the hole provided.



23. Reconnect the vehicle's negative battery cable. Double check to make sure everything is tight and properly positioned before starting the vehicle.

24. The C.A.R.B. exemption sticker, (attached), must be visible under the hood so that an emissions inspector can see it when the vehicle is required to be tested for emissions. California requires testing every two years, other states may vary.

25. It will be necessary for all FIPK's to be checked periodically for realignment, clearance and tightening of all connections. Failure to follow the above instructions or proper maintenance may void warranty.

ROAD TESTING:

1. Start the engine with the transmission in neutral or park, and the parking brake engaged. Listen for air leaks or odd noises. For air leaks secure hoses and connections. For odd noises, find cause and repair before proceeding. This kit will function identically to the factory system except for being louder and much more responsive.

2. Test drive the vehicle. Listen for odd noises or rattles and fix as necessary.

3. If road test is fine, you can now enjoy the added power and performance from your kit.

4. K&N suggests checking the Filtercharger element periodically for excessive dirt build-up. When the element becomes covered in dirt (or once a year), service it according to the instructions on the Recharger service kit, part number 99-5050 or 99-5000.