

ALUMINUM RUNNING BOARD INSTALLATION PAGE 1

STANDARD INSTALLATION FOR ALL VEHICLES (NOTE) THE BRACKET SYSTEMS ARE UNIQUE TO YOUR VEHICLE, SEE BRACKET ASSEMBLY SUGGESTIONS BELOW AND LOCATIONS ON THE BACK PAGE

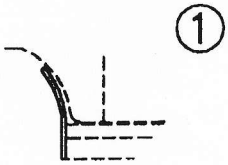

①
BEND STONE GUARDS BY HAND AND KNEE TO FIT THE WHEEL WELL.

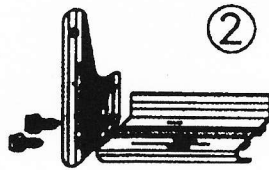

②
FASTEN FRONT STONE GUARD TO BOARDS WITH 3/8" SELF TAPPING BOLT.



③
SLIDE ONE OR TWO 1/4" x 5/8" SQUARE HEAD SCREWS INTO EACH TRACK (1 SET PER BRACKET) REFER TO DRAWINGS 11-14 FOR BRACKET LOCATION AND QUANTITY

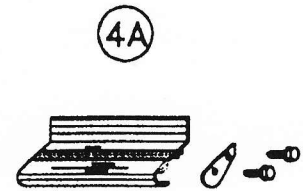

④A
CAB LENGTH BOARDS
INSTALL END CAP TO BOARD WITH 3/8" SELF TAPPING BOLT

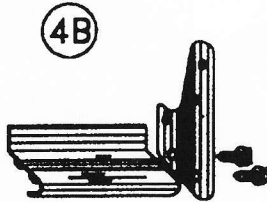

④B
FULL LENGTH BOARDS
BEND STONE GUARD BY HAND AND KNEE TO FIT WHEEL WELL.
FASTEN REAR STONE GUARD TO BOARDS WITH 3/8" SELF TAPPING BOLTS.

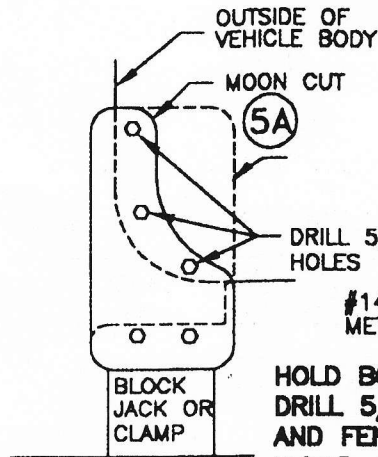

⑤A
OUTSIDE OF VEHICLE BODY
MOON CUT
DRILL 5/32" HOLES
#14x3/4 SHEET METAL SCREW
BLOCK JACK OR CLAMP
HOLD BOARD IN PLACE WITH BLOCKS OR CLAMPS
DRILL 5/32" HOLES THROUGH THE STONE GUARD AND FENDER WELL. ENLARGE THE STONE HOLE TO 7/32". FASTEN THE STONE GUARD TO THE VEHICLE WITH #14x3/4" SHEET METAL SCREWS.

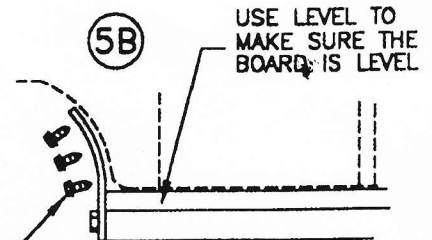

⑤B
USE LEVEL TO MAKE SURE THE BOARD IS LEVEL

TYPICAL BRACKET ASSEMBLY

SUGGESTED BRACKET ASSEMBLYS, USE WHICH EVER FITS YOUR VEHICLE BEST

TYPICAL OLD FORD 87-96

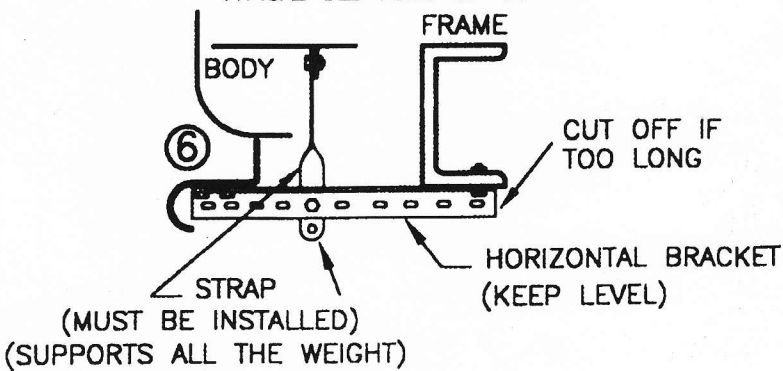

TYPICAL NEW FORD/GMC 96-CURRENT

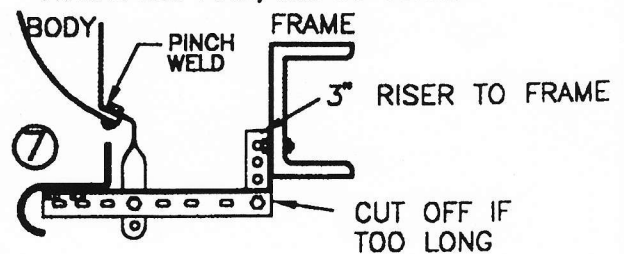

TYPICAL DODGE

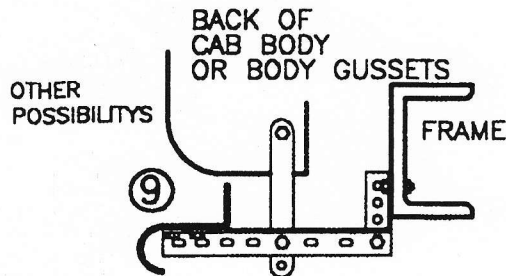
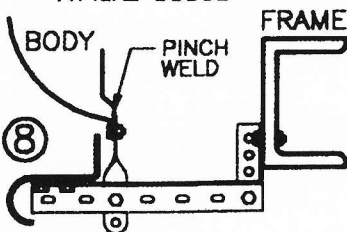

SEE BACK PAGE FOR TYPICAL BRACKET MOUNT LOCATIONS

10 TYPICAL SCREW TYPE AND APPLICATION

5/16" NUT AND BOLT

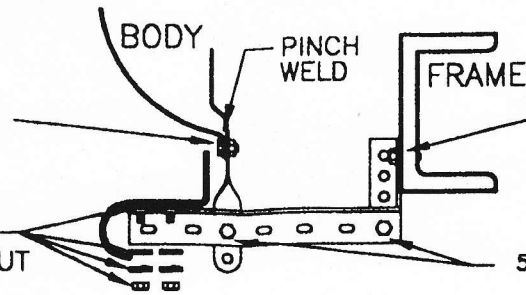

5/16" SELF TAPPING BOLT. DRILL A 9/32" PILOT HOLE

1/4" SQUARE HEAD BOLT, FLAT WASHER, LOCK WASHER AND NUT

5/16" NUT AND BOLT

11

TYPICAL CAB LENGTH STD. CAB INSTALLATION

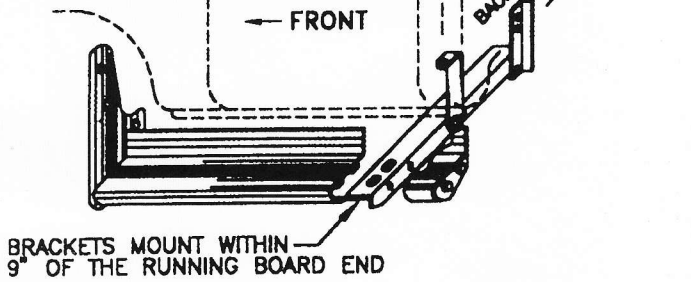

BRACKETS MOUNT WITHIN 9" OF THE RUNNING BOARD END

12

TYPICAL CAB LENGTH EXTENDED OR DOUBLE CAB INSTALLATION

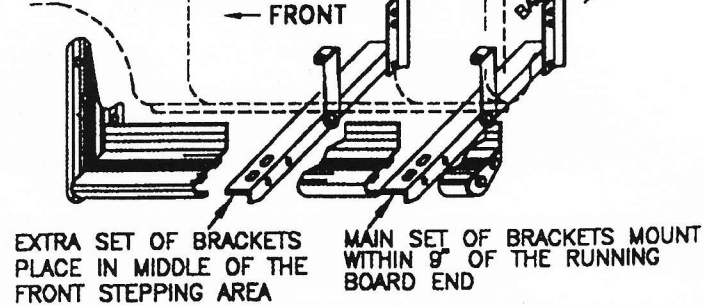

EXTRA SET OF BRACKETS PLACE IN MIDDLE OF THE FRONT STEPPING AREA

MAIN SET OF BRACKETS MOUNT WITHIN 9" OF THE RUNNING BOARD END

13

TYPICAL FULL LENGTH STD. CAB PICKUP AND VAN INSTALLATION

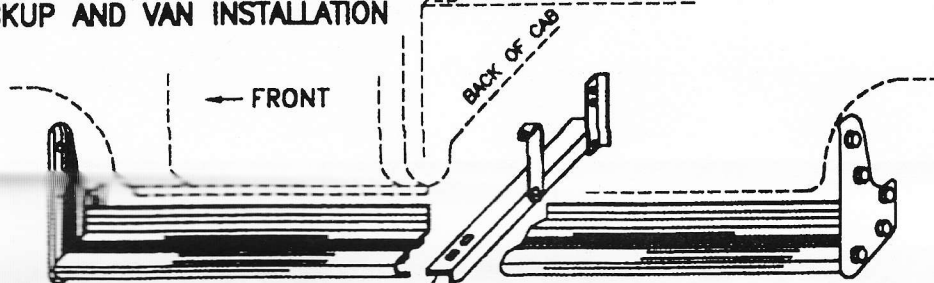

BRACKETS MOUNT AROUND THE BACK OF THE CAB ON PICKUPS (NOT ON THE BOX) OR AROUND THE MIDDLE OF A VAN BOARD.

TYPICAL FULL LENGTH EXTENDED OR DOUBLE CAB PICKUP AND VAN INSTALLATION

14

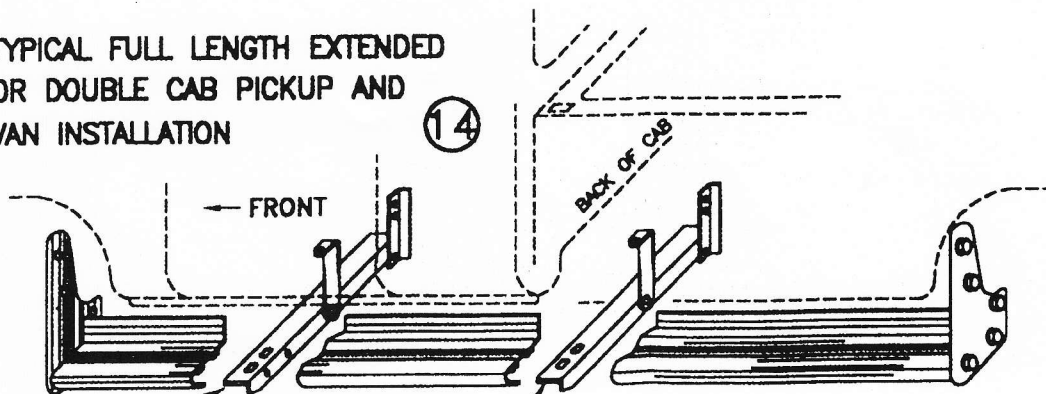

EXTRA SET OF BRACKETS PLACE IN MIDDLE OF THE FRONT STEPPING AREA

MAIN SET OF BRACKETS MOUNT AROUND THE BACK OF THE CAB ON PICKUPS OR AROUND THE MIDDLE OF A VAN BOARD.

STANDARD INSTALLATION FOR ALL VEHICLES (NOTE) THE BRACKET SYSTEMS ARE UNIQUE TO YOUR VEHICLE, SEE BRACKET ASSEMBLY SUGGESTIONS BELOW AND LOCATIONS ON THE BACK PAGE

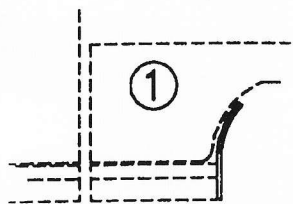

①
BEND STONE GUARDS BY HAND AND KNEE TO FIT THE WHEEL WELL.

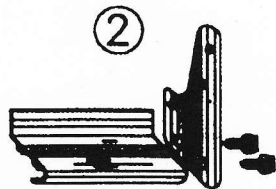

②
FASTEN REAR STONE GUARD TO BOARDS WITH 3/8" SELF TAPPING BOLT.

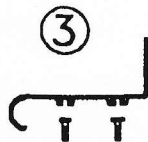

③
SLIDE ONE 1/4" x 5/8" SQUARE HEAD SCREWS INTO EACH TRACK REFER TO DRAWINGS 11-12 FOR BRACKET LOCATION

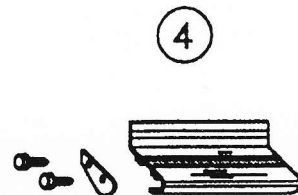

④
INSTALL END CAP TO BOARD WITH 3/8" SELF TAPPING BOLT

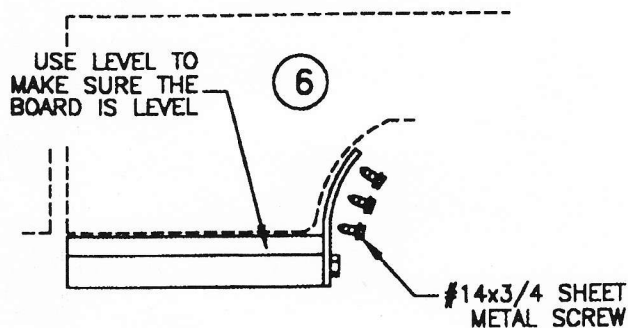
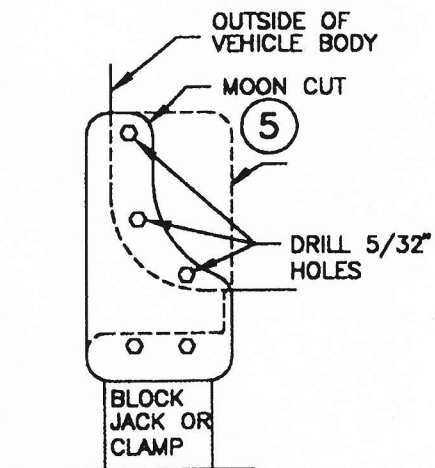

HOLD BOARD IN PLACE WITH BLOCKS OR CLAMPS DRILL 5/32" HOLES THROUGH THE STONE GUARD AND FENDER WELL ENLARGE THE STONE HOLE TO 7/32". FASTEN THE STONE GUARD TO THE VEHICLE WITH #14x3/4" SHEET METAL SCREWS.

TYPICAL BRACKET ASSEMBLY

SUGGESTED BRACKET ASSEMBLYS, USE WHICH EVER FITS YOUR VEHICLE BEST

TYPICAL OLD FORD 87-96

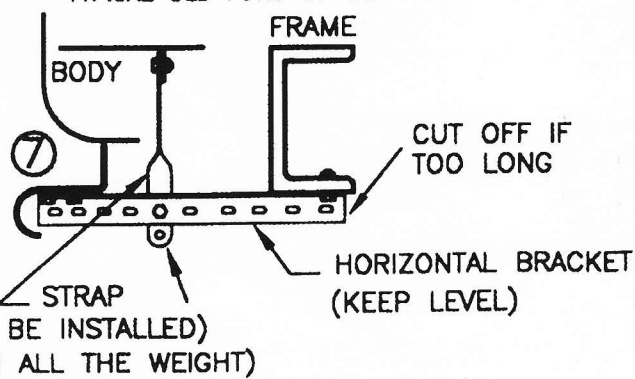

TYPICAL NEW FORD/GMC 96-CURRENT

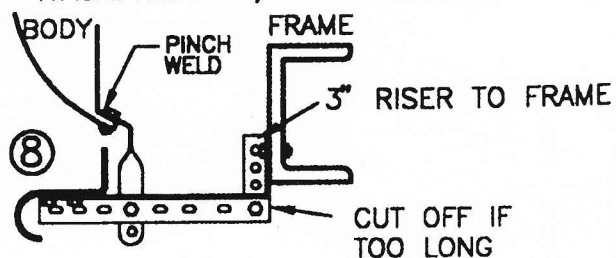

TYPICAL DODGE

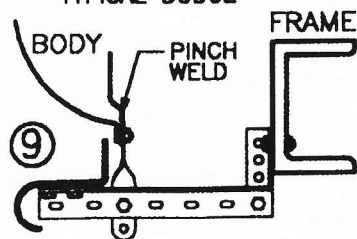

OTHER POSSIBILITIES

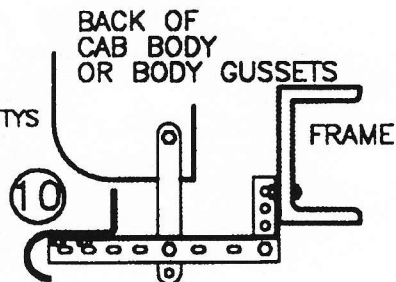

SEE BACK PAGE FOR TYPICAL BRACKET MOUNT LOCATIONS

11 TYPICAL SCREW TYPE AND APPLICATION

5/16" NUT AND BOLT

1/4" SQUARE HEAD BOLT, FLAT WASHER, LOCK WASHER AND NUT

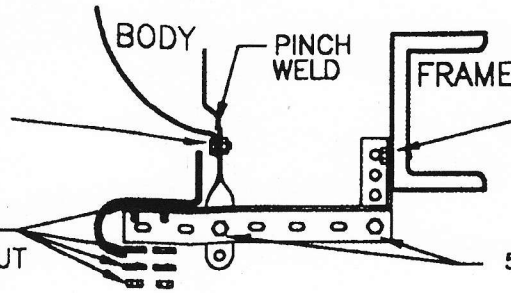

5/16" SELF TAPPING BOLT. DRILL A 9/32" PILOT HOLE

5/16" NUT AND BOLT

12

BED INSTALLATION

FRONT

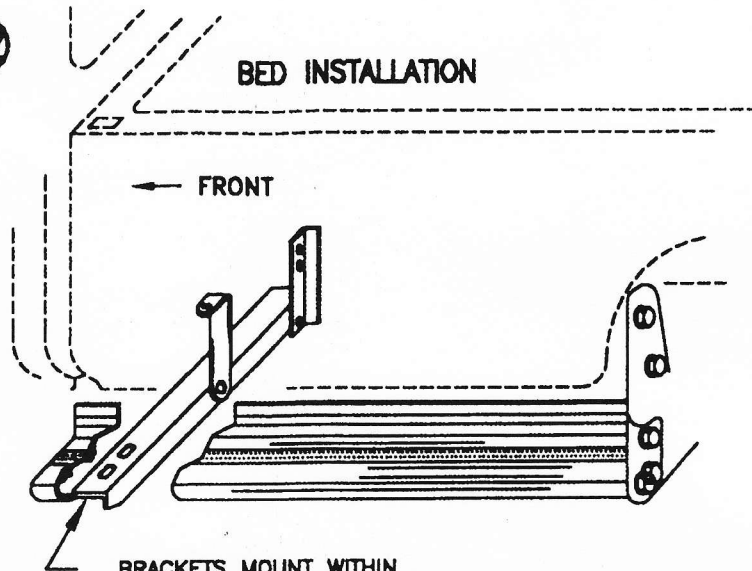

BRACKETS MOUNT WITHIN 9" OF THE RUNNING BOARD END

UNIVERSAL DUALY BOARD INSTALLATION

DUALYS MOUNT SIMILAR TO THE BOX BOARDS BUT WILL USE TWO SETS OF BRACKETS

13

DUALY BED

FRONT

9" STRAP

24" HORIZONTAL BRACKET

15" STRAP

ONLY FASTEN THE STONE GUARDS TO STEEL FENDERS OR STEEL FENDER SUPPORTS, IT IS NOT RECOMMENDED TO SCREW INTO FIBERGLASS OR PLASTIC FENDERS. TO PREVENT DAMAGE USE TAPE TO STOP RUBBING OR VIBRATION NOISES

30" HORIZONTAL BRACKET MOUNT THIS BRACKET AS FAR TO THE REAR AS POSSIBLE. TYPICALLY ABOUT 4" FROM THE REAR ON CHEVY AND GMC'S AND 6" TO 10" ON FORD TRUCKS.

BRACKETS MOUNT WITHIN 9" OF THE RUNNING BOARD END