

1 Scope of Delivery

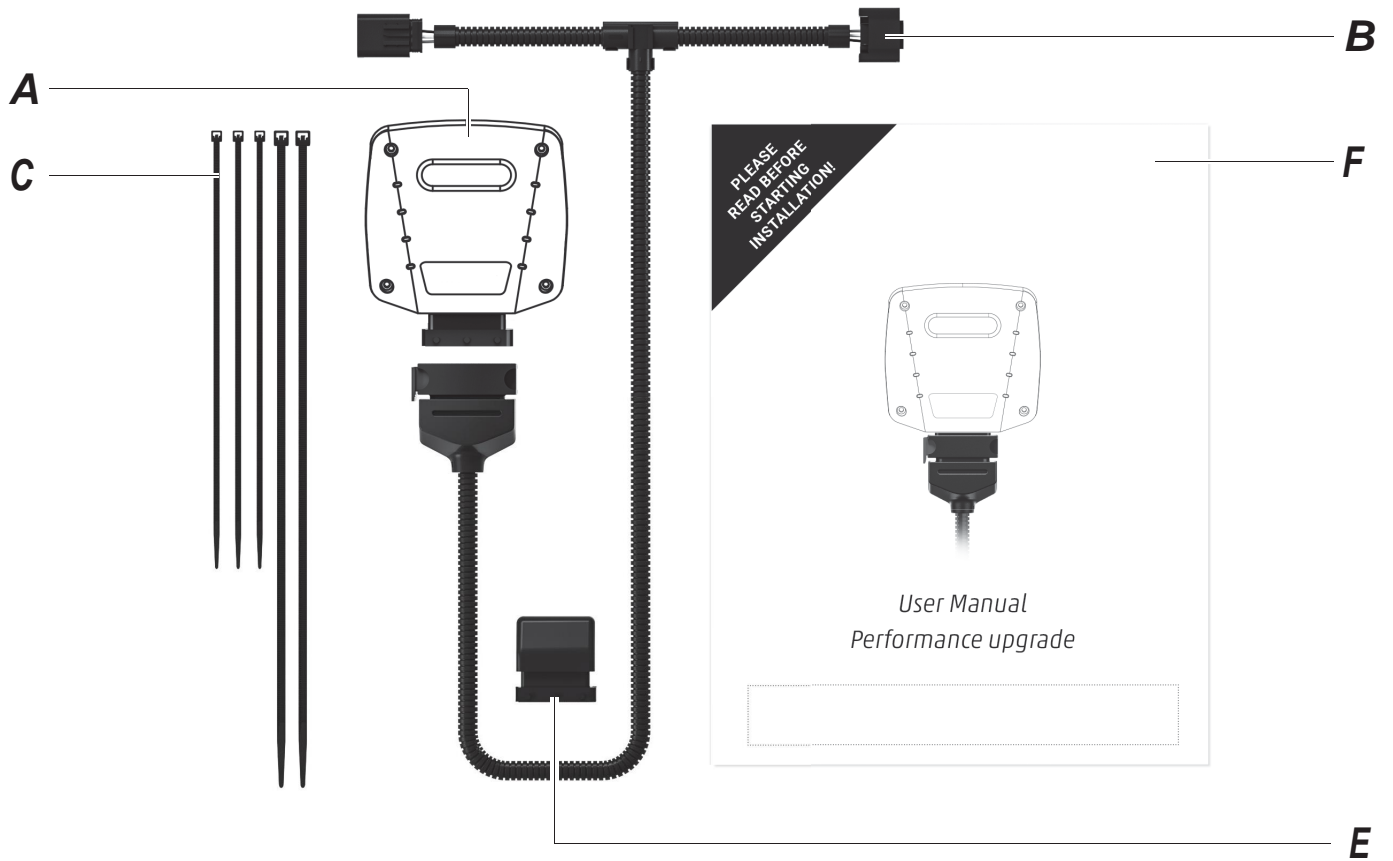

A *Performance upgrade*
calibrated specifically for your vehicle

B *Wiring harness*
automobile-grade, compatible with your vehicle ⁽¹⁾

C *Cable ties*
to mount the Performance upgrade and the wiring harness
2 x long cable ties
3 x short cable ties

E *Deactivation plug*
returns your engine to stock tune

F *User Manual*
installation and operation

⁽¹⁾ Picture may differ from delivered product.

2 Overview of the performance upgrade

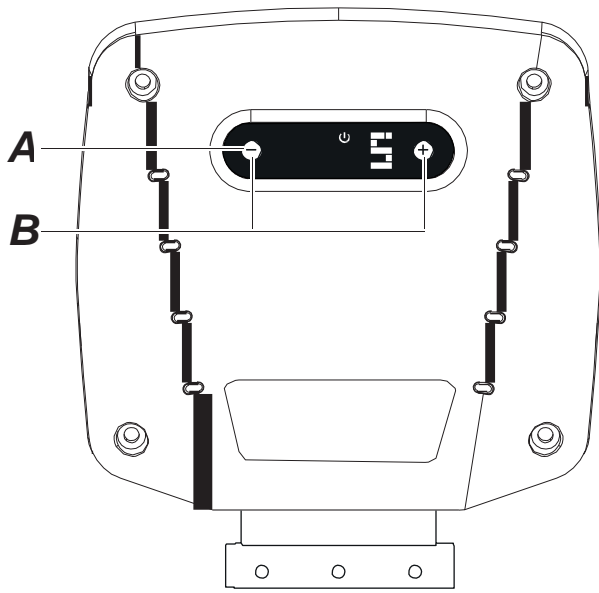

A Digital User Interface for controlling the performance upgrade.

B +/- buttons for changing the mapping (see *Fine tuning*)

C Power ON light; lights only when the vehicle ignition is on and power is being supplied to the performance upgrade.

D Display showing mapping selected (see *Fine tuning*).

E Slots for cable ties to mount the product

F FCI plug for connecting to the vehicle's wiring.

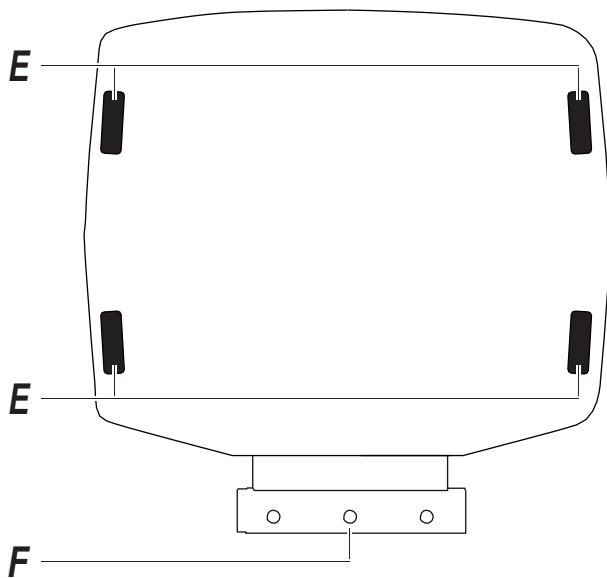
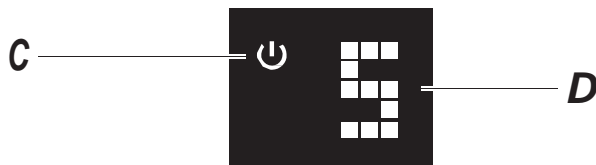

3 Installation

Step 1 - Preparation

⚠ WARNING Before installing the tuning module, please wait for your engine to cool down. Otherwise there is a risk of sustaining burns.



Put on the parking brake (emergency brake) before starting installation.



If an **alarm system** is fitted: disable the alarm before starting installation. For further instructions, check the manual of the car manufacturer.



Some cars **will not lock completely** if the hood is open and electrical consumers are still active. If this is the case with your car, push the hood catch over manually, lock the car again and wait ca. 15 minutes. When you have finished the installation, do not forget to release the catch again by pulling the hood release lever.



Turn the ignition off and lock your vehicle. For cars with "**Keyless Go**": after locking the car, place the key out of signal range (about 11 yards or 10 meters from the car).



After locking the vehicle, **wait about 10 minutes** before starting *Step 2*, as all current consumers must have switched themselves off.



Generally speaking, you do not require special tools to perform the installation. If you need a tool, we will tell you when you get to the relevant step in these instructions. You will probably find wire cutters useful for clipping off the loose ends of cable ties.



- If you have any questions or difficulties during the installation, please refer to **Trouble Shooting** for hints and tips.

3 Installation

NOTICE If you do not wait for at least 10 minutes, electrical voltage and signal flow may still be present in the connections. Detaching the connectors while electronic signals still flow, may damage your vehicle.

NOTICE Never turn on the ignition while connectors are disconnected. Risk of check light on the dashboard!

NOTICE Disconnecting the battery may damage your vehicle. Do not disconnect the battery at any time, if not otherwise prompted in the instruction manual.

NOTICE If stock parts must be dismantled, please check vehicle manufacturer manual for tightening torques.

NOTICE To avoid damages at electronic vehicle components, you have to be sure that you have done all necessary methods for electrostatic discharge.

NOTICE Tuning modules are developed, produced and tested for vehicles in stock condition.

NOTICE Using 3rd-party on-board diagnostic (OBD) scan tools may damage your vehicle. Do not use them.

3 Installation

Step 2 - Connector locations

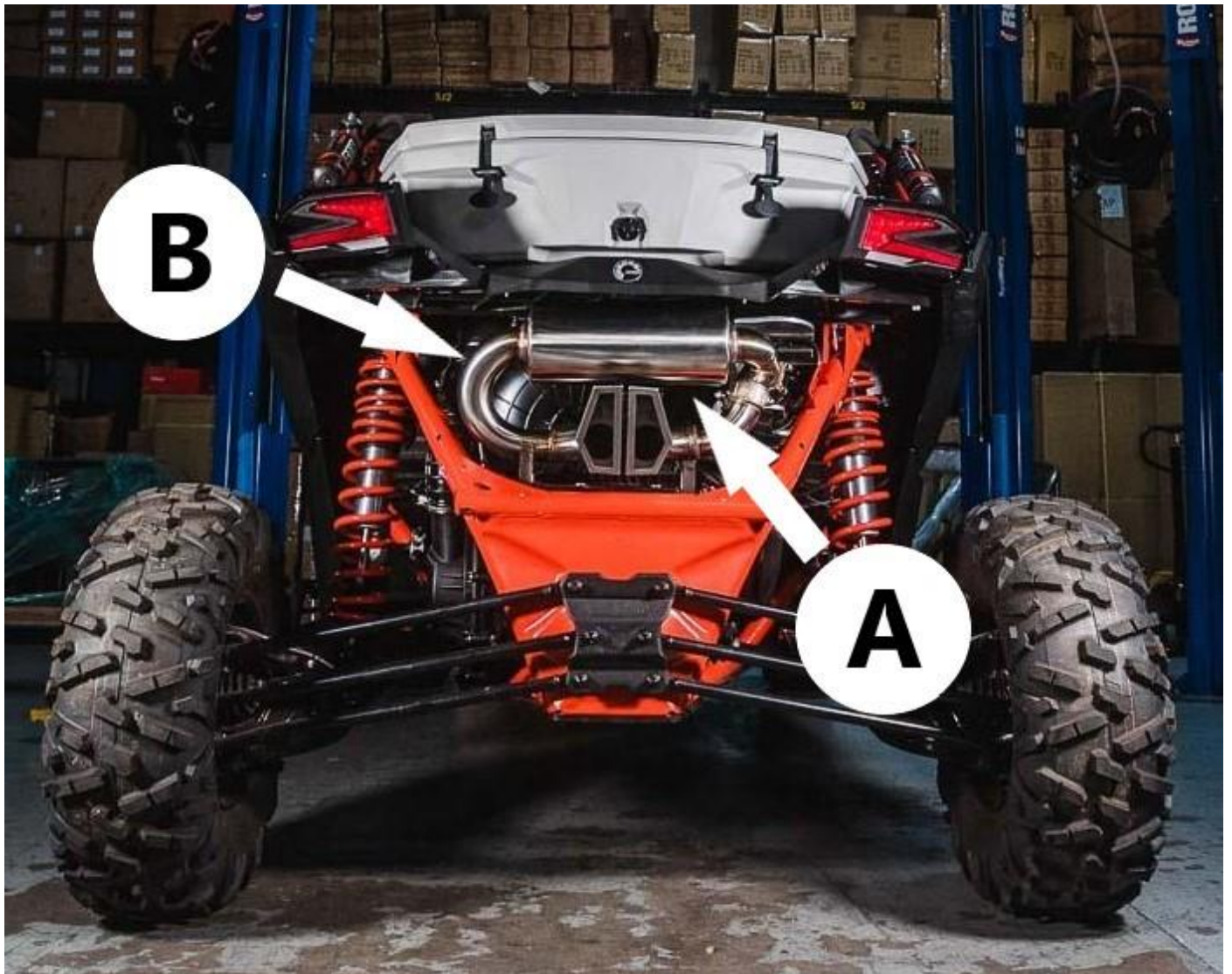

(A) manifold absolute pressure sensor

(B) turbo boost pressure sensor

3 Installation

Step 3 - Connection to turbo boost pressure sensor



- To begin, locate the turbo boost pressure sensor in your engine bay.

Setup illustration

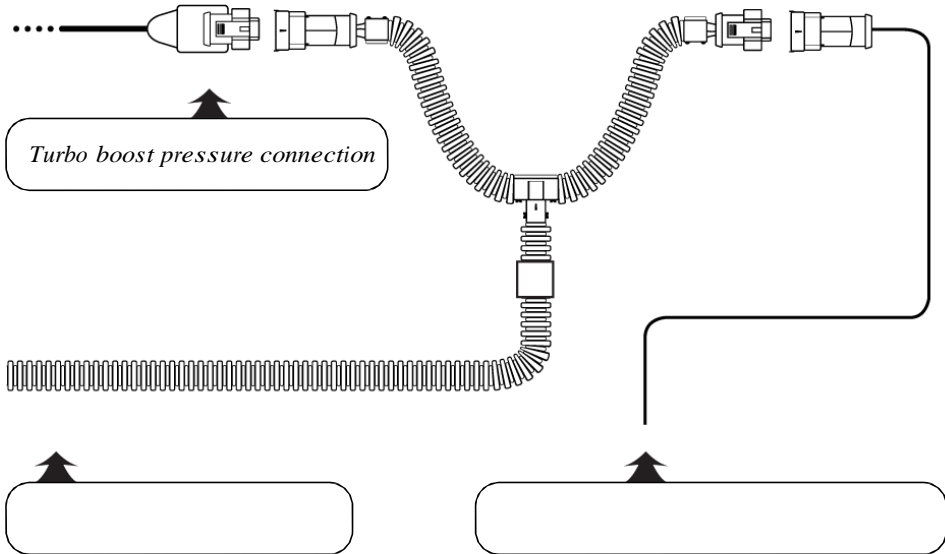

3 Installation

- Disconnect the plug from turbo boost pressure sensor.



If you experience difficulties disconnecting the turbo boost pressure sensor, see **Detaching the Connector Correctly** (separate document) for assistance.

- Now connect the end of the wiring harness marked "B" to the disconnected connector and the other end to the sensor.



Make sure that the plug's locking clip engages again. You should hear a sharp CLICK.

3 Installation

Step 4 - Connection to manifold absolute pressure sensor

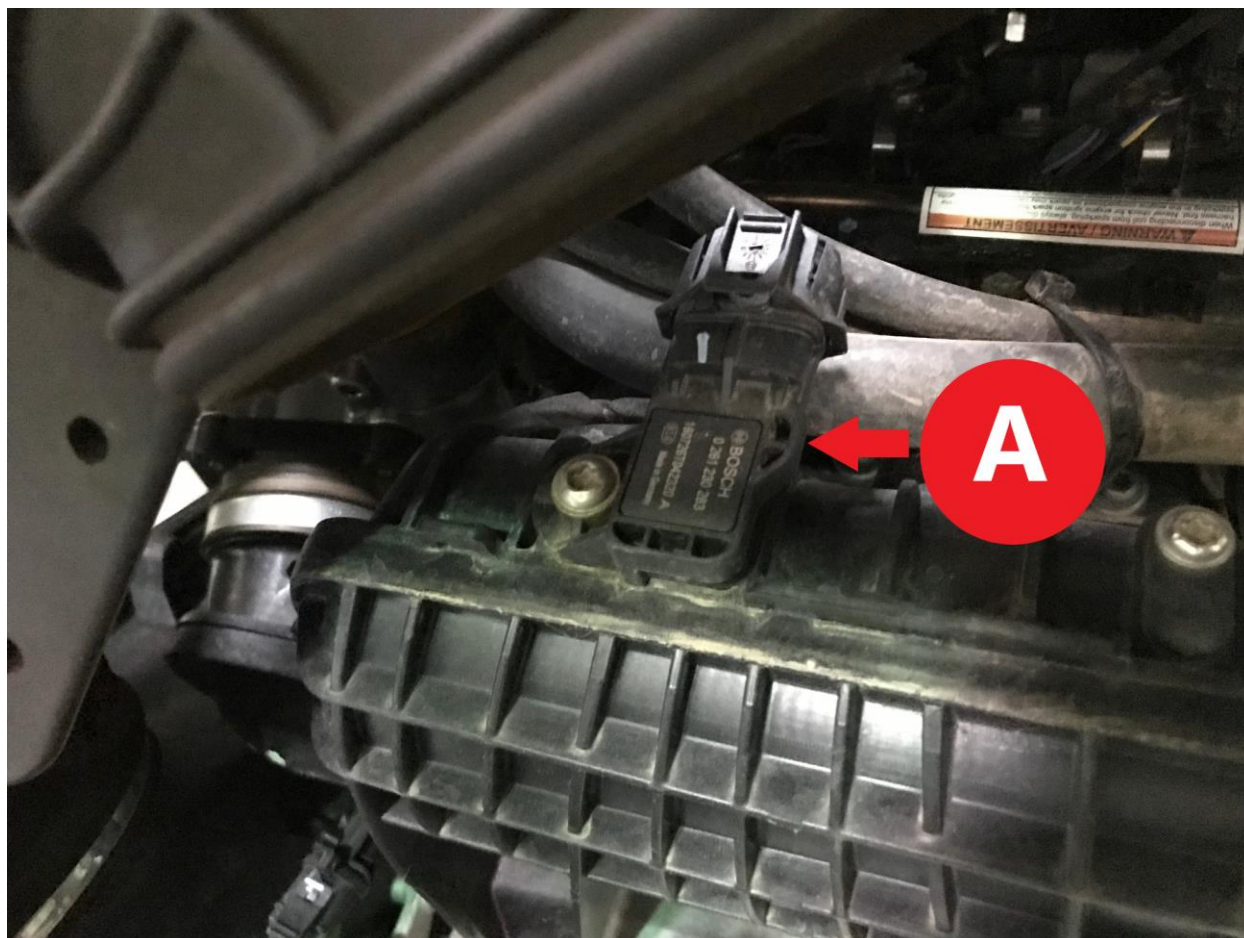

- To begin, locate the connection to the manifold absolute pressure sensor in your engine bay.

Setup illustration

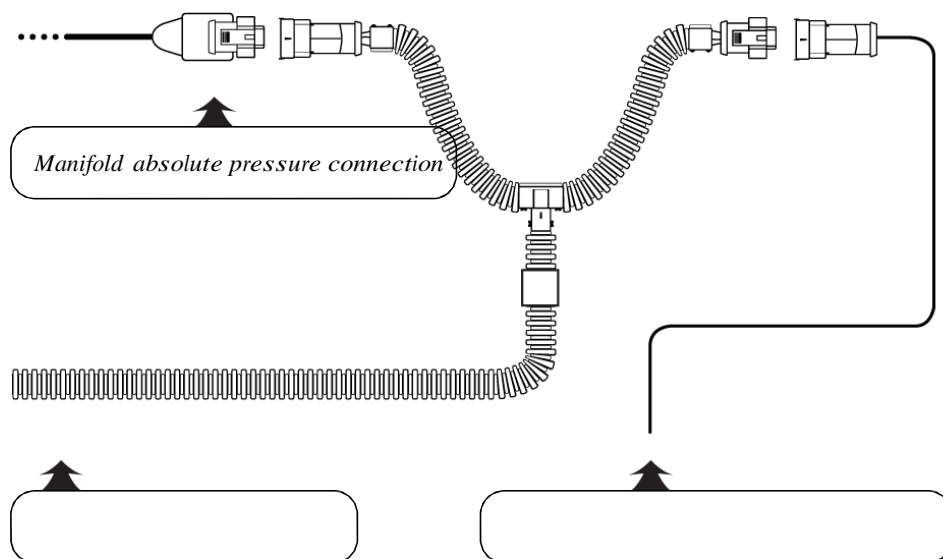

3 Installation

- Disconnect the plug from the manifold absolute pressure sensor.



If you experience difficulties disconnecting the manifold absolute pressure sensor, see **Detaching the Connector Correctly** (separate document) for assistance.

- Now connect the end of the wiring harness marked "A" to the disconnected connector and the other end to the sensor.



Make sure that the plug's locking clip engages again. You should hear a sharp CLICK.

Step 7 - Connecting and first function test

- 1. Disconnect the deactivation plug from the wiring harness**
- 2. Connect V2 Tuning Box to wiring harness**

- If the Digital User Interface lit up as soon as it was connected, this means that there was still power in the system during the installation.

- In some cases, this can lead to an error message during the first function test. Please refer to **Trouble Shooting** for a solution.

- 3. Carry out function test**

- Position the tuning module and the wiring harness safely in the engine bay.
- Switch the ignition on. **DO NOT** start the engine.
- Check for the following:

Control lights on the dashboard light up and go out as normal

The Power ON light on the Digital User Interface of your tuning module lights up (see **Overview**)

- If all the above happens, you can start the engine. It should start as normal and should react to the throttle when idling.
- Switch off the engine and ignition.

! If your car will not start as normal, please refer to **Trouble Shooting** for hints and tips !

3 Installation

Step 8 - Fixing the tuning module and wiring harness

- Before fixing the tuning module in place in the engine bay, ensure that the wiring harness can also be routed and fixed securely without putting it under excessive tension.
- Use the 360° fixing clips included to fix the tuning module and thread the cable ties through the fixing clips to hold the wiring harness in place.

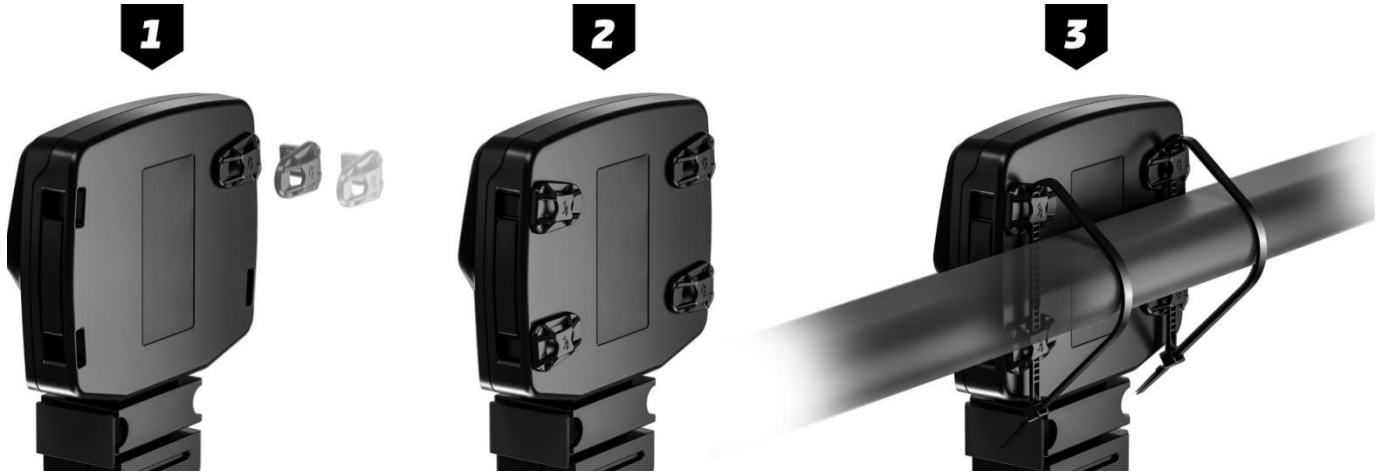

- If you need to remove the tuning module at a later date, you can simply release the clips and do not have to cut any cable ties.
- Route the cable along a suitable path (for example, along existing wiring harness) and then fasten it.

,&

- When selecting a fastening point make sure that the tuning module is protected from exposure to water, heat and vibrations.
- Do not wrap the tuning module in an airtight bag as this can lead to a built up of condensation.
- Do not route the cable in areas in your vehicle that become overly hot during operation (e.g. the exhaust system, turbocharger, etc.).
- Do not route the cable along movable parts.
- Never fasten the cable onto hoses (e.g. a brake hose) as this could result in abrasion.

- The installation process is now complete and your tuning module is ready for use.
- Take your car for a test drive.

3 Installation

For Tuning Box adjustment / fine tuning Please review the “Adjusting Tuning Box” link found here - <https://www.vrtuned.com/blog/wp-content/uploads/vrtuned-box-settings.pdf>

For trouble shooting please please review the “Trouble Shooting” link found here - <https://www.vrtuned.com/blog/wp-content/uploads/vrtuned-trouble-shooting.pdf>