



Part number SES9003TT
2016-2017 Ford Focus RS
2.3L turbo 4cyl. AWD

- 1- 3 piece cat back exhaust
- 1- 76mm band clamp (#4015)
- 1- 3.00 gasket (#17060)
- 2- M10 hex bolt (#6038)
- 2- M10 hex nut (#6069)
- 1- Exhaust valve by-pass module(#2002)
- 1- Black zip-tie (#8014)

Congratulations! You have just purchased the best engineered, dyno-proven exhaust system available.

Please check the contents of this box immediately.

Report any defective or missing parts to the Authorized Injen Technology dealer you purchased this product from. Before installing any parts of this system, please read the instructions thoroughly. If you have any questions regarding installation please contact the dealer you purchased this product from.

Installation DOES require some mechanical skills. A qualified mechanic is always recommended.

*Do not attempt to install the intake system while the engine is hot. The installation may require removal of radiator fluid line that may be hot.

Injen Technology offers a limited lifetime warranty to the original purchaser against defects in materials and workmanship. Warranty claims must be handled through the dealer from which the item was purchased.

Injen Technology 244 Pioneer Place Pomona, CA 91768 USA

Please check the contents of this box immediately.
Parts and accessories are available on line at "Injenonline.com"



Figure 1

NOTE: All Injen exhaust systems are engineered to comply with the 95dB noise limit law specified by the California Highway Patrol and the Society of Automotive Engineers - Except ones that are designated for "Off-Road Use only".

Every Injen exhaust system is individually designed for a specific application and complies with the requirements of Sections 27150, 27151 & 27200 of the California Vehicle Code and Title 13 of the California code of Regulations, Section 10361, which establishes a noise limit of 95dB for passenger cars.

The age of your exhaust system along with certain engine modifications, such as headers, intake, etc., may also affect its current noise level output.

Please check with your local and state law enforcement agencies for exact regulation requirements.

Warning: The factory/OEM exhaust system has to be cut in order to be removed. Injen recommends that this exhaust system be installed by a professional.

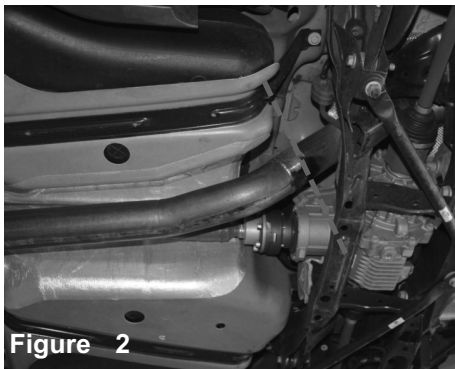

Figure 2

Locate this spot on the factory exhaust, this is a great spot to cut and also, if needed to re-install, you can have welded to have stock exhaust installed.

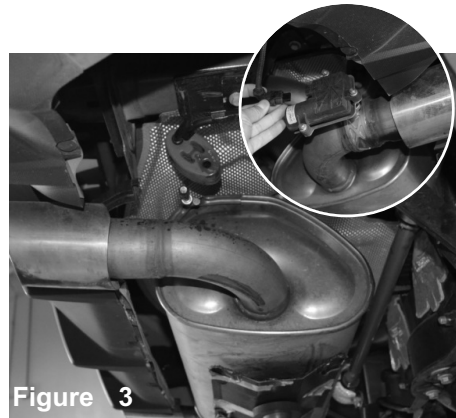

Figure 3

Lubricate all hanger isolators and pull back. Disconnect the Exhaust Valve sensor harness.



Figure 4

Position the rear muffler section and remove through the frame.

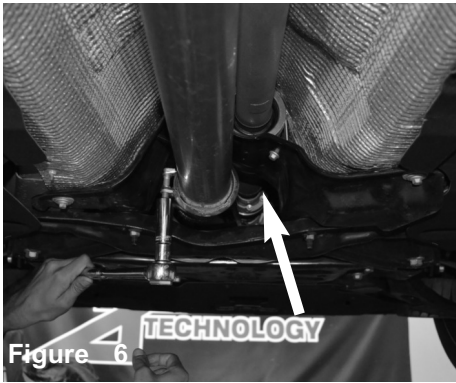

Figure 6
Using 15mm socket and ratchet, loosen the band clamp and pull back exhaust. Loosen and remove the hangar isolator.



Figure 7
Remove the complete exhaust system out of the vehicle.

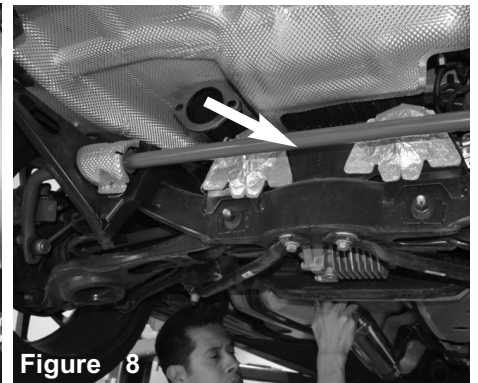

Figure 8
Install the mid pipe and place into vehicle. position hangar to the rubber isolator.

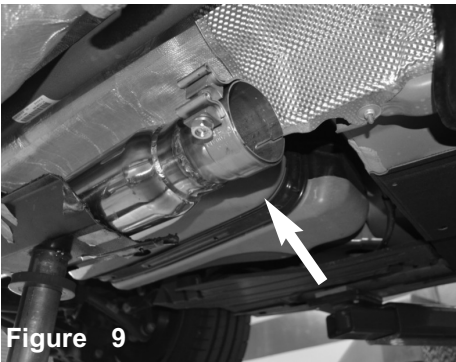

Figure 9
Install the provided 76mm band clamp to the mid pipe. **DO NOT TIGHTEN!**

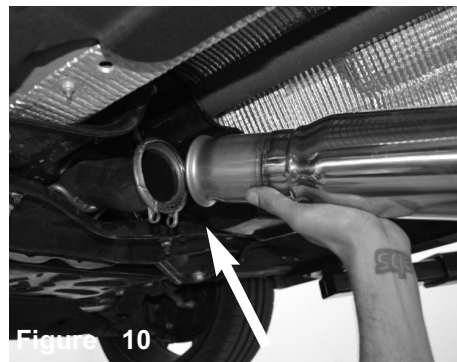

Figure 10
Install the front pipe to the vehicle and position the flange to the v-band clamp position for it to seat properly. Install the hangar into the rubber isolator.



Figure 11
Secure the front pipe and mid pipe using band clamp, snug fit using 17mm socket and or wrench. **DO NOT TIGHTEN!**

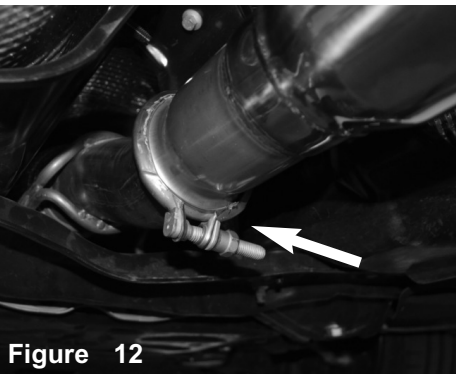

Figure 12
Position exhaust and rotate if necessary.

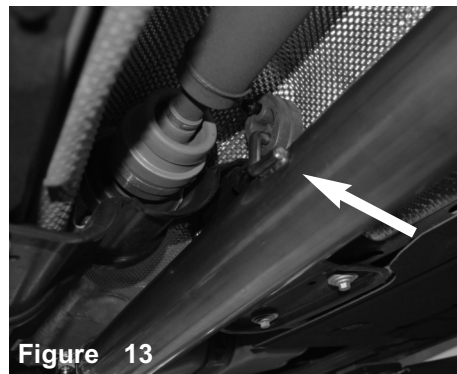

Figure 13
Verify the metal hangar has clearance and does not come close to the drive shaft.

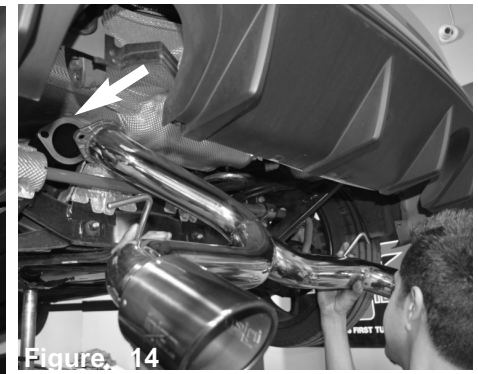

Figure 14
Install the rear piece into the vehicle. Position the flange. Position the hangars to the rubber isolator.

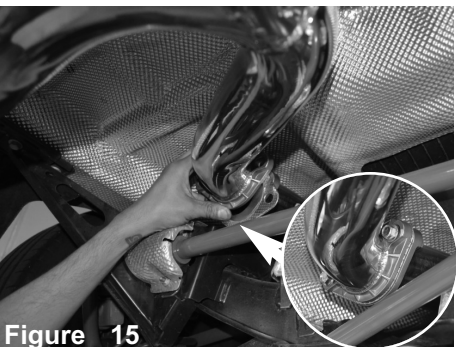

Figure 15
Secure flanges using provided gasket and M8 bolts and nuts. **DO NOT TIGHTEN! Now position for the best fit.** This may require to loosen and retighten other flanges. Tighten all flanges using 14mm socket and wrench. Secure and tighten band clamp. Push exhaust forward for exhaust to fit properly.

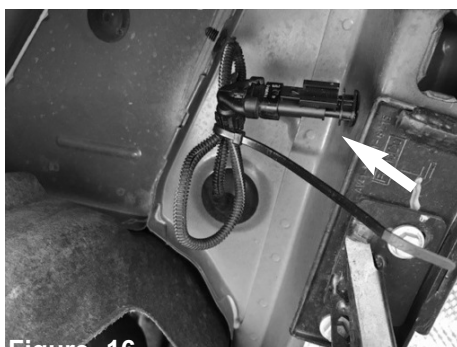

Figure 16
Now with provided Exhaust Valve by-pass module, connect to the harness from step 3. Tighten up and bundle the harness using provided zip-tie. **Note: Make sure the Exhaust valve by-pass module is installed or vehicle will not be able to select Drive modes.**



Figure 17
Your installation is now complete. Check for clearance and position for best possible fit. Re-install the mid-frame support brace. Make sure there is clearance and the exhaust is not touching.