

# MB1221 - JT Gladiator Diesel Skid System

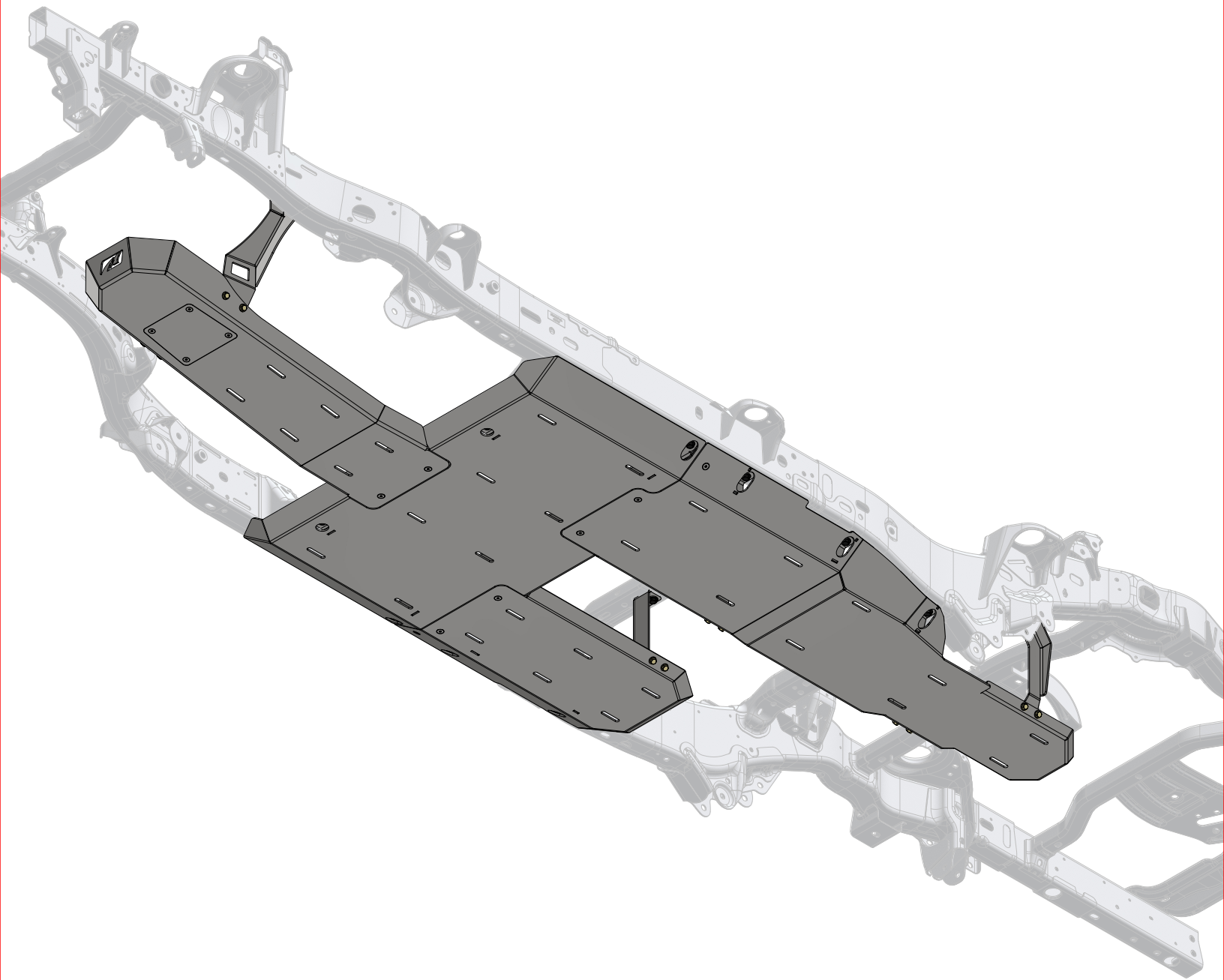

## ASSEMBLY INSTRUCTIONS

**MB1221-Shipping JT Gladiator Diesel Skid System**

**CONTENTS**

**Transmission Skid**

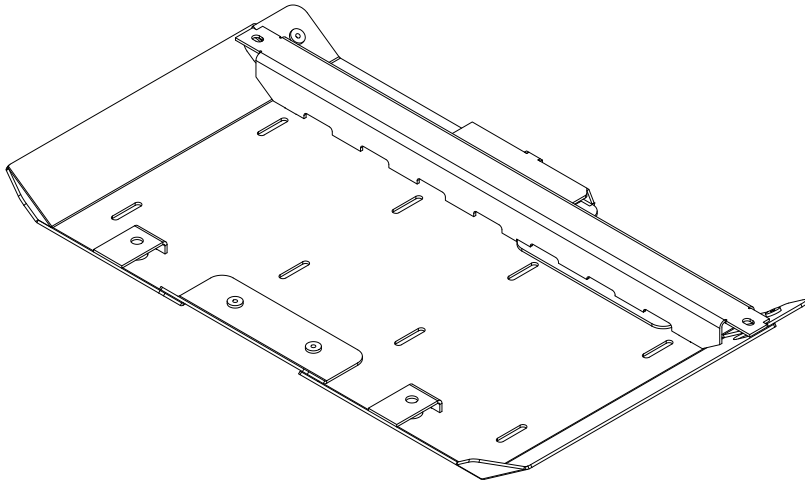

MB1221-A - Weldment  
Qty 1

**Engine Skid**

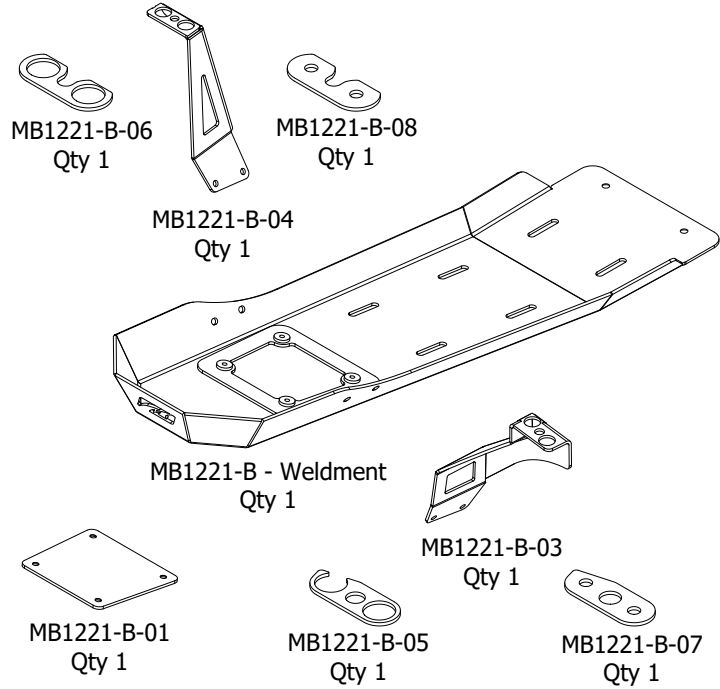

**Exhaust Skid**

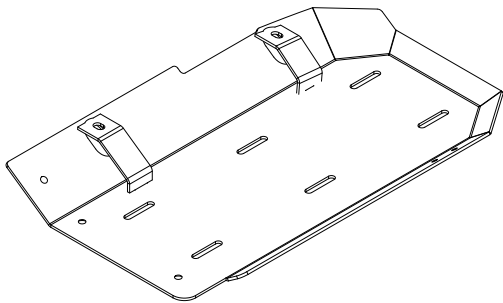

MB1221-D - Weldment  
Qty 1

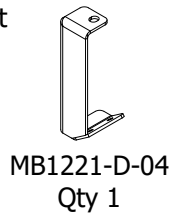

**Gas Tank Skid**

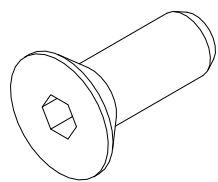
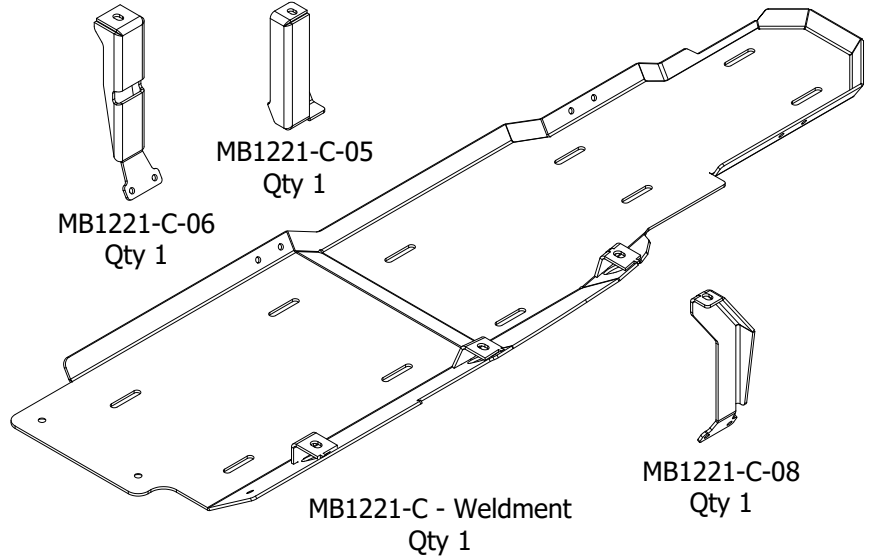

3/8"-16 x 1" Socket Flat Head Screw  
Qty 14  
(Includes 2 Spare)

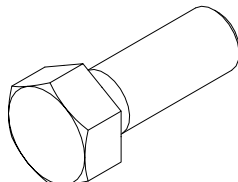

3/8"-16 x 1" Hex Bolt  
Qty 14  
(Includes 2 Spare)

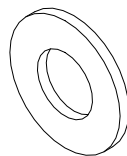

3/8" Flat Washer  
Qty 26  
(Includes 2 Spare)

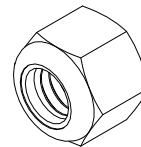

3/8"-16 Nylon Insert Hex Locknut  
Qty 14  
(Includes 2 Spare)

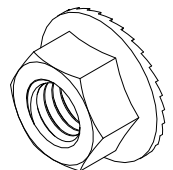

M10x1.5 Serrated Flange Nut  
Qty 4

# MB1221 - Assembly Instructions Diesel Gladiator Skid Plate System

## ASSEMBLY - PREP

1. We recommend to test fit all Motobilt parts on the vehicle **BEFORE** painting or powder coating them.
2. Remove the factory transmission & transfer case guards, as shown below. NOTE: Save all factory fasteners, as many will be reused to install your new Motobilt Skid System.

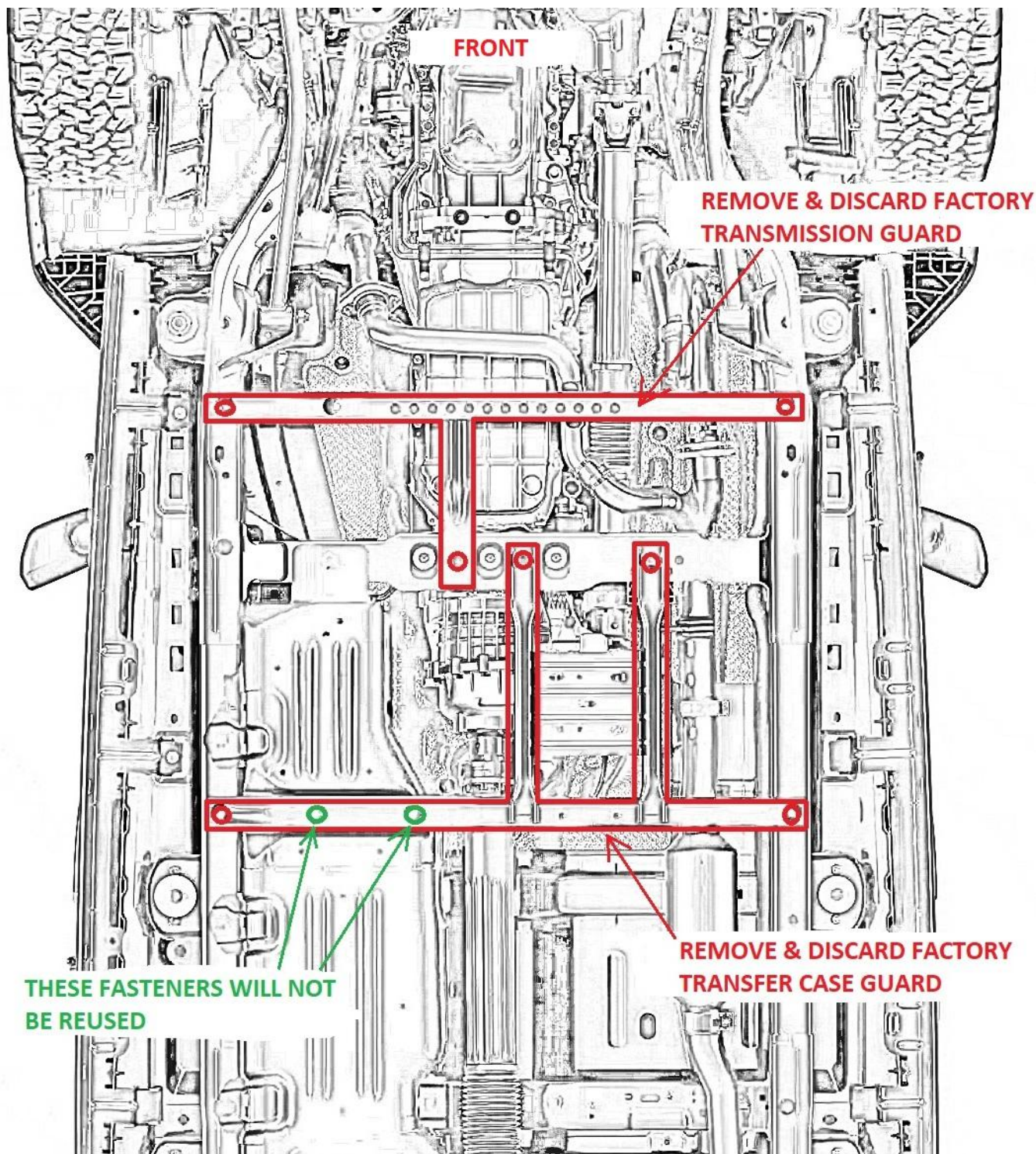

This underside view shows a Jeep JT with a different engine and exhaust system. This product will only work with the 3.0 EcoDiesel engine and exhaust. The guards shown to be removed are common with all models of Jeep JT.



**MB1221 - Assembly Instructions Diesel Gladiator Skid Plate System**

**ASSEMBLY - STEP 01**

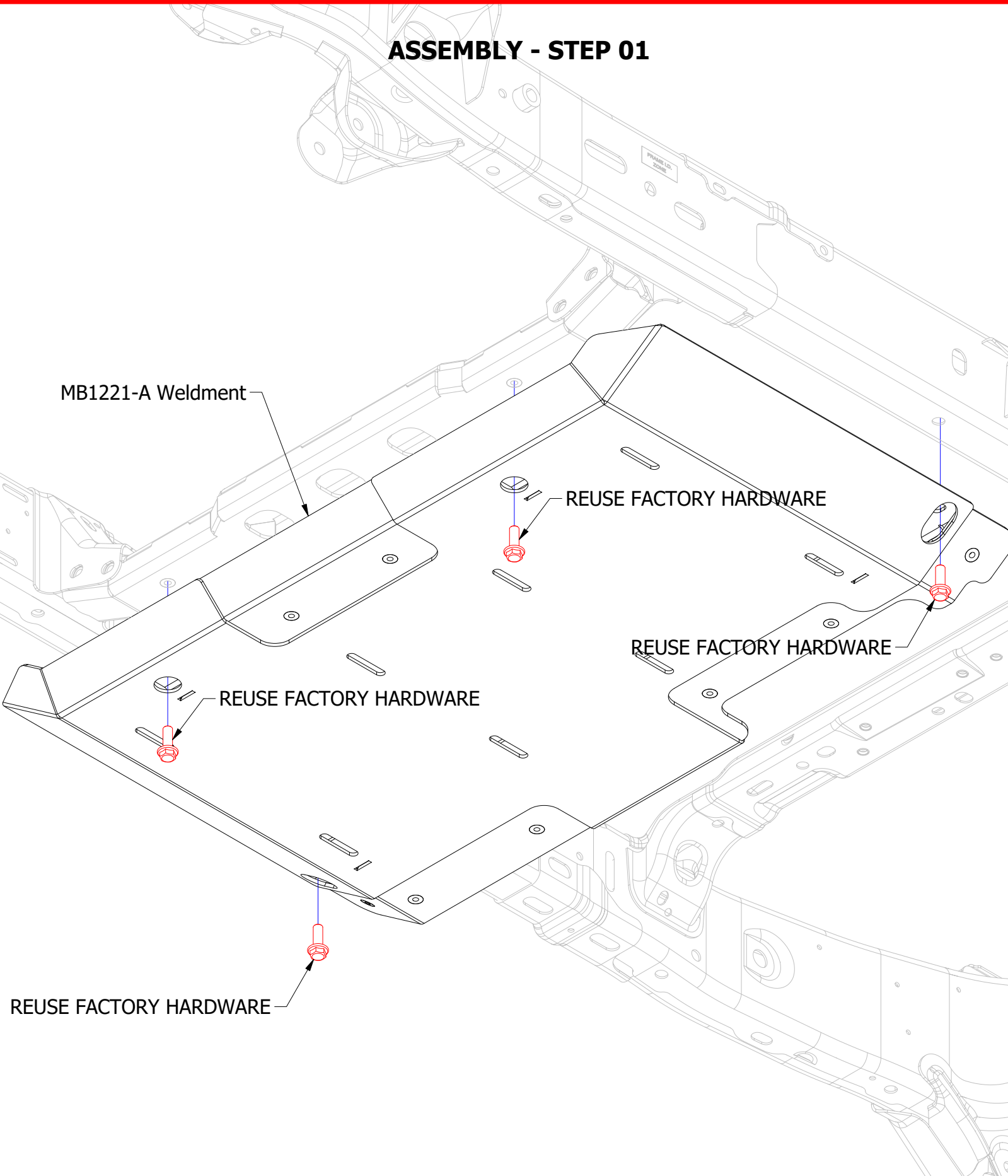

**MB1221 - Assembly Instructions Diesel Gladiator Skid Plate System**

**ASSEMBLY - STEP 02**

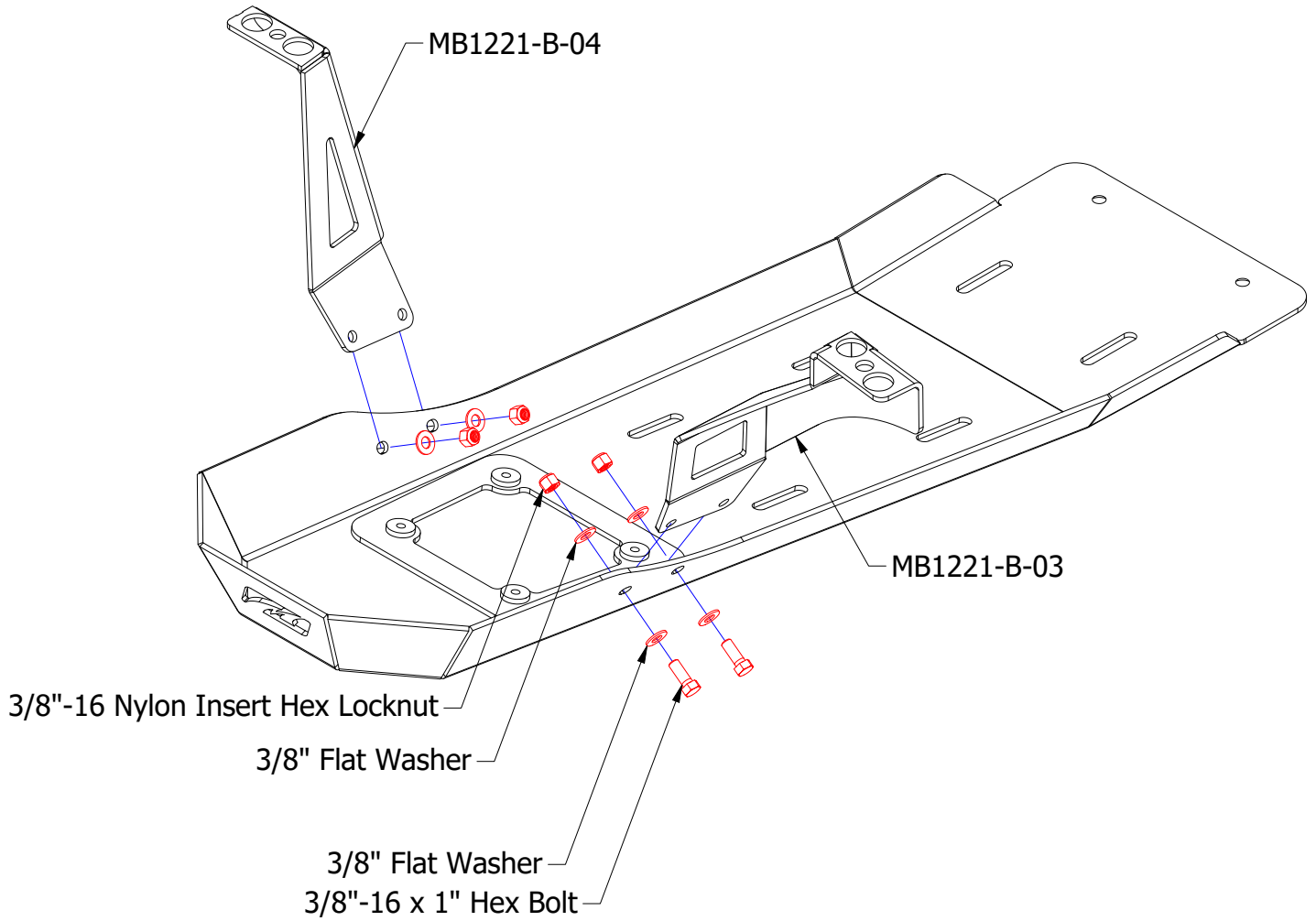

**INSTALL BRACKETS, DO NOT TIGHTEN BOLTS**

**MB1221 - Assembly Instructions Diesel Gladiator Skid Plate System**

**ASSEMBLY - STEP 03**

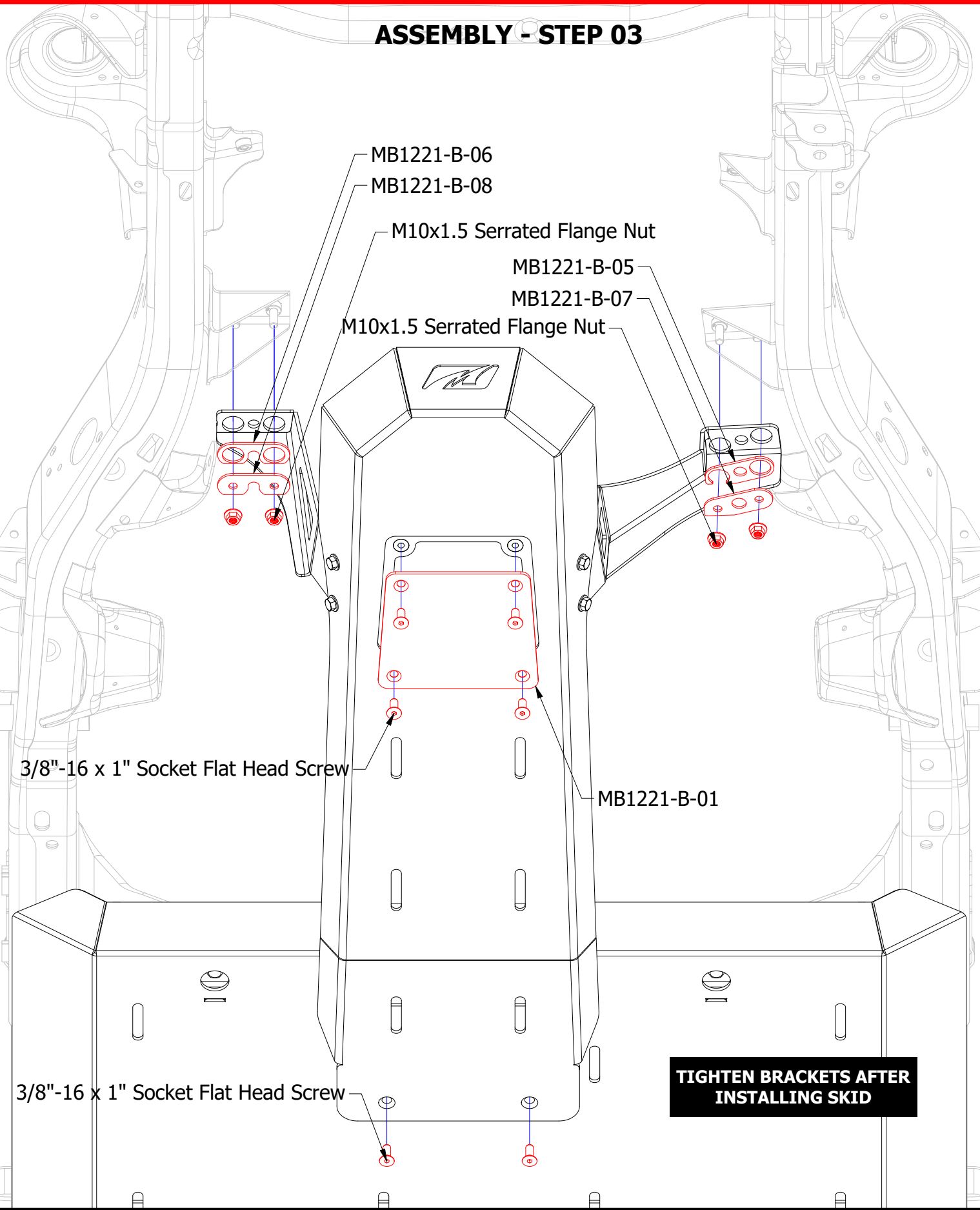

MB1221-B-06

MB1221-B-08

M10x1.5 Serrated Flange Nut

MB1221-B-05

MB1221-B-07

M10x1.5 Serrated Flange Nut

3/8"-16 x 1" Socket Flat Head Screw

MB1221-B-01

3/8"-16 x 1" Socket Flat Head Screw

**TIGHTEN BRACKETS AFTER  
INSTALLING SKID**

**MB1221 - Assembly Instructions Diesel Gladiator Skid Plate System**

**ASSEMBLY - STEP 04**

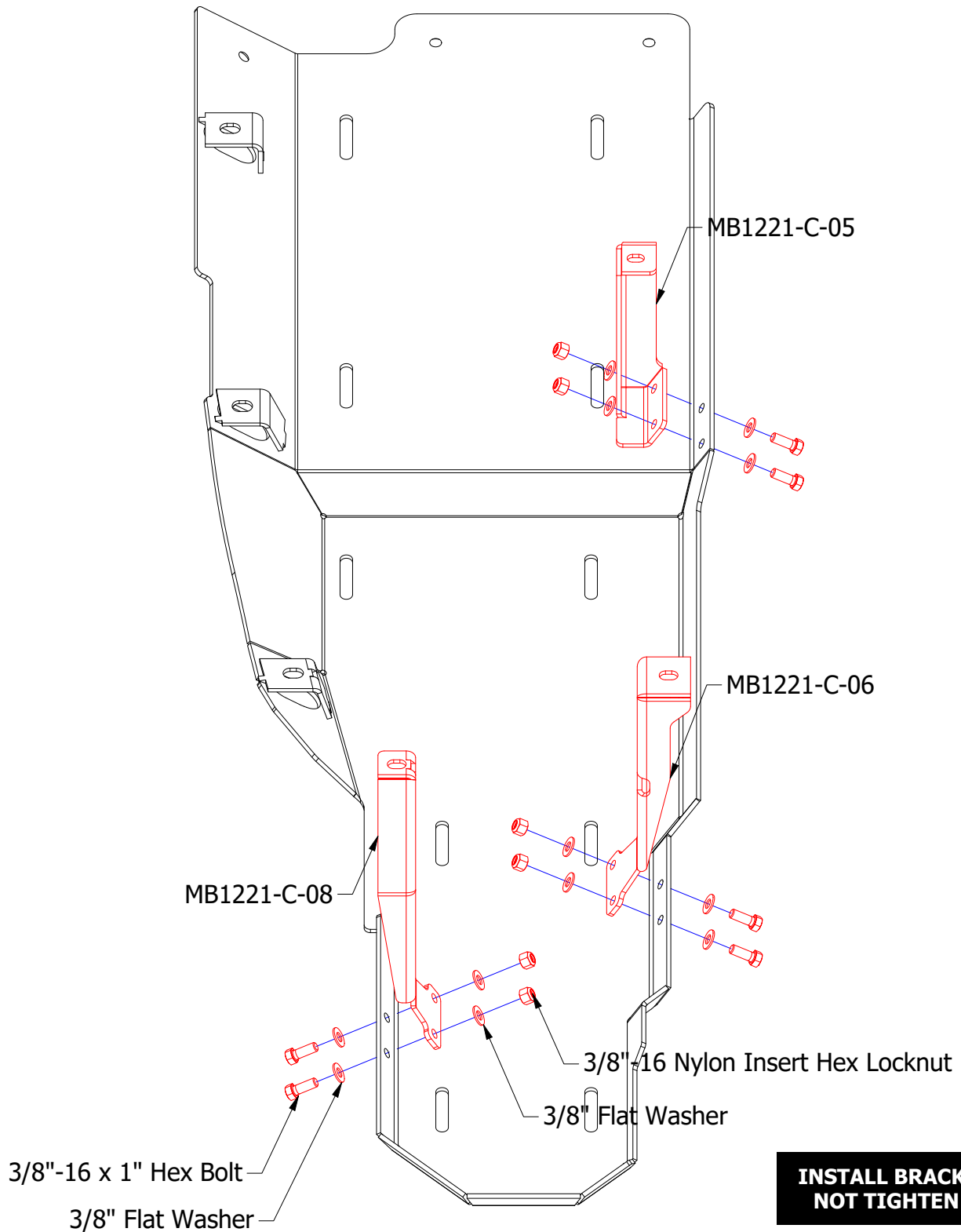

**MB1221 - Assembly Instructions Diesel Gladiator Skid Plate System**

**ASSEMBLY - STEP 05**

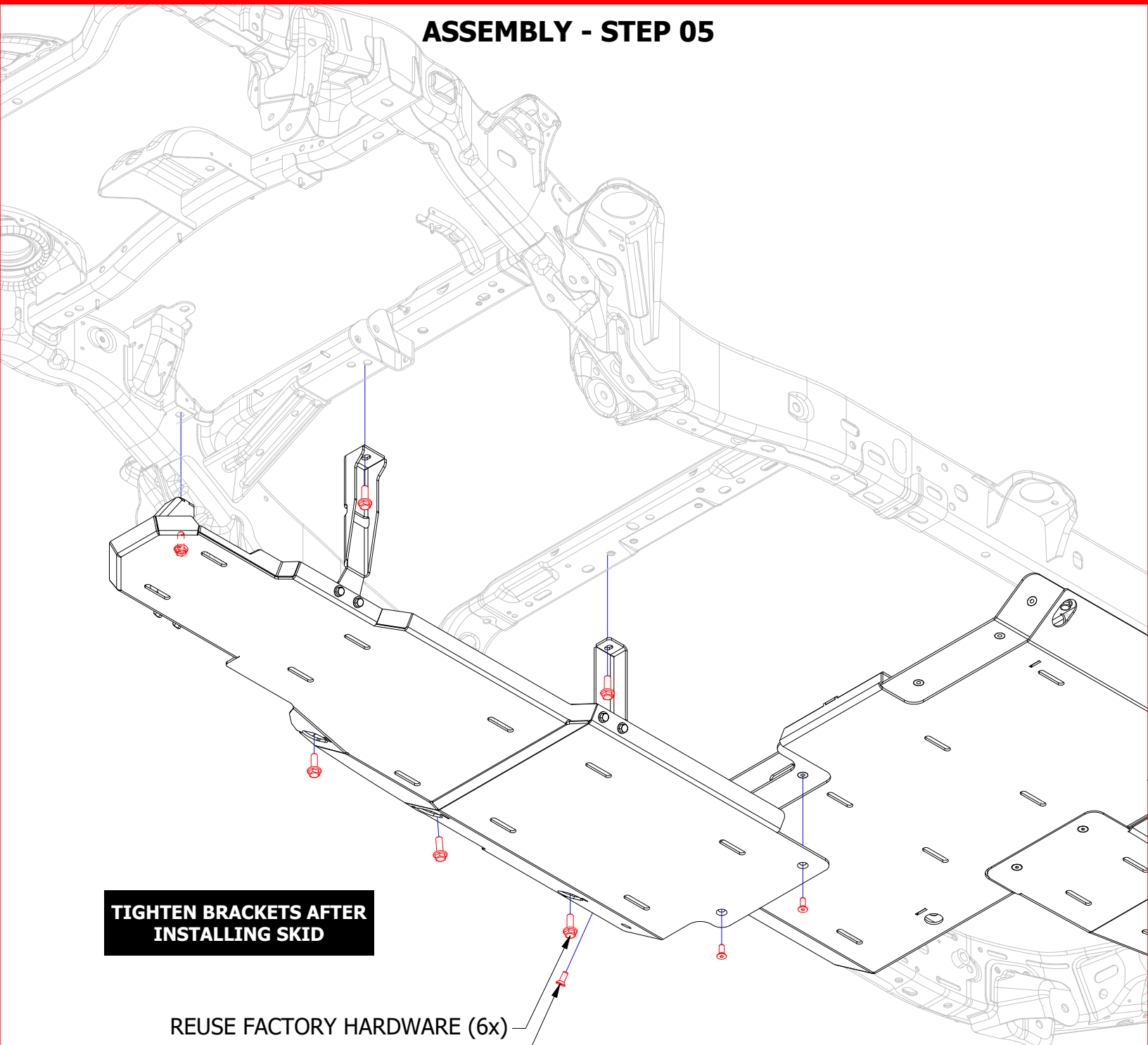

**TIGHTEN BRACKETS AFTER  
INSTALLING SKID**

REUSE FACTORY HARDWARE (6x)

3/8"-16 x 1" Socket Flat Head Screw (3x)



**MB1221 - Assembly Instructions Diesel Gladiator Skid Plate System**

**ASSEMBLY - STEP 06**

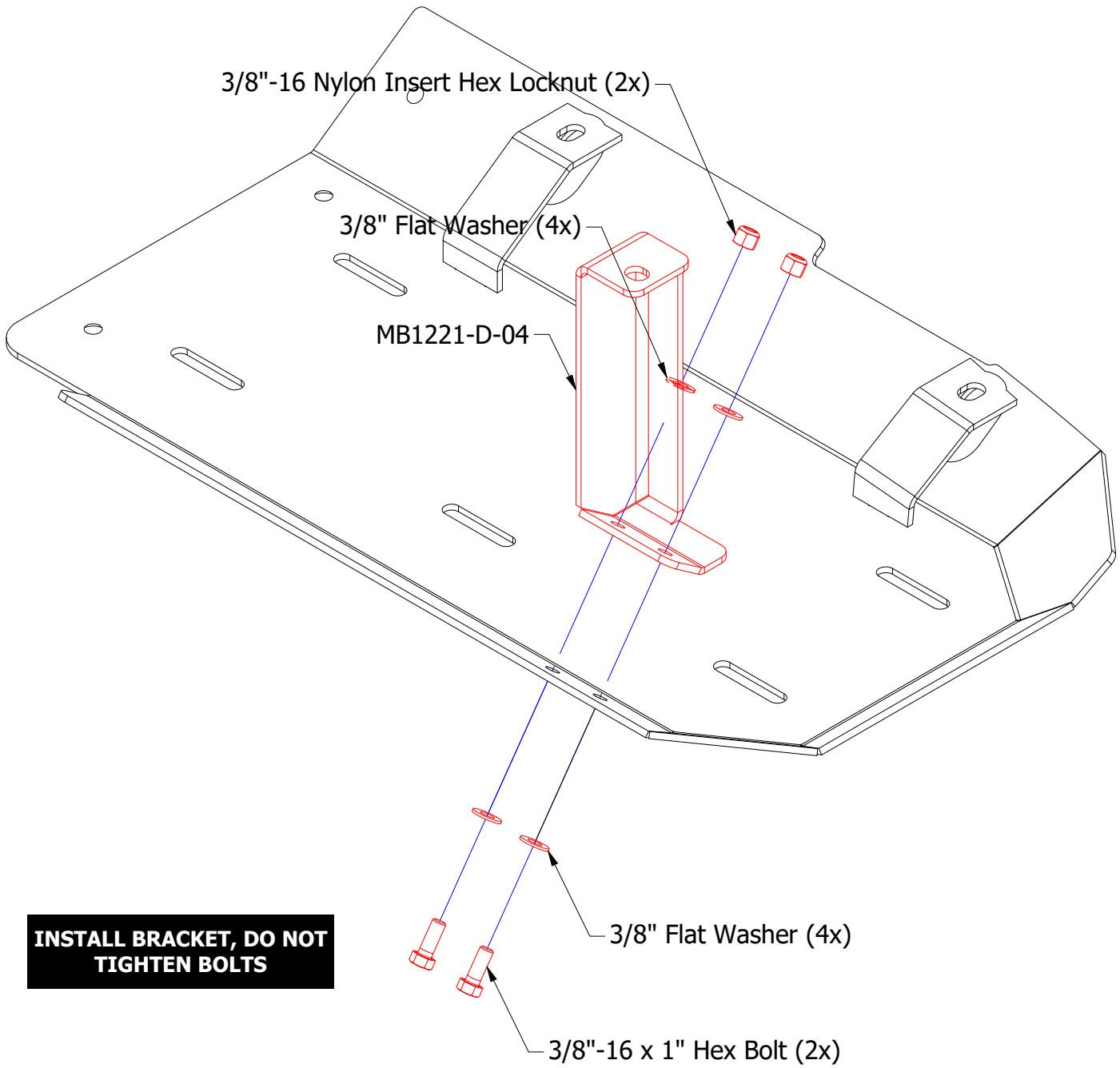

**MB1221 - Assembly Instructions Diesel Gladiator Skid Plate System**

**ASSEMBLY - STEP 07**

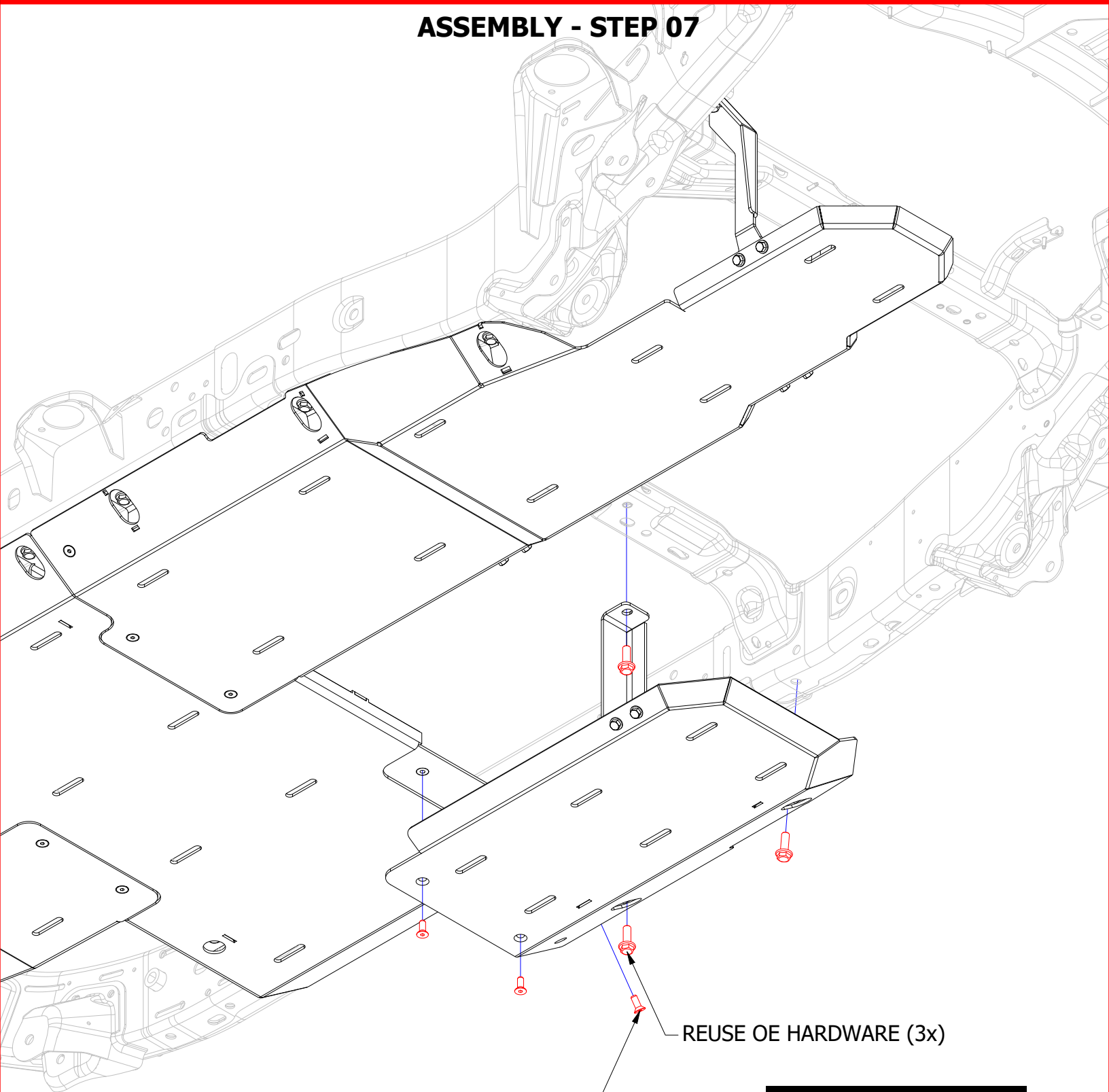

3/8"-16 x 1" Socket Flat Head Screw (3x)

REUSE OE HARDWARE (3x)

**TIGHTEN BRACKETS AFTER  
INSTALLING SKID**