

WARNING
HARDWARE THREAD GALLING

We provide Fasteners in Stainless Steel to ensure a long life span. Although Stainless Steel has many benefits like extreme corrosion resistance, threads can be sensitive to Nylon Lock Nuts. We recommend installing hardware with an Anti-Seize thread lubricant to prevent thread galling. Slowing down speed of install and keeping bolts stationary while tightening nuts are common practices to prevent thread galling.

INSTALLATION GUIDE:
VW MK7 GOLF TSI/TDI - FRONT SPLITTER (STREET EDITION)

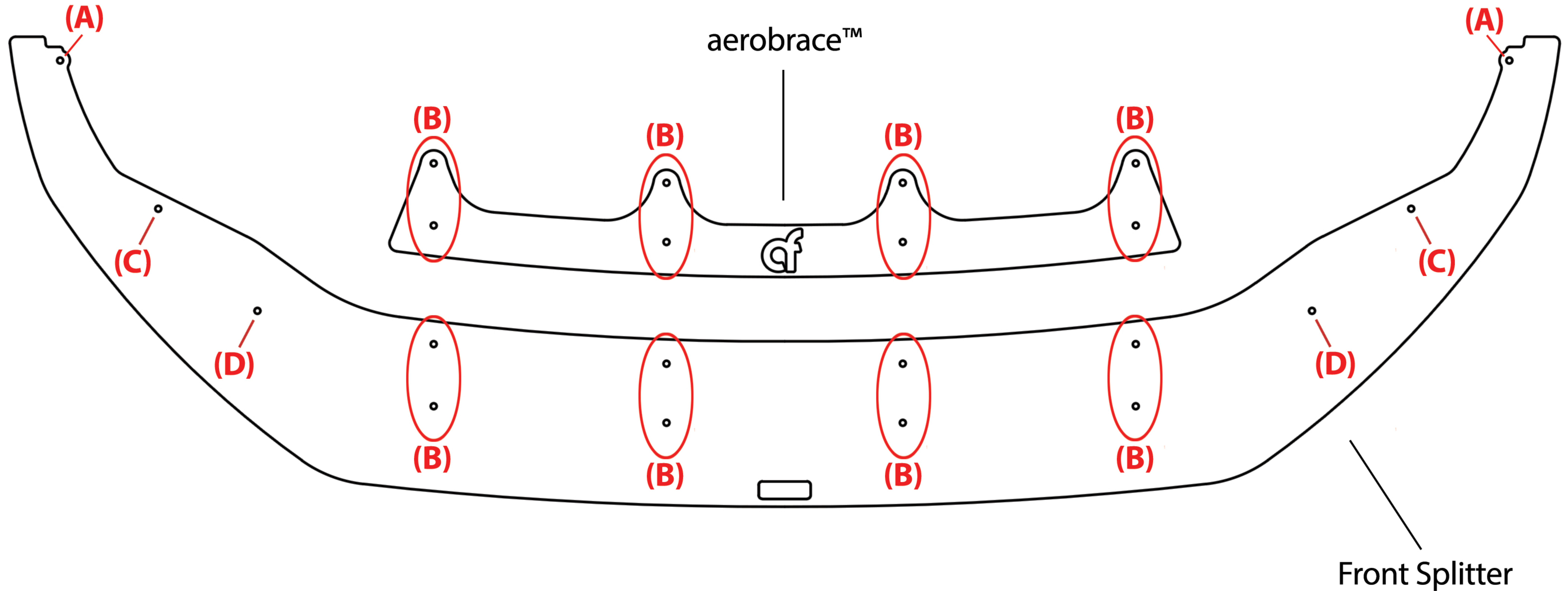

NOTES:
1. Labeled Hardware corresponds to labeled holes shown in diagram.

INSTALLATION GUIDE:
VW MK7 GOLF TSI/TDI - FRONT SPLITTER (STREET EDITION)

ALIGNMENT HARDWARE (A)

QTY	DESCRIPTION
2	M6 X 30MM BOLT
4	M6 X 18MM OD WASHER
2	M6 NYLON LOCKNUT

HARDWARE (B)

QTY	DESCRIPTION
8	M6 X 60MM BOLT
24	FENDER WASHER
8	¾" OD X 1" LG SPACER
8	½" OD X ¼" LG SPACER
8	M6 NYLON LOCKNUT

HARDWARE (C)

QTY	DESCRIPTION
2	M6 X 30MM BOLT
4	FENDER WASHER
2	½" OD X ¼" LG SPACER
2	M6 NYLON LOCKNUT

HARDWARE (D)

QTY	DESCRIPTION
2	M6 X 40MM BOLT
4	FENDER WASHER
2	¾" OD X ½" LG SPACER
2	M6 NYLON LOCKNUT

NOTES:
 1. CONFIRM NO HARDWARE IS MISSING BEFORE INSTALL.

MAKE THE FOLLOWING TOOLS READY FOR USE

- Drill
- 1/4" Drill Bit
- 10mm Wrench
- 4mm Hex Wrench
- T-25 Torx
- Anti-Seize (recommended)

aerofabb, LLC is not responsible for damage to you or your vehicle while following this Install Guide and/or installing aerofabb products. Professional install is recommended. aerofabb also recommends installing hardware with **Anti-Seize (thread lubricant)** and Hand Tools to prevent thread galling. Please read this install guide in its entirety prior to installing this product.

1. Using a **T-25 Torx**, remove Front Bumper and place upside down on a non-abrasive surface.
2. Identify pre-existing holes **(A)** on underside of Front Bumper (closest to wheels).



INSTALLATION GUIDE:
VW MK7 GOLF TSI/TDI - FRONT SPLITTER (STREET EDITION)

3. Using a **1/4" Drill Bit**, drill directly through pre-existing Bumper holes **(A)** widening them to 1/4".

4. Place the aerofabb Front Splitter on underside of Bumper. Using a **4mm Hex** and **10mm Wrench**, install **ALIGNMENT HARDWARE (A)** passing through both Splitter and Bumper holes **(A)**. Tighten Hardware.

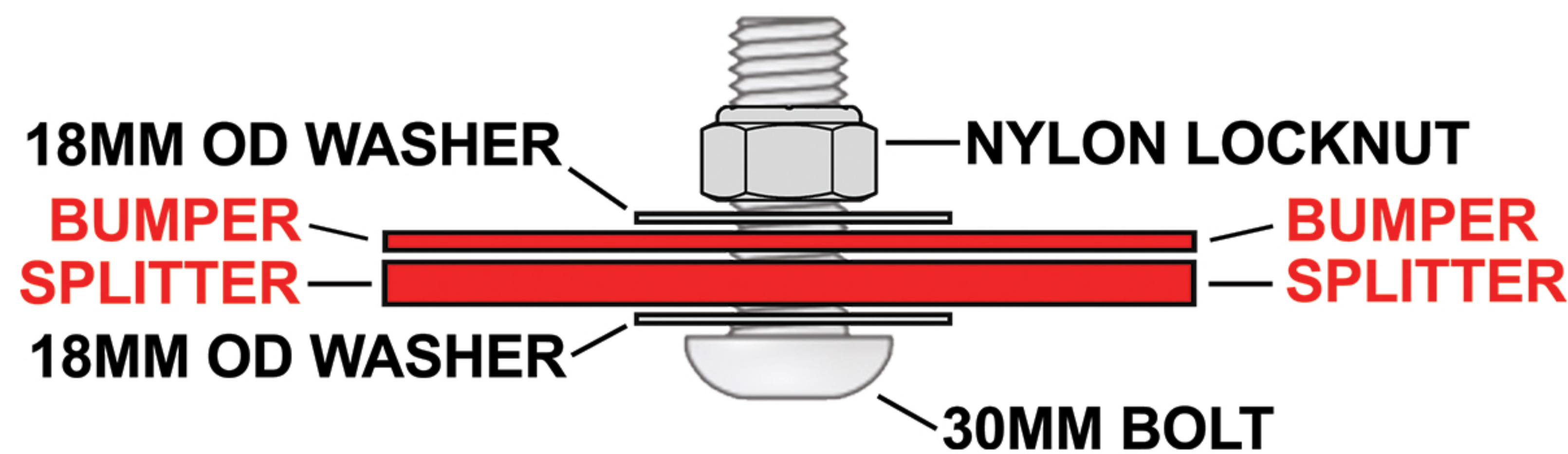

5. With **ALIGNMENT HARDWARE (A)** installed and Splitter secured on both ends, drill through the 12 remaining Splitter holes **(B)**, **(C)**, and **(D)**.

NOTES:

1. Run Bit through multiple passes to ensure holes are clear of debris.
2. Check bolt threads for plastic debris before threading locknuts.
3. Do not overtighten Hardware.

6. Pull only the following fasteners from **HARDWARE (B)** and set aside the remaining for later use in Step 11.

QTY	DESCRIPTION
8	M6 X 60MM BOLT
8	FENDER WASHER
8	3/4" OD X 1" LG SPACER
8	M6 NYLON LOCKNUT

7. Use above quantity to Install **HARDWARE (B)** through Splitter holes **(B)**. Only tighten locknut by hand.

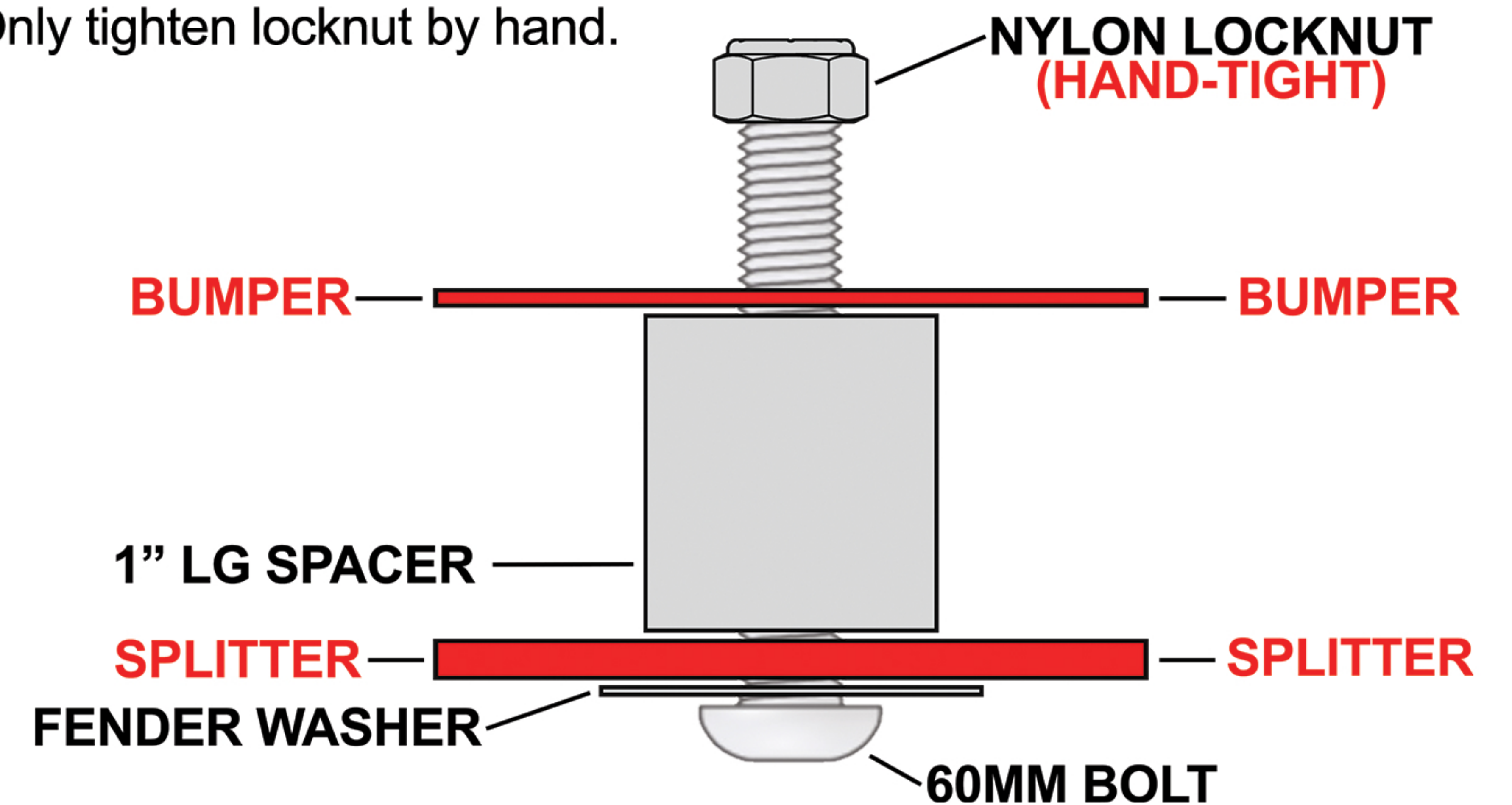

8. Install **HARDWARE (C)** through Splitter holes **(C)** and tighten.

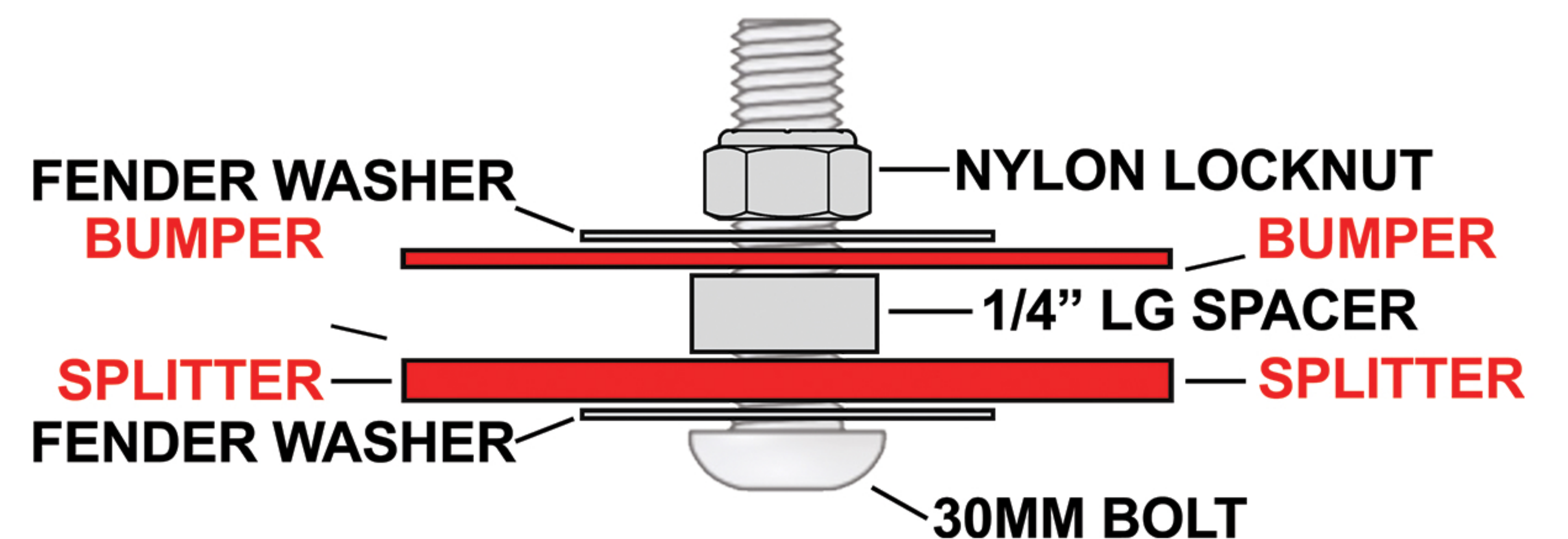

INSTALLATION GUIDE:

VW MK7 GOLF TSI/TDI - FRONT SPLITTER (STREET EDITION)

9. Install **HARDWARE (D)** through remaining Splitter holes **(D)** and tighten.

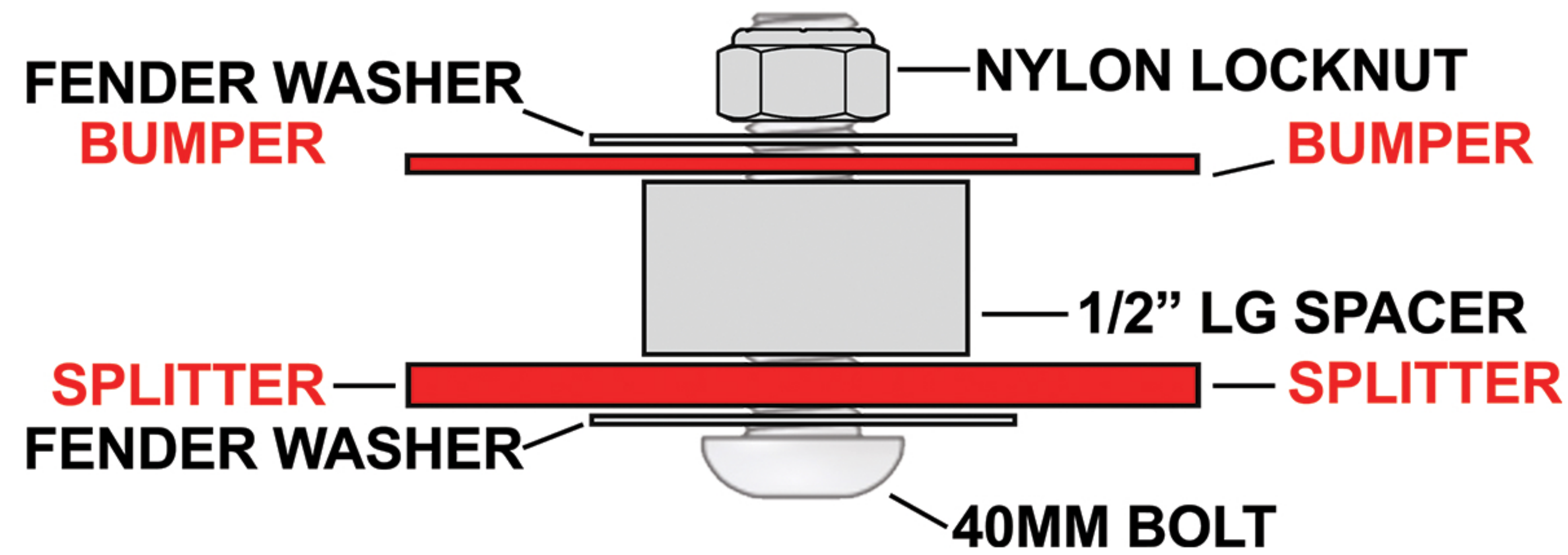

10. Turn the Bumper right-side up and remove all locknuts from holes **(B)**.

11. Install the aerobraces™ with remaining fasteners from **HARDWARE (B)**.

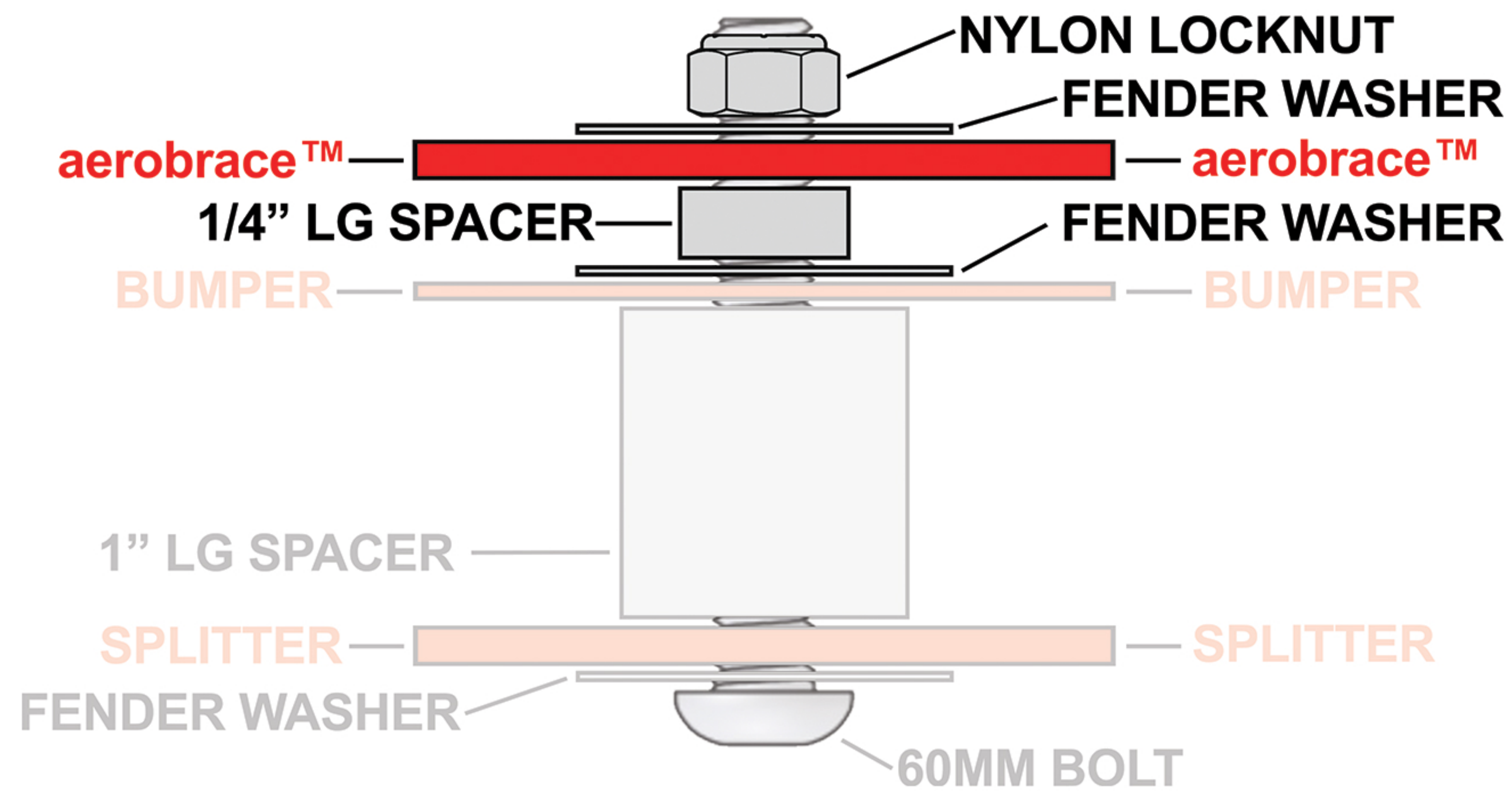

NOTES:

1. Desaturated Hardware in diagram indicates previously installed.
2. Check bolt threads for plastic debris before threading locknuts.
3. Do not overtighten Hardware.

12. Turn Bumper back upside down to tighten all fasteners from **HARDWARE (B)**.

-VW MK7 GOLF TSI/TDI Front Splitter

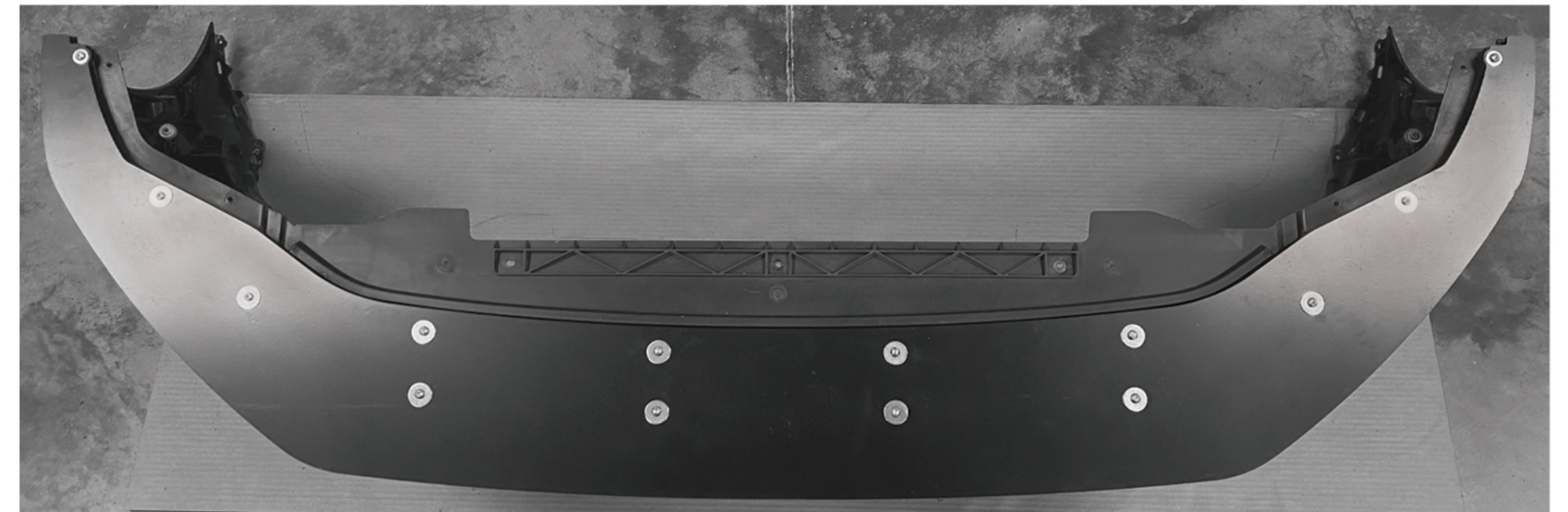

-VW MK7 GOLF TSI/TDI aerobraces™



13. Inspect all Hardware for tightness to complete Front Splitter installation.