

**INSTALLATION GUIDE:  
VW MK7 GTI - REAR DIFFUSER (STREET EDITION)**

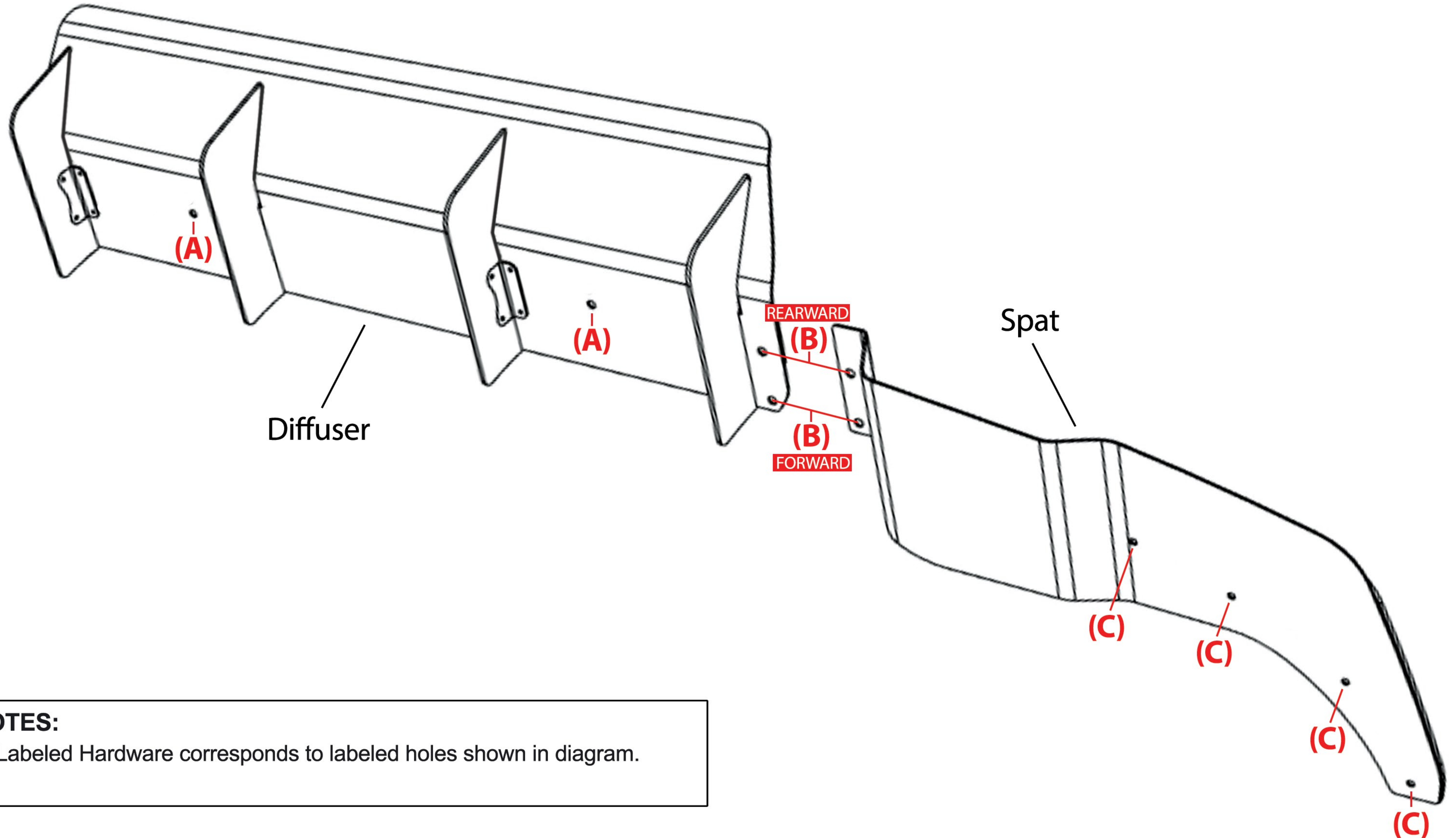

**NOTES:**  
1. Labeled Hardware corresponds to labeled holes shown in diagram.



## INSTALLATION GUIDE: VW MK7 GTI - REAR DIFFUSER (STREET EDITION)

### HARDWARE (A)

QTY	DESCRIPTION
2	1/4-20 X 1" BOLT (BLK OX)
2	1/4" X .625 OD WASHER (BLK OX)
2	1/4-20 17/32 HOLE CENTER U-NUT (BLK OX)

### HARDWARE (B)

QTY	DESCRIPTION
4	1/4-20 X 1" BOLT (BLK OX)
4	1/4" X .625 OD WASHER (BLK OX)
4	M6 X 18MM OD WASHER
4	1/4-20 LOCKNUT

### HARDWARE (C)

QTY	DESCRIPTION
8	#8 x 3/4" LG SELF-TAP SCREW (BLK ZINC)
8	#8 X .438" OD SS WASHER (BLK OX)

## MAKE THE FOLLOWING TOOLS READY FOR USE

- Drill •1/4" Drill Bit •9/64" Drill Bit •T-15 Torx
- 5/32" Hex Wrench •7/16" Wrench •Phillips Screwdriver
- Medium Threadlock •Light Colored Marking Tool

aerofabb, LLC is not responsible for damage to you or your vehicle while following this Install Guide and/or installing aerofabb products. Professional install is recommended.

### NOTES:

1. CONFIRM NO HARDWARE IS MISSING BEFORE INSTALL.

1. Using a **T-15 Torx**, remove the two Factory Plastic Screws and Snap Retainers from bottom side of valance.

*-TIP: Once Plastic T-15 Torx Screws are removed, lightly pull down on back edge of Factory Valance. This will pop out Plastic Retainers with ease.*

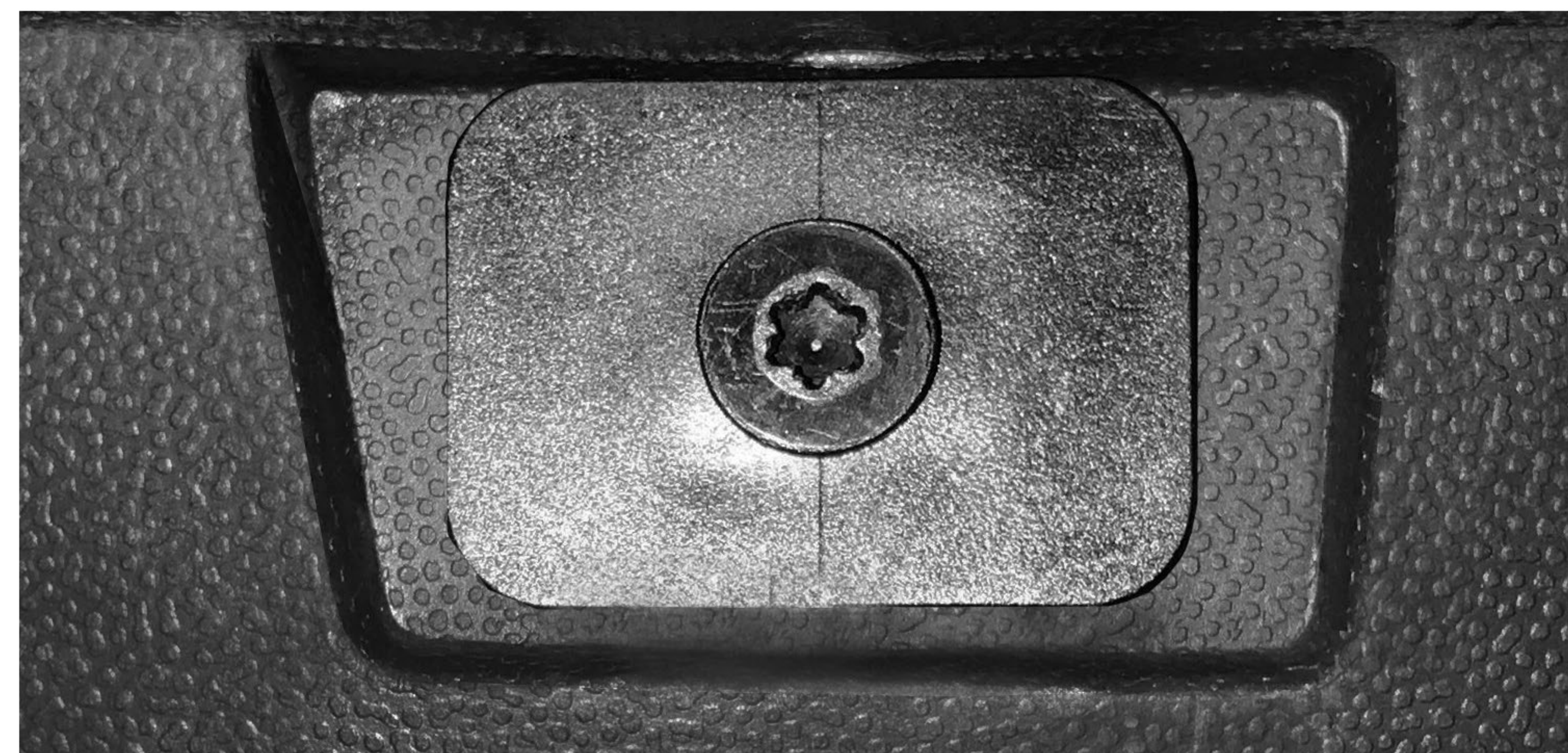

2. Clean the top and bottom of Factory L-brackets to rid of any road grime/debris. Slide the provided U-Nuts from **HARDWARE (A)** onto each Factory L-Bracket as shown.

*-U-Nut "Clicks" when properly set into place. Threaded channel of U-Nut faces up.*

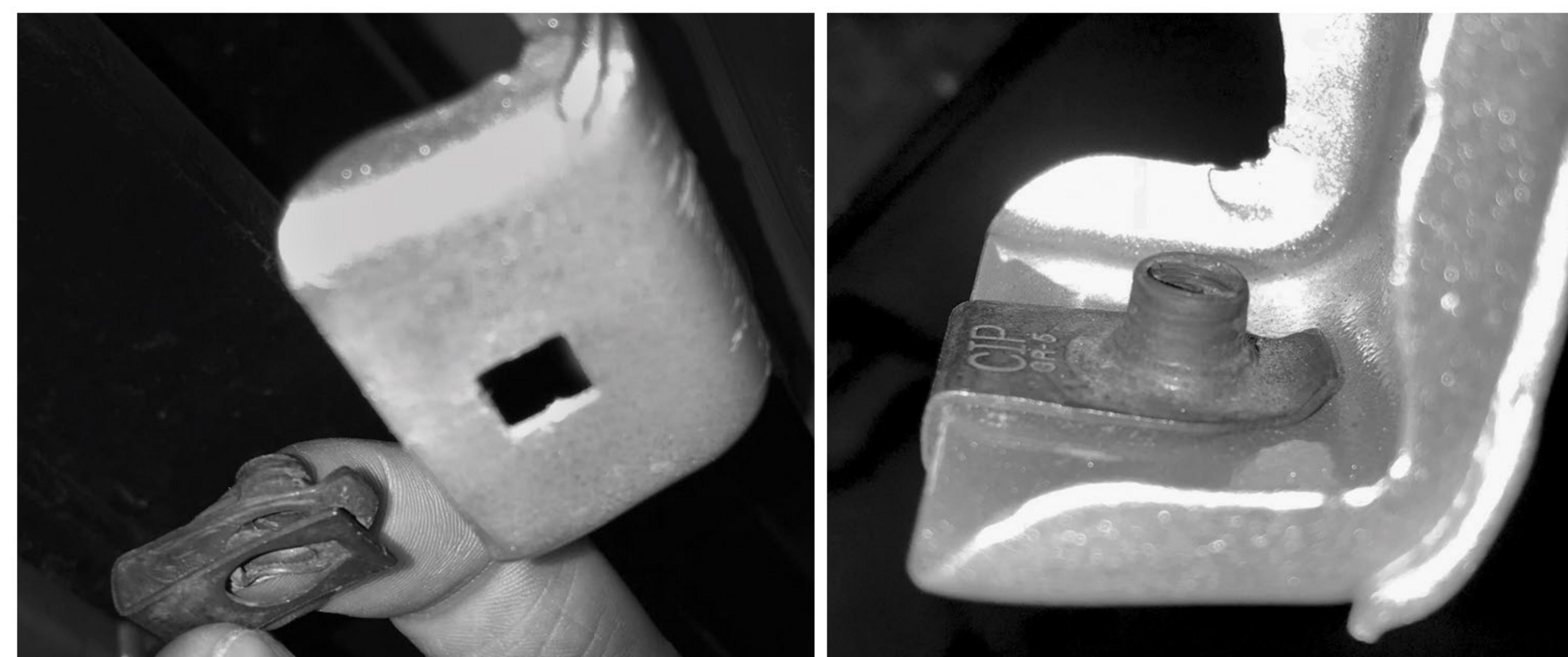



## INSTALLATION GUIDE: VW MK7 GTI - REAR DIFFUSER (STREET EDITION)

3. Place the aerofabb Rear Diffuser over the Factory Valance and align Diffuser holes (A) with the threads of U-Nuts. Using the recommended **Medium-Threadlock** and a **5/32" Hex**, install remaining **HARDWARE (A)** through Diffuser holes (A) threading into U-Nuts and tighten.

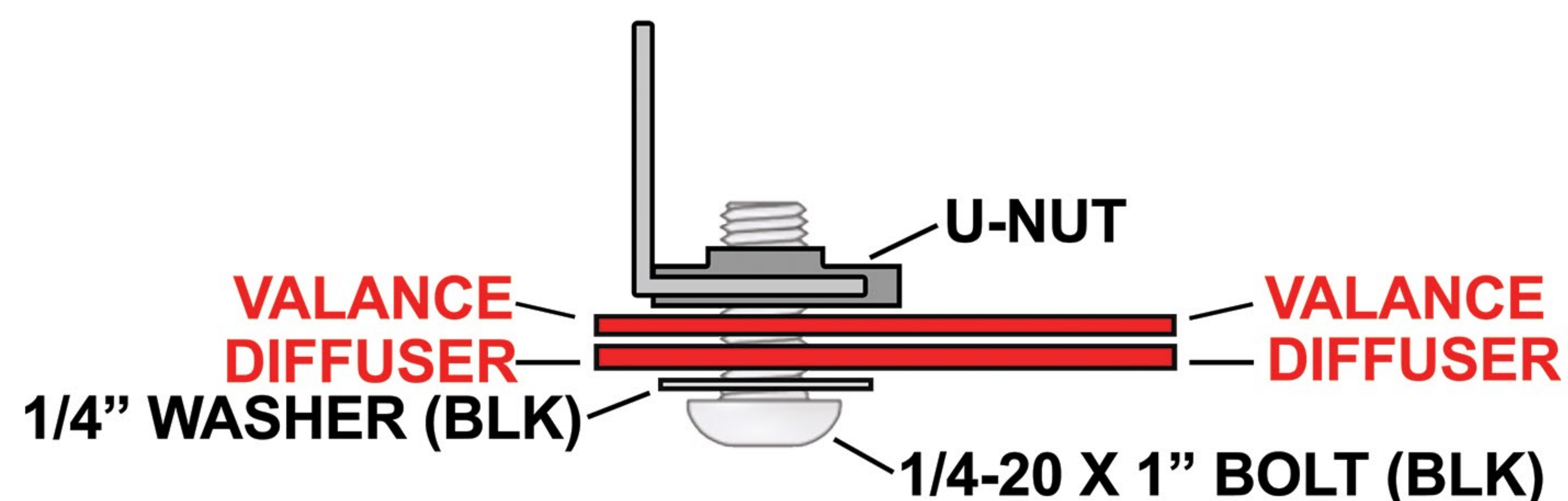

4. With **HARDWARE (A)** installed and Diffuser secured to the chassis, use a **1/4" Drill Bit** to drill through the two most **REARWARD** Diffuser holes (B) into the Factory Valance. (the two most **FORWARD** holes do not require drilling)

5. Using a **5/32" Hex** and **7/16" Wrench**, install **HARDWARE (B)** through Spat holes (B) and into Diffuser holes (B) but do not tighten completely.

*-Black Washers install on bottom side. Silver Washers install on top side followed by Lock Nut.*

*-Spats mount on **BOTTOM** side of Diffuser\**

6. Starting on which ever side (Right or Left), hold Spat up to bottom side of Factory Valance. Align the front edge of Spat closest to rear wheels with the edge of Factory Valance.

*-Front edge of Spat and Valance should match/sit flush with one another as shown in photo.*

### NOTES:

1. DO NOT OVER TIGHTEN HARDWARE!
2. Factory L-Brackets may require slight bending forwards or backwards if Diffuser does not seem to be aligned properly.



7. With the Side Spats aligned correctly, use a **Light Colored Marking Tool** to mark through the pre-drilled Spat holes (C) and onto bottom side of Factory Valance. With holes marked, remove **HARDWARE (B)** and Spats.

***-IMPORTANT:** As shown below, markings on surface should be placed in center of ledge.*

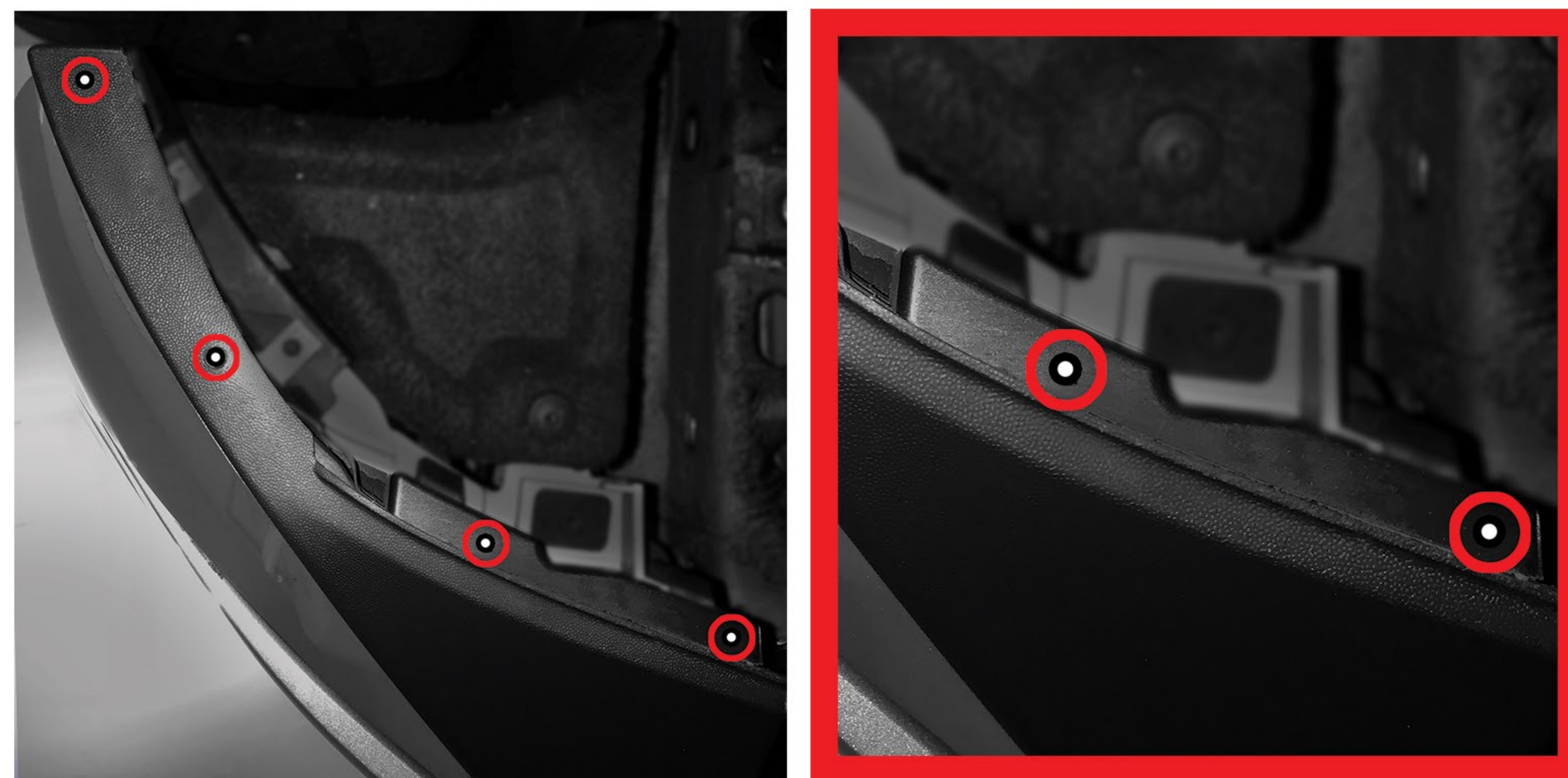

8. Using a **9/64" Drill Bit**, create pilot holes by drilling through all four of your markings on bottom of Valance.

9. With pilot holes drilled, loosely reinstall Spats using **HARDWARE (B)** and align the pre-drilled holes with your pilot holes. Using a **Phillips Screwdriver**, install **HARDWARE (C)** through holes (C) and into Valance. Tighten **HARDWARE (C)** until snug/Spats sit flush with Valance. Fully tighten **HARDWARE (B)** and repeat on opposite side.

***-IMPORTANT:** Screws are self tapping but may require some additional pressure to be applied before they begin to thread. **DO NOT OVER TIGHTEN!***

**\*INSPECT ALL HARDWARE FOR TIGHTNESS TO COMPLETE INSTALLATION\***