

INSTALLATION GUIDE: AWE C7 CORVETTE TRACK OR TOURING EXHAUST

THIS PRODUCT IS INTENDED FOR THE FOLLOWING VEHICLES*:

YEAR	MAKE	MODEL	SUBMODEL	ENGINE
2013-2019	Chevrolet	Corvette	Stingray	6.2L V8
2017-2019	Chevrolet	Corvette	Grand Sport	6.2L V8
2015-2019	Chevrolet	Corvette	Z06	6.2L V8 Supercharged
2019	Chevrolet	Corvette	ZR1	6.2L V8 Supercharged

THIS GUIDE IS INTENDED FOR THE FOLLOWING PART NUMBERS:

3010-11100	AWE Non-Resonated Performance X-Pipe for C7 Corvette Stingray / Grand Sport / Z06 / ZR1
3020-42071	AWE Track Edition Valve-back Exhaust for C7 Corvette Stingray / Grand Sport Auto - Chrome Silver Tips
3020-43079	AWE Track Edition Valve-back Exhaust for C7 Corvette Stingray / Grand Sport Auto - Diamond Black Tips
3015-42131	AWE Touring Edition Valve-back Exhaust for C7 Corvette Stingray / Grand Sport Auto - Chrome Silver Tips
3015-43141	AWE Touring Edition Valve-back Exhaust for C7 Corvette Stingray / Grand Sport Auto - Diamond Black Tips
3020-42073	AWE Track Edition Axle-back Exhaust for C7 Corvette Z06 / ZR1 / Grand Sport Manual - Chrome Silver Tips
3020-43081	AWE Track Edition Axle-back Exhaust for C7 Corvette Z06 / ZR1 / Grand Sport Manual - Diamond Black Tips
3015-42133	AWE Touring Edition Axle-back Exhaust for C7 Corvette Z06 / ZR1 / Grand Sport Manual - Chrome Silver Tips
3015-43143	AWE Touring Edition Axle-back Exhaust for C7 Corvette Z06 / ZR1 / Grand Sport Manual - Diamond Black Tips

Welcome to the AWE family, and congratulations on your purchase of the **AWE Track Edition or Touring Edition Exhaust** system for the C7 Corvette.

Exquisite build quality and craftsmanship, coupled with industry leading performance, distinguish this exhaust system from all others.

*For up to the minute fitment information, be sure to visit the AWE website. As always, AWE Performance Specialists are standing by for any questions, [right here](#).

PARTS LIST



INSPECT ALL PARTS PRIOR TO DISASSEMBLY OF VEHICLE; CONFIRM NO PARTS ARE DAMAGED OR MISSING, PLEASE CONTACT THE PLACE OF PURCHASE IMMEDIATELY IF ANY ISSUES.

Performance X-Pipe 3010-11100

QTY	Description	Part Number
1	C7 Corvette X-Pipe	B84
2	2.75in Accu-Seal clamps	TAS275
4	M10-1.5 x 60mm hex head bolt	91287A377
4	M10-1.5 hex head nut	90591A171
4	M10 split lock washer	91202A242
8	M10 flat washer	93475A280

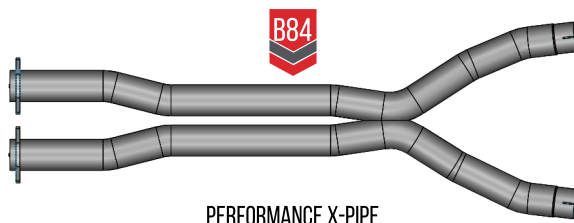

Axle-Back Exhaust

QTY	Description	Part Number
1	C7 Corvette DS axle tube	B85
1	C7 Corvette PS axle tube	B86
2	3.00in Accu-Seal clamps	TAS300
4	M8-1.25 x 25mm socket head cap bolt	91292A148
4	M8-1.25 locknut	94920A500
4	4.5in exhaust tip	61000078 (Chrome) or 61000078-BLK (Black)
4	Exhaust tip barrel clamps	BHM8X079SS00C
1	Heat-reflective wrap-around sleeving	2627K33 - cut to length
1	C7 Corvette rear center plate	110032
2	Cable ties	7130K59

Touring System Only

1	C7 Corvette DS Touring rear section	B87
1	C7 Corvette PS Touring rear section	B88

Track System Only

1	C7 Corvette DS Track rear section	B89
1	C7 Corvette PS Track rear section	B90

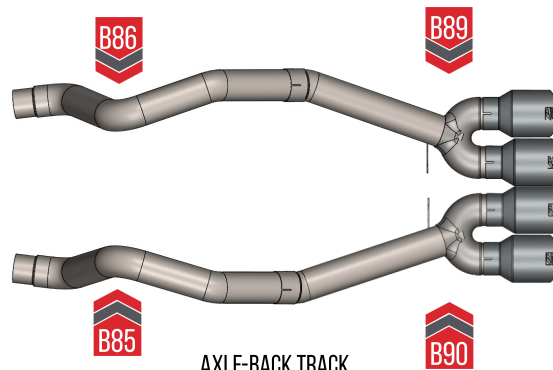
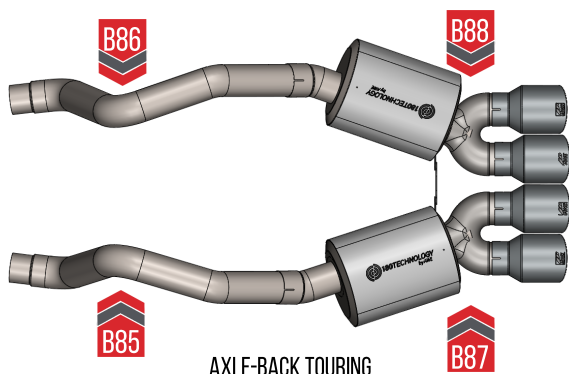

PARTS LIST



INSPECT ALL PARTS PRIOR TO DISASSEMBLY OF VEHICLE; CONFIRM NO PARTS ARE DAMAGED OR MISSING, PLEASE CONTACT THE PLACE OF PURCHASE IMMEDIATELY IF ANY ISSUES.

AFM Valve-Back Exhaust

- | | | |
|---|--------------------------------------|---|
| 2 | 2.50in Accu-Seal clamps | TAS250 |
| 4 | M8-1.25 x 25mm socket head cap bolt | 91292A148 |
| 4 | M8-1.25 locknut | 94920A500 |
| 4 | 4.5in exhaust tip | 61000078 (Chrome) or 61000078-BLK (Black) |
| 4 | Exhaust tip barrel clamps | BHM8X079SS00C |
| 1 | Heat-reflective wrap-around sleeving | 2627K33 - cut to length |
| 1 | C7 Corvette rear center plate | 110032 |
| 2 | Cable ties | 7130K59 |

Touring System Only

- | | | |
|---|---|-----|
| 1 | C7 Corvette AFM DS Touring rear section | C06 |
| 1 | C7 Corvette AFM PS Touring rear section | C07 |

Track System Only

- | | | |
|---|---------------------------------------|-----|
| 1 | C7 Corvette AFM DS Track rear section | C08 |
| 1 | C7 Corvette AFM PS Track rear section | C09 |

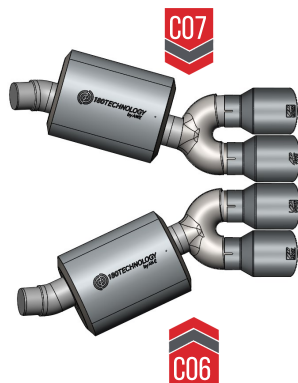

VALVE-BACK TOURING

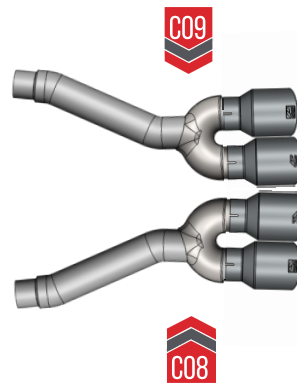

VALVE-BACK TRACK

STEP 1

For the installation of the **Performance X-pipe** skip to step 27.

Installation of the **AWE Axle Back** exhaust system is the reverse of the OEM exhaust removal.



Always refer to the manufacturer service manual for precise torque specifications on all OEM fasteners.



CAUTION: The exhaust may be **VERY HOT** — allow adequate time for the system to cool down before disassembly. Severe burns and injury will occur if skin comes into contact with a hot exhaust system.

Start by removing the rear bumper valance by removing the license plate, to access to the two bolts shown in **Figure 1**.



FIGURE 1

STEP 2

Remove the two bolts above the exhaust tip outlets, shown in **Figure 2**.

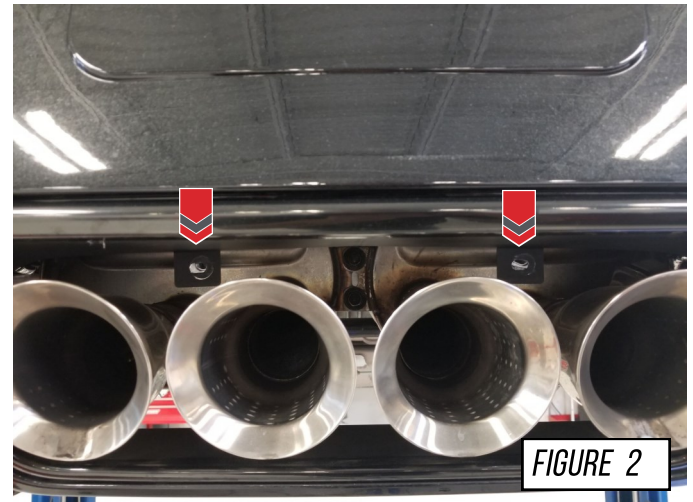

FIGURE 2

STEP 3

Remove the 10 bolts found along the bottom of the rear valance, 5 per side, shown in **Figure 3**.

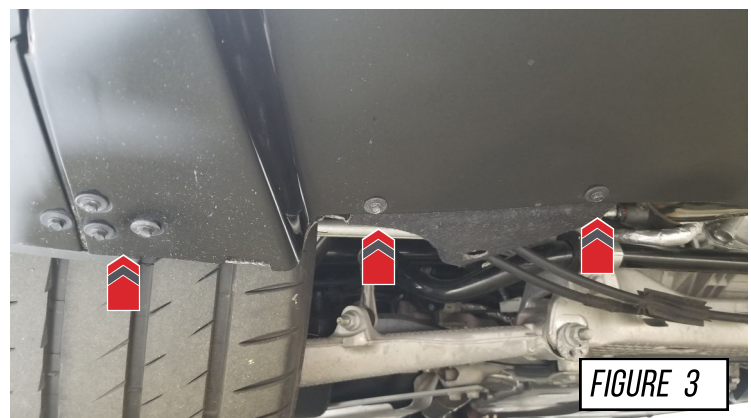

FIGURE 3

STEP 4

Remove the driver and passenger side plastic grill inserts by pushing them out from the inside. These are held into place with 6 clips shown in **Figure 4**.



You may use painters tap to protect the paint, but is not required.



STEP 5

Remove the two rear reflectors shown in **Figure 5-1** by pushing them out from the inside of the bumper. Each one is held in with 3 clips.



With the reflectors out of the way, you now have access to 4 bolts, two on each side to be removed shown in **Figure 5-2**.



STEP 6

Remove the rear valance from the car, this is done by unclipping the top corners and carefully pulling the part away from the car.

STEP 7

For **Non-NPP** exhaust skip this step.

For NPP vehicles, unplug the driver and passenger side rear valve harness wires from the valve motor, shown in **Figure 7**. This can be accomplished by disengaging the grey lock tab and squeezing the harness plug.

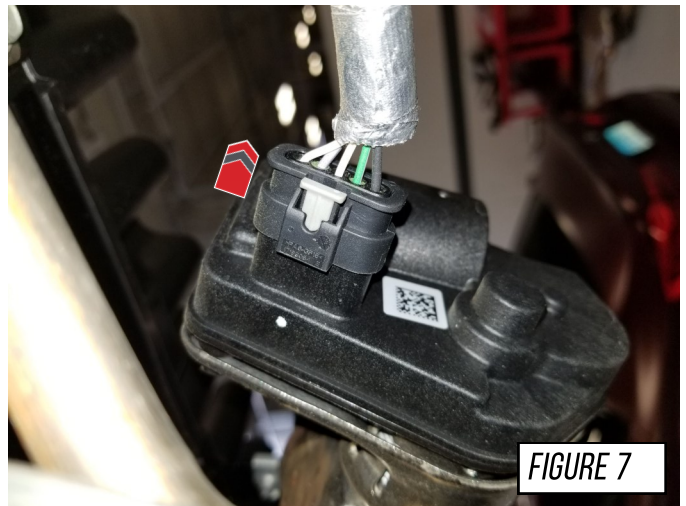

FIGURE 7

STEP 8

Remove the two bolts holding the rear mufflers together, as shown in **Figure 8-1**.

Detach the rear muffler hanger, by removing the two bolts from each side shown in **Figure 8-2**.

 Save these hanger bracket bolts as they will be used when installing the new exhaust.



FIGURE 8-1

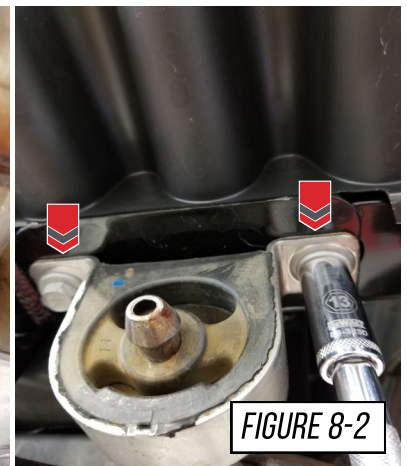

FIGURE 8-2

STEP 9

For **Manual** vehicles skip this step.

Automatic vehicles ONLY:

To remove the driver side exhaust tube, you need to shift the vehicle into neutral. This will allow enough space around the shift linkage on the transmission for the exhaust tube to slide out, as shown in **Figure 9**.

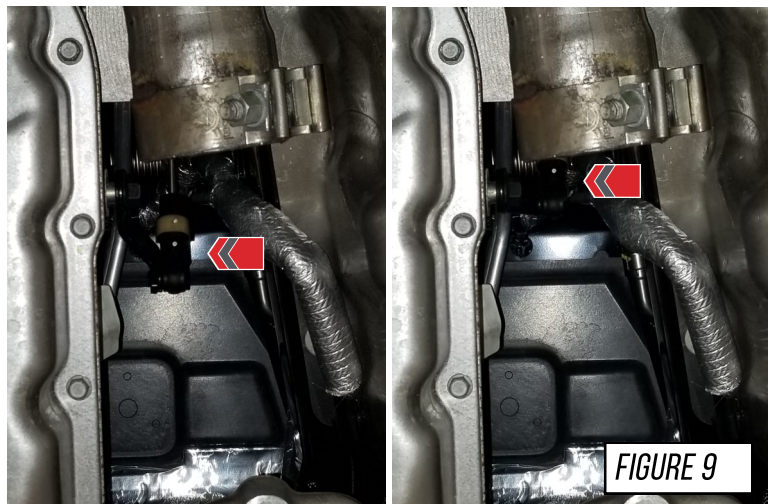
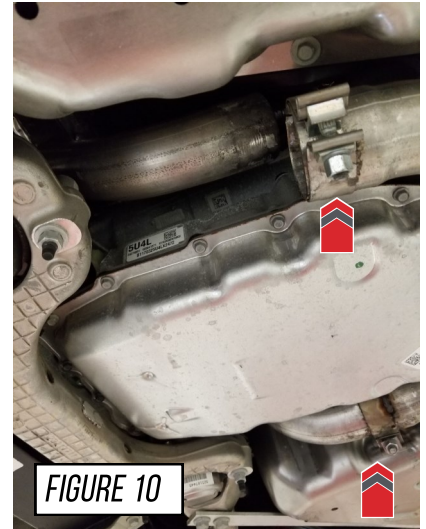

FIGURE 9

STEP 10

Loosen the driver and passenger clamp bolts shown in **Figure 10**. This will allow you to remove both rear sections of the exhaust.



STEP 11

Pivot the driver and passenger side exhaust tubes down from the rear of the vehicle and remove as shown in **Figure 11**.



The exhaust mount on the rear section will need to be removed and reused during the installation of your new exhaust.

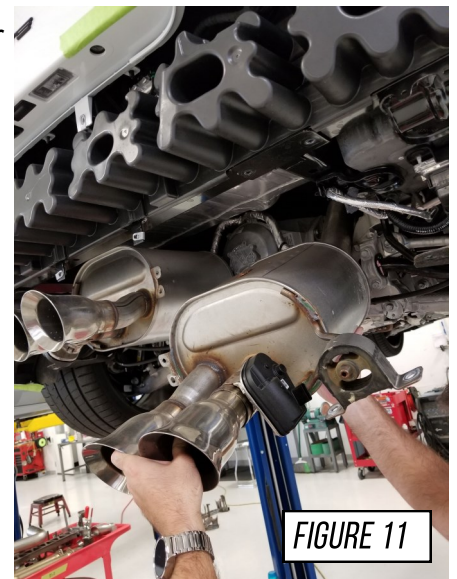

STEP 12

Non-NPP vehicles skip this step.

With all components removed, secure the NPP valve harness to the chassis, with cable ties, as seen in **Figure 12**.



STEP 13

Cut the supplied 10in section of heat wrap in half and use it to cover the braided sections of transmission lines shown in **Figure 13-1**. To do so, you may need to remove the bolt holding the lines in place, then wrap the heat shield around the two lines. With the heat shield on, use the supplied zip ties to ensure the line is secured out of the way as shown in **Figure 13-2**.



Some very minor tweaking of the aluminum lines may be required to get the desired **relaxed** fitment, be very careful not to damage the lines.

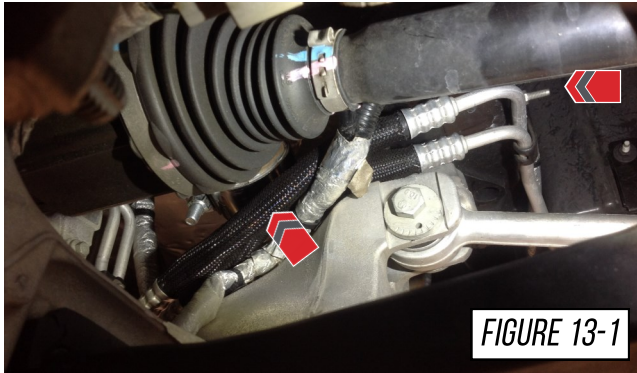

FIGURE 13-1

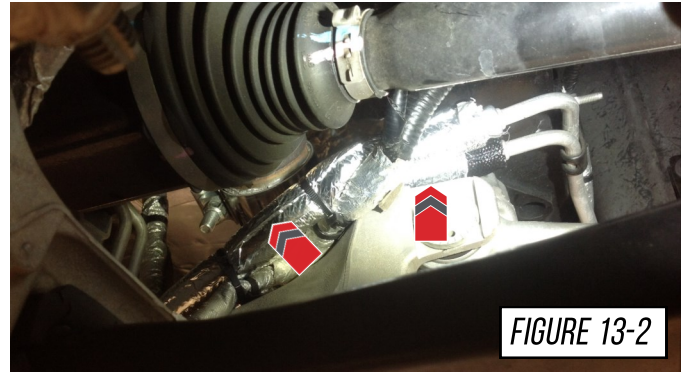
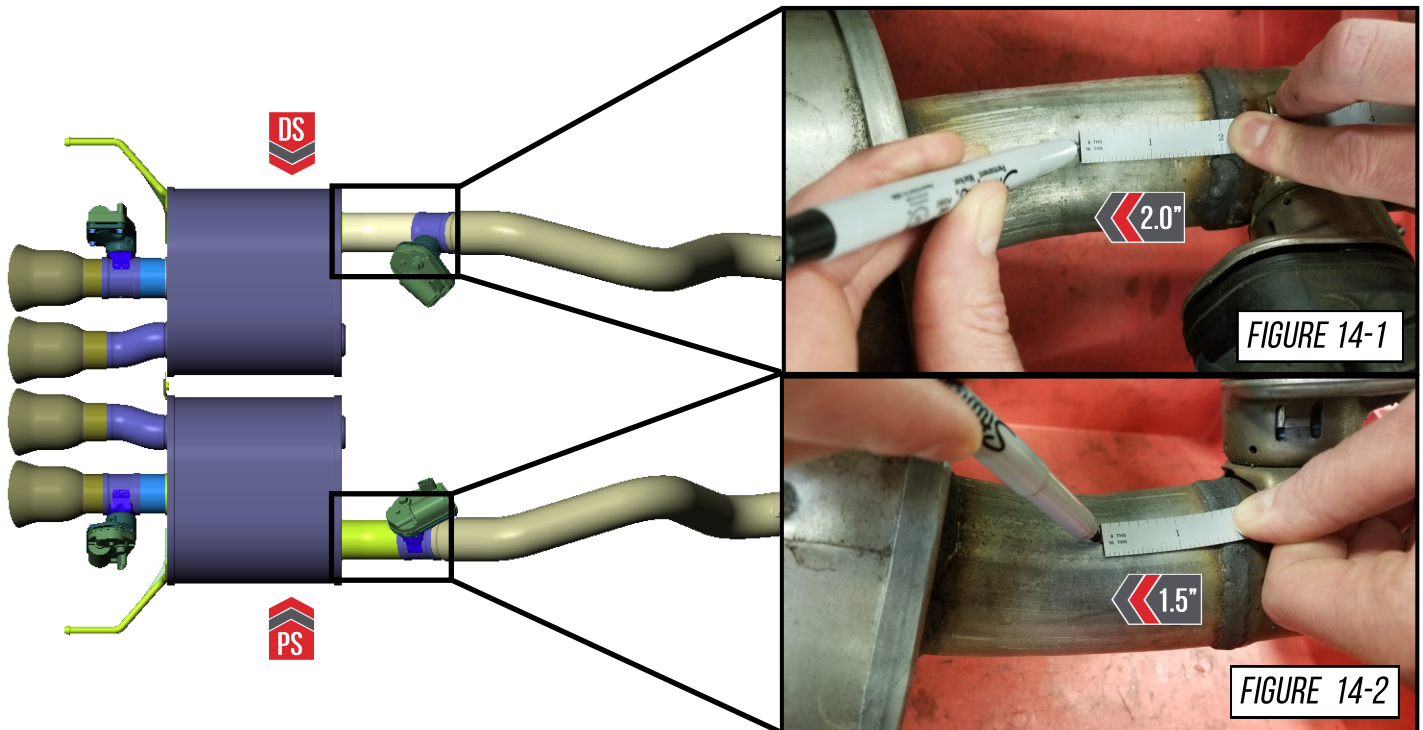

FIGURE 13-2

STEP 14

Non-AFM vehicles skip this step.

For AFM vehicles, to install the axle back system, you will need to cut the driver and passenger side factory rear sections between the valve and the rear muffler. Measuring from the valve, the driver side tube is cut 2in from the end of the weld, as seen in **Figure 14-1**. The passenger side is cut to 1.5in from the end of the weld, as seen in **Figure 14-2**.



STEP 15



Always wear safety glasses when working with power tools.

When cutting the tube, make the cut as straight as possible as seen in **Figure 15**. After you cut the driver and passenger side tubes, deburr the cut end to allow for a proper seal with your AWE axle back system.

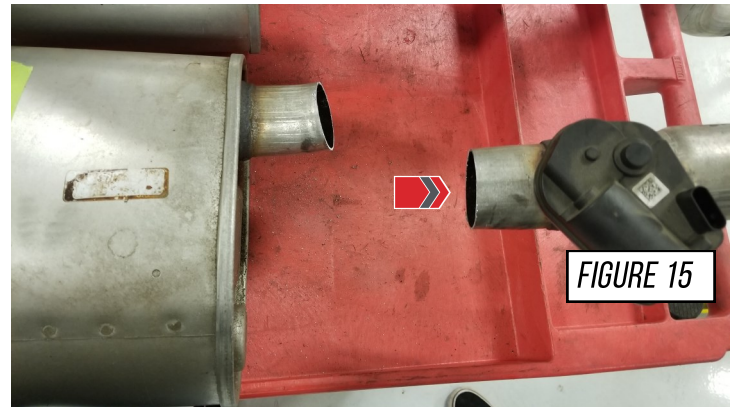

FIGURE 15

STEP 16

Install the two over axle tubes from the front of the vehicle so that the tubes are visible from the rear as shown in **Figure 16**. Ensure you install the driver and passenger tube on the correct side.



For **AFM** vehicles, the factory rear section that was cut in step 14 will be reinstalled here.

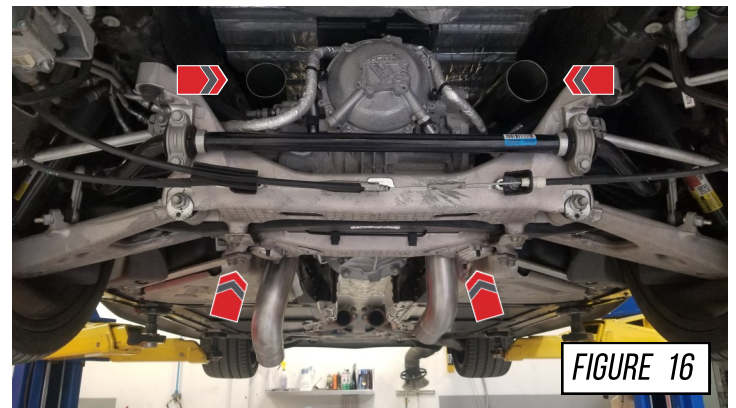

FIGURE 16

STEP 17

Install the factory rear hangers and the Accu-Seal clamps onto your AWE driver and passenger side rear sections of the exhaust, as seen in **Figure 17**.

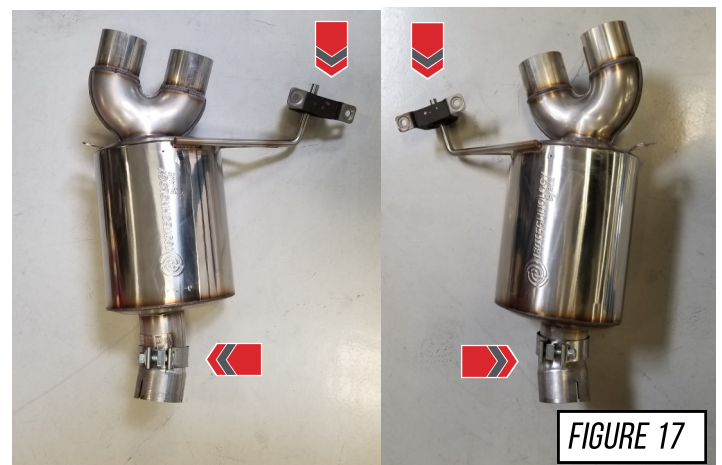

FIGURE 17

STEP 18

It is crucial to install each section and Accu-Seal clamp correctly to prevent loose joints, exhaust leaks between the tubing connections and rattles.

Arrow A in **Figure 18** shows the expanded pipe and the preinstalled Accu-Seal clamp being brought up to the corresponding pipe.

Arrow B in **Figure 18** shows the overlapping pipe installed correctly over the corresponding pipe.

Arrow C in **Figure 18** shows the Accu-Seal clamp being brought to the edge of the expanded pipe.



NOTES:

- **Do not** torque any Accu-Seal clamp until the entire exhaust has been installed and adjusted.
- Torque specification is a minimum of 60 ft/lbs

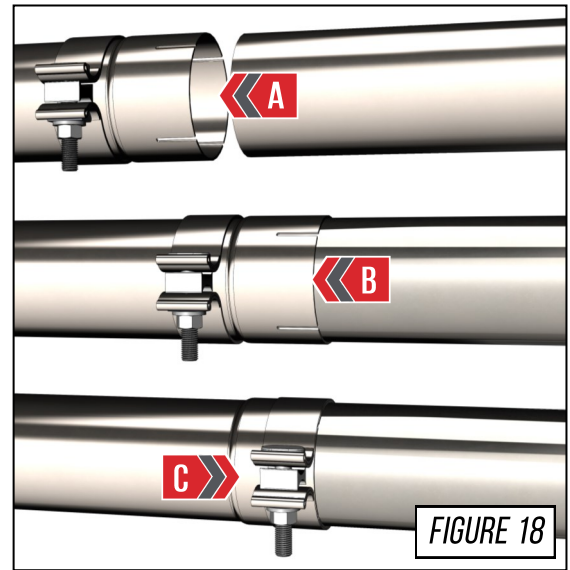

FIGURE 18

STEP 19

Non-AFM systems skip to the next step.

Reinstall the modified factory over-axle sections of the exhaust into the vehicle by slipping the AWE rear section over the cut and deburred over axle tube. Hand tighten the Accu-seal clamps and reconnect the valves as seen in **Figure 19**.



FIGURE 19

STEP 20

AFM vehicles skip this step.

Install the rear driver and passenger sections onto the over axle tube, ensure the slip joint is fully pressed together as seen in **Figure 20**. Hand tighten the Accu-seal clamps.



FIGURE 20

STEP 21

With the rear sections of the exhaust in place, use the factory hardware you removed earlier to reinstall the rear hangers, as shown in **Figure 21**.

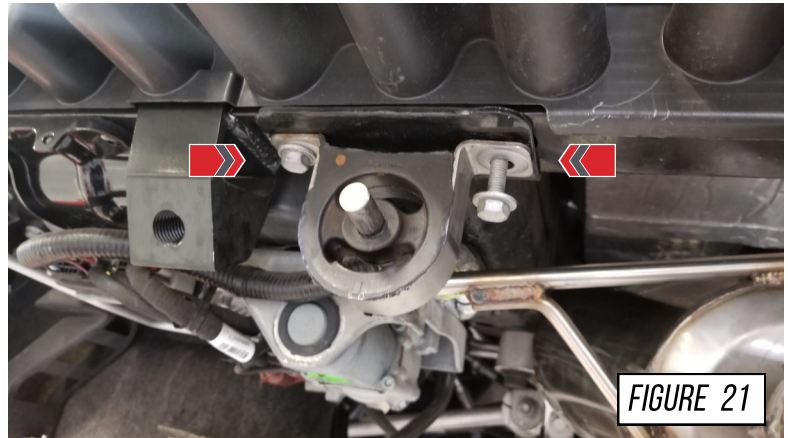

STEP 22

With both rear sections in place as shown in **Figure 22-1**, gather the AWE exhaust plate and provided hardware to bolt together the driver and passenger side section with the plate installed towards the rear of the vehicle as shown in **Figure 22-2**.



Hand tighten all bolts first to allow for correct alignment.

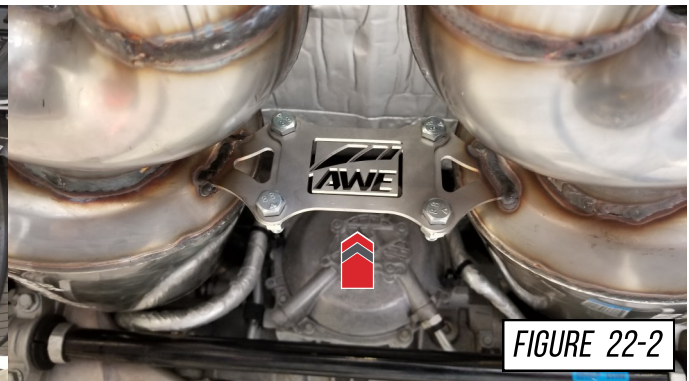
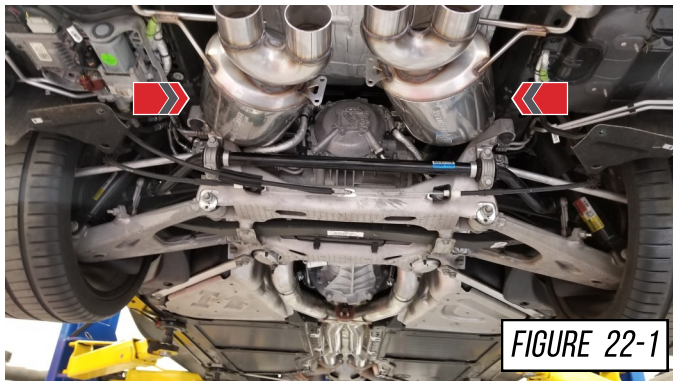

STEP 23

As mentioned in step 19 and 20, prior to this step all joints and clamps should be snug but not fully tightened down.

Make sure to adjust the orientation of the system so that the exhaust tubes have plenty of clearance from any parts of the chassis, braces, and heat shields. Once the system is oriented correctly, tighten down the clamps as shown in **Figure 23**.



NOTE: To ensure your perfect fitment, take your time to adjust your system properly

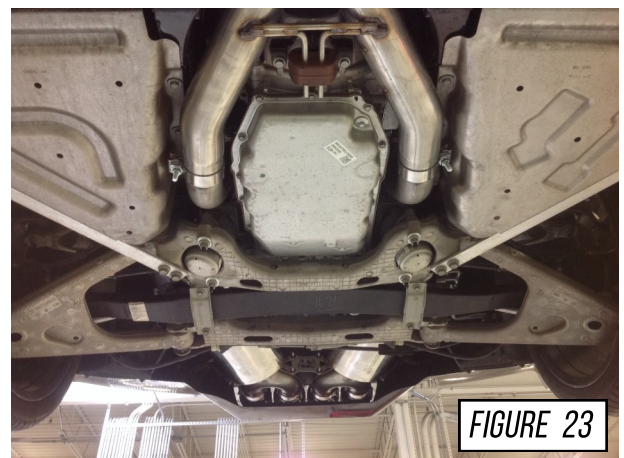

STEP 24

Now reinstall the rear bumper sections, this process is the opposite of steps 1 through 6.



Be careful not to scratch the paint on the body.

STEP 25



Make sure to apply anti-seize on all barrel clamp bolts.



STEP 26

Go back across the exhaust system one last time to check for contact and tighten the Accu-seal clamps. Accu-seal clamps should be tightened to at least 60 ft-lbs and the tubes should be adjusted so that the tips sit evenly in the rear bumper. At this point installation is complete!



ENJOY!



STEP 27

Installation of the **AWE X-pipe** exhaust system is the reverse of the removal OEM exhaust.



Always refer to the manufacturer service manual for precise torque specifications on all OEM fasteners.



CAUTION: The exhaust may be **VERY HOT** — allow adequate time for the system to cool down before disassembly. Severe burns and injury will occur if skin comes into contact with a hot exhaust system.

Remove the factory aluminum shield from the bottom of the vehicle as shown in **Figure 27**, this is held in place

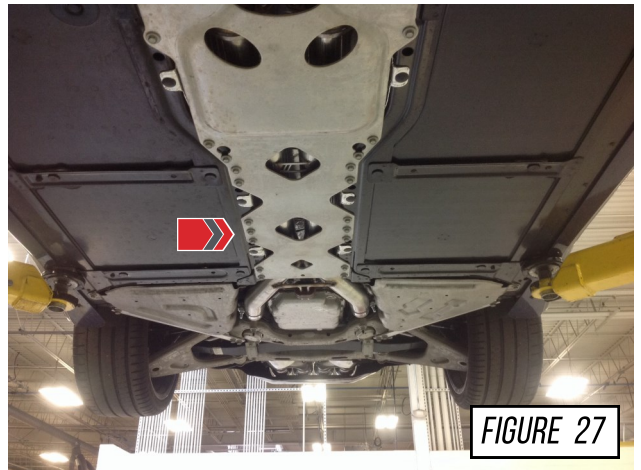

FIGURE 27

STEP 28

Remove the four bolts connecting the X-pipe to the down pipes as shown in **Figure 28**.

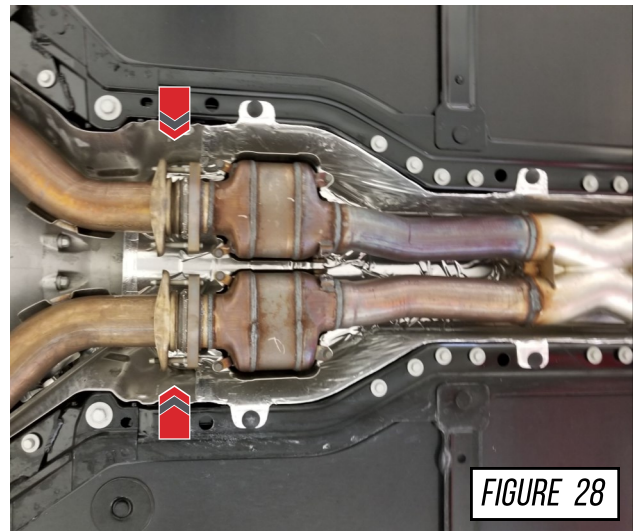

FIGURE 28

STEP 29

Remove the factory hanger by removing the two bolts as shown in **Figure 29**.

NOTE: Figure shows the hanger assembly for automatic vehicles. Manual hanger assembly is slightly different, but process is the same.



Save the hardware and hanger, as you will reinstall these with your new AWE X-pipe.

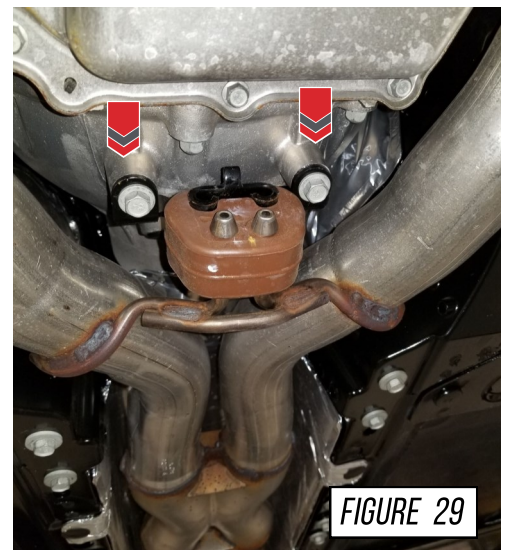
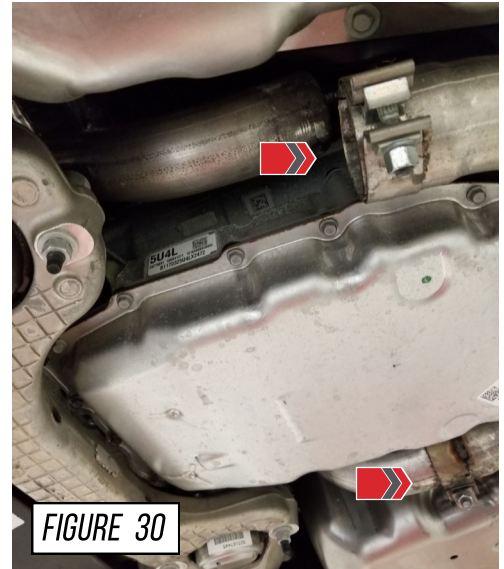

FIGURE 29

STEP 30

Loosen the driver and passenger side factory clamps as shown in **Figure 30**.

Pivot the factory X-pipe down and forward out of the vehicle to separate it from the over axle tubes.



STEP 31

Remove the X-pipe hanger from the factory X-pipe as shown in **Figure 31**. This will be reused with your AWE exhaust.



STEP 32

Remove the two donut gaskets from the factory X-pipe, you can use a small flat object to pry them off, be very careful to not damage these gaskets. If your gasket is heavily worn make sure to replace it with a new gasket as shown in **Figure 32**. Contact your local dealership for a replacement gasket if needed.



STEP 33

Install the factory hanger and two donut gaskets in the same orientation it was removed, along with the supplied Accu-Seal clamps onto your AWE X-pipe as shown in **Figure 33**.

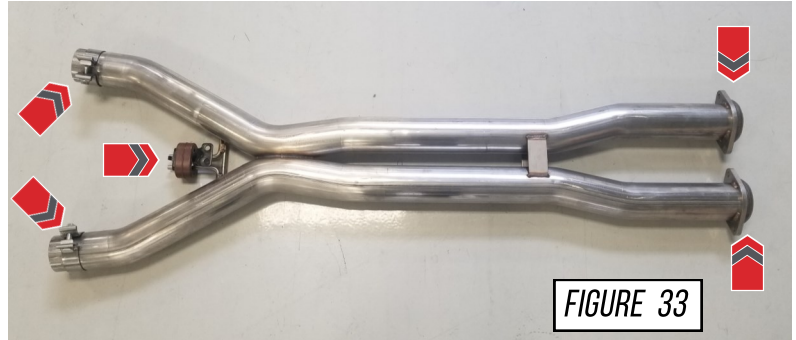

STEP 34

It is crucial to install each section and Accu-Seal clamp correctly to prevent loose joints, exhaust leaks between the tubing connections and rattles.

Arrow A in **Figure 34** shows the expanded pipe and the preinstalled Accu-Seal clamp being brought up to the corresponding pipe.

Arrow B in **Figure 34** shows the overlapping pipe installed correctly over the corresponding pipe.

Arrow C in **Figure 34** shows the Accu-Seal clamp being brought to the edge of the expanded pipe.



NOTES:

- **Do not** torque any Accu-Seal clamp until the entire exhaust has been installed and adjusted.
- Torque specification is a minimum of 60 ft/lbs

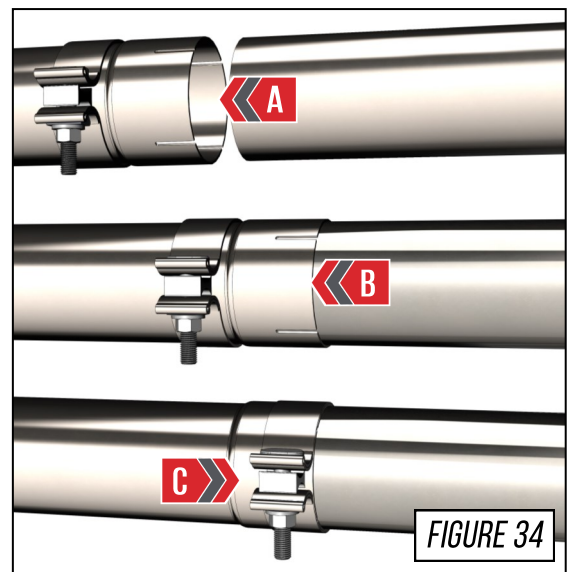

STEP 35

Install the X-pipe slip joints onto the rear axle back tubes, only hand tighten the Accu-seal clamps at this point as shown in **Figure 35**.

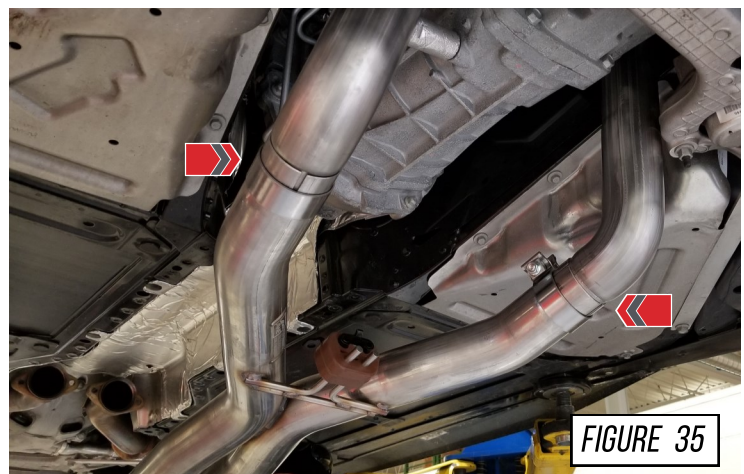

STEP 36

Install the flange side, again being careful to not damage the gaskets. Use the supplied hardware and tighten the bolts as shown in **Figure 36**.

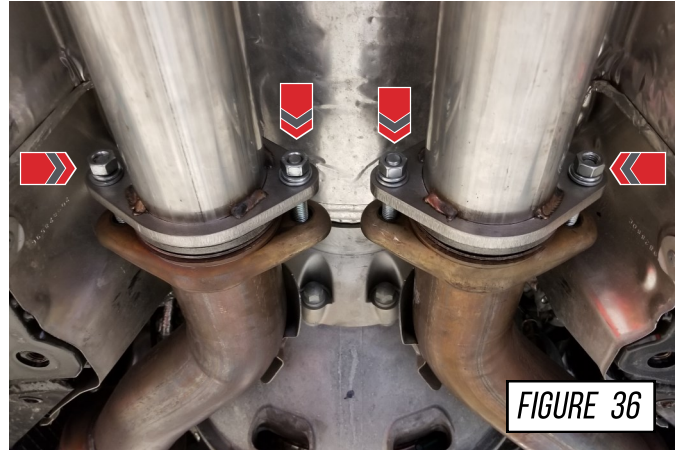

STEP 37

Reinstall the factory hanger assembly and hardware into vehicle and tighten the bolts as shown in **Figure 37**.

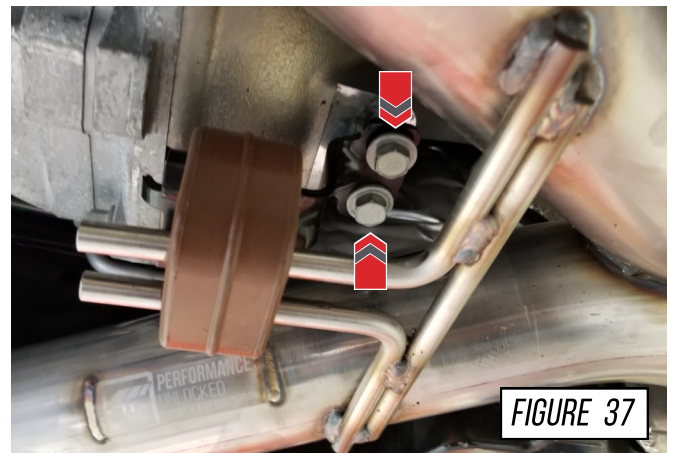

STEP 38

Check that the fitment of the X-pipe is correct and not touching any parts of the vehicle.

With your X-pipe in the correct orientation tighten the Accu-Seal clamps shown in **Figure 38**.

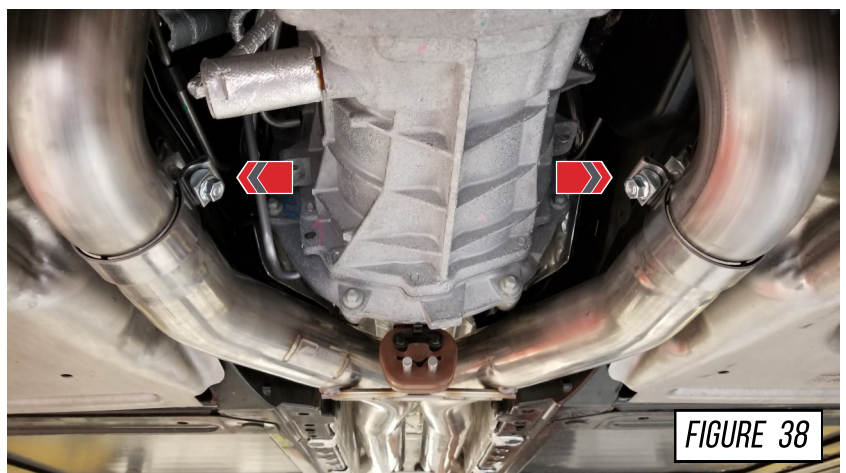

STEP 39

Reinstall the factory aluminum shield shown in **Figure 39** with the 24 bolts you removed in step 27 and tighten to factory spec.

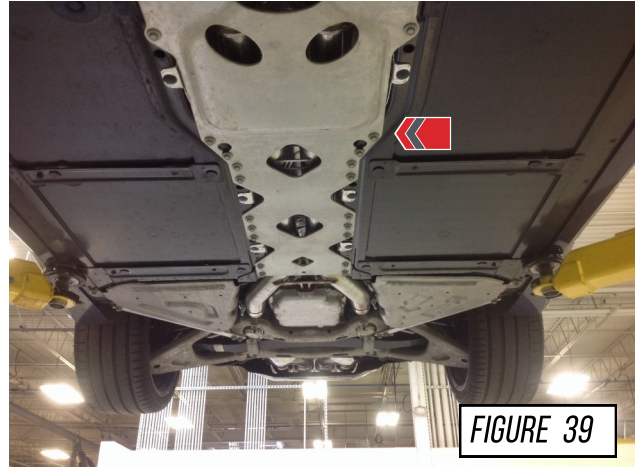

STEP 40

To complete your installation, go over any removed components to ensure everything is installed correctly and tighten all clamps.

ENJOY!



TROUBLESHOOTING

Issue	Solution
Exhaust is not fitting correctly	Most fitment issues are due to improperly adjusted exhaust. This includes tip fitments and rattling due to chassis contact. Check out our fitment guide for more installation tips.
Wrong or missing parts	Double check the parts list for your system and compare them with what you received. Fill out our contact form, found below and let us know what parts you need.

CARE

Once installed properly, your AWE exhaust will provide years of trouble-free performance.

The exhaust volume and sound will settle with usage; 800-1000 miles is required to break-in new exhaust systems.

Also, please note that the rear **180Technology®** resonator has a small drain hole to allow condensation to escape. Water drops from this area are normal.

Periodic cleaning of exhaust tips is necessary to maintain proper finish, especially in areas prone to road salt and caustic deicing solutions. Use a mild soap and water solution or car wax to clean the finish. Avoid using abrasive polishes, as they can scratch the finish.

Any questions or comments,
please do not hesitate to contact us:

AWE
199 Precision Drive
Horsham, PA 19044
215-658-1670
[CONTACT FORM](#)

WARRANTY

Up-to-date warranty information is found [HERE](#).