

# **Weistec M156/M159**

---

## **ENGINE**

### **ARP Cam Cap Bolts Installation Guide**



- 2007-2011 S63 AMG
- 2007-2011 ML63 AMG
- 2007 R63 AMG
- 2007-2008 CLK63 AMG
- 2008 CLK63 Black Series
- 2007-2011 CLS63 AMG
- 2008-Present C63 AMG (Sedan and Wagon)
- 2007-Present E63 AMG (Sedan and Wagon)
- 2008-2011 CL63 AMG
- 2009-Present SL63 AMG
- 2011-Present SLS AMG

Product P/N: 01-156-00633-5

Phone 877-WEISTEC Fax 888-516-8219

[www.weistec.com](http://www.weistec.com)

# **WEISTEC M156/M159 ARP Camshaft Cap Bolts**

Thank you for your purchase of the Weistec M156/M159 ARP Camshaft Cap Bolts for the Mercedes AMG 63 with the 6.3L motor. Please follow all directions, and keep a clean work space when commencing installation.

## **Tools Required**

- 3/8" Drive 8mm 12 point socket
- 3/8" Drive Ratchet
- 6" Long 3/8" Drive Extension
- Torque Wrench

## I. ARP Camshaft Cap Bolt Install

1. Ensure that rotating assembly is at 40 TDC and Camshafts are in the proper orientation per Mercedes Specifications
2. Ensure that all cam caps are in the proper position and orientation. This should have been noted before disassembly of the engine.
3. Screw in ARP Cam Cap Bolts in the order shown in the diagram below (Use the 4 longer ARP Cam Cap Bolts in spots marked 7 and 8 on the bank 1 cylinder head) until the bolts are hand tight.

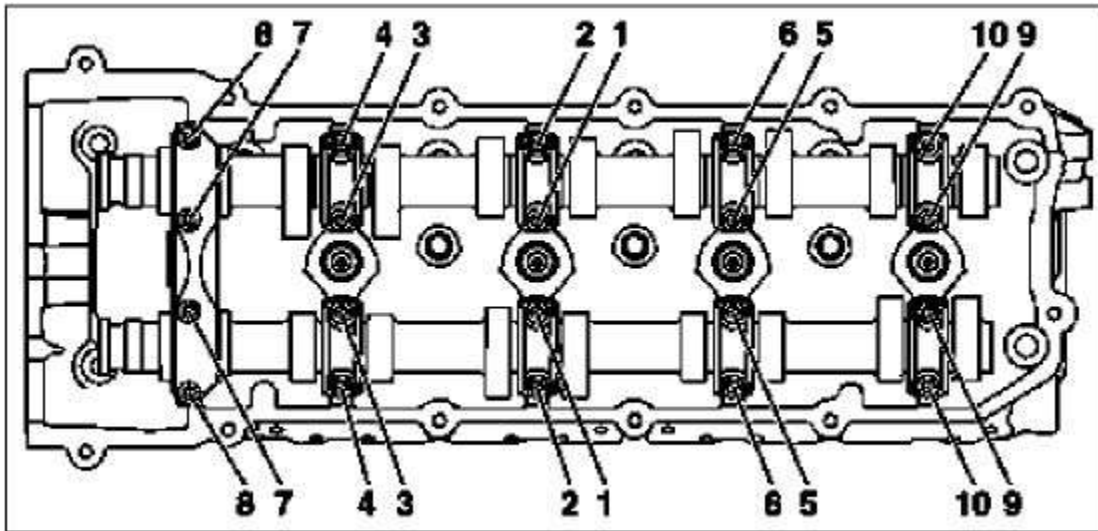

4. Slowly tighten each bolt in small increments in the tightening order until each bolt is tightened to 13 ftlbs (17.5nm)
5. Proceed with engine assembly

**Please be aware of any debris or foreign material that may fall inside cylinder head. This can damage engine parts.**