

INSTALL INSTRUCTIONS

Part #s 41844, 41844-D

Banks Ram-Air® Intake System
2018-2021 Jeep JL Wrangler 2.0L

Please read through the following instructions thoroughly before starting your installation. If you have any questions please visit our [Support Page](#).



Tools required:

8mm or 5/16" nut driver or flat end screwdriver
Phillips screwdriver
10mm socket and ratchet or wrench
Clip pry/remove tool
Longnose pliers

General Assembly

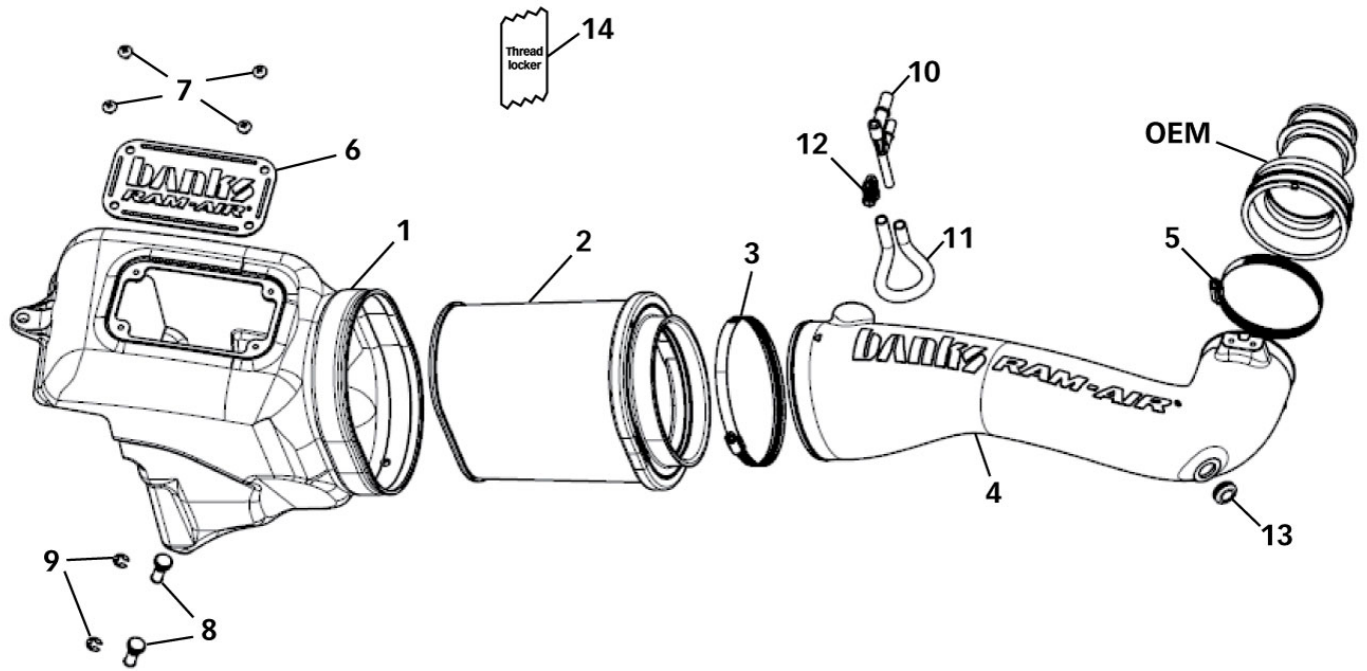

★ REVIEWS

Item	Description	Part #	Qty.
1	Housing	41845	1
2	Filter	41848	1
3	Hose Clamp #104	92904	1
4	Tube	41847	1
5	Hose Clamp #72, 1/2" Wide	92890	1
6	Window	41788	1
7	Machine Screw, 1/4-20 X 3/8	91128	4
8	Mounting Peg	92153	2
9	E-Clip, 3/8	91701	2
10	Vacuum Manifold	41847-08	1
11	Hose, 3/8" ID	94136	1
12	Barbed Hose Elbow	92042	1
13	Grommet, Temp Sensor	93650	1
14	Threadlocker, Blue .5MI	90001	1

Bill of Materials

Use caution when working in the engine compartment. Make sure the engine has been OFF for several hours and cool. Some components from the stock air intake system will remain in service. Take caution when removing stock components.

Section 2: Removal of the factory intake system



1. Remove the IAT sensor. Pull the locking clip towards you and twist counter-clockwise about 45 degrees until it stops rotating.



2. Unhook the two clips securing the IAT harness to the factory

intake tube. Pull the sensor and harness out of the way. Wrap in a shop towel to avoid any damage to the sensor.



3. Remove the two bolts holding the vapor pressure sensor bracket, using a 10mm socket.



4. Cut off the plastic tie that holds the wiring harness to the OEM intake tube.



5. Using a 10mm socket, remove the three bolts holding the OEM intake system.

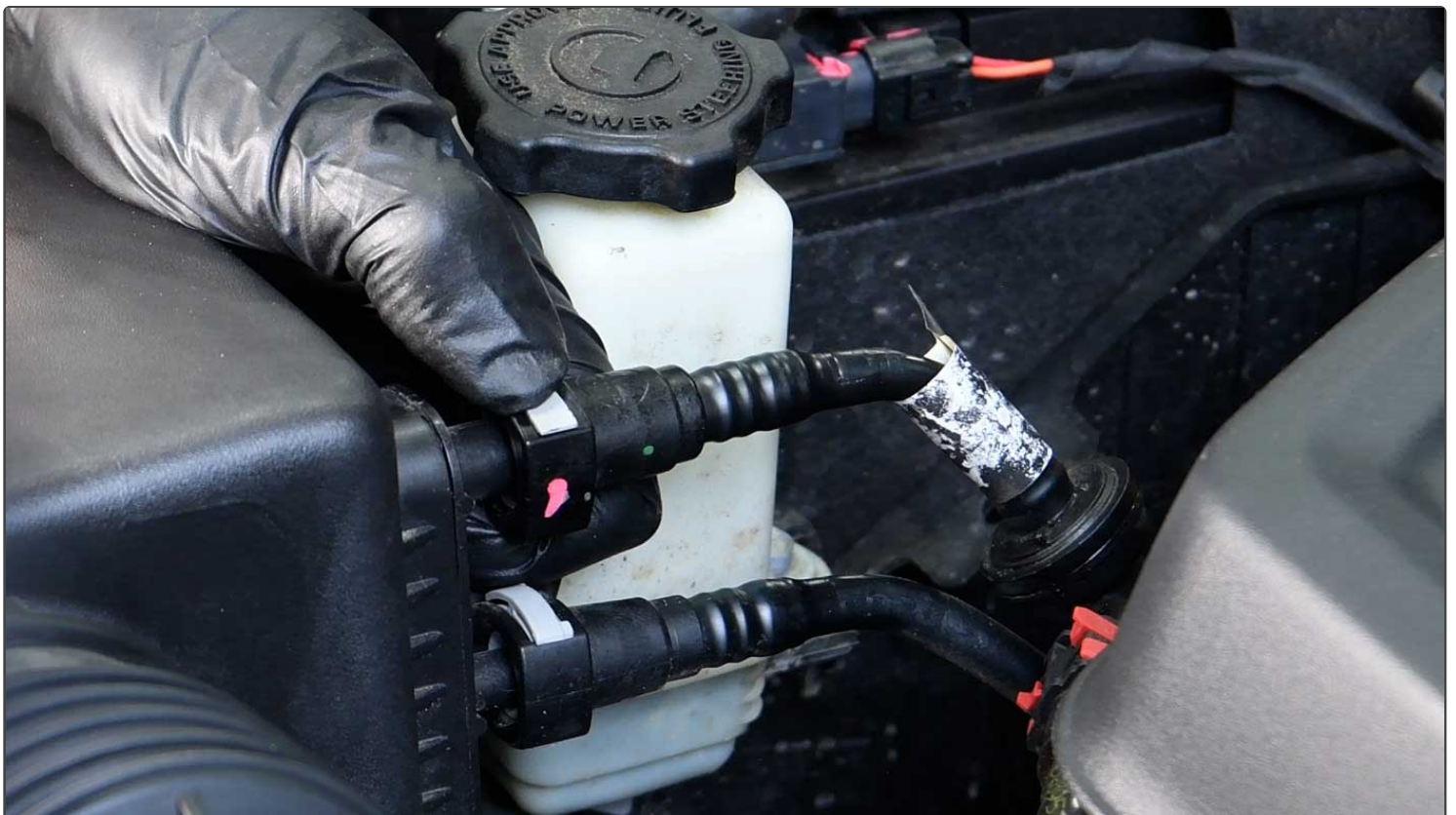

6. Remove the two plastic lines from the air filter housing by

pressing the grey tabs and pulling away from the housing.

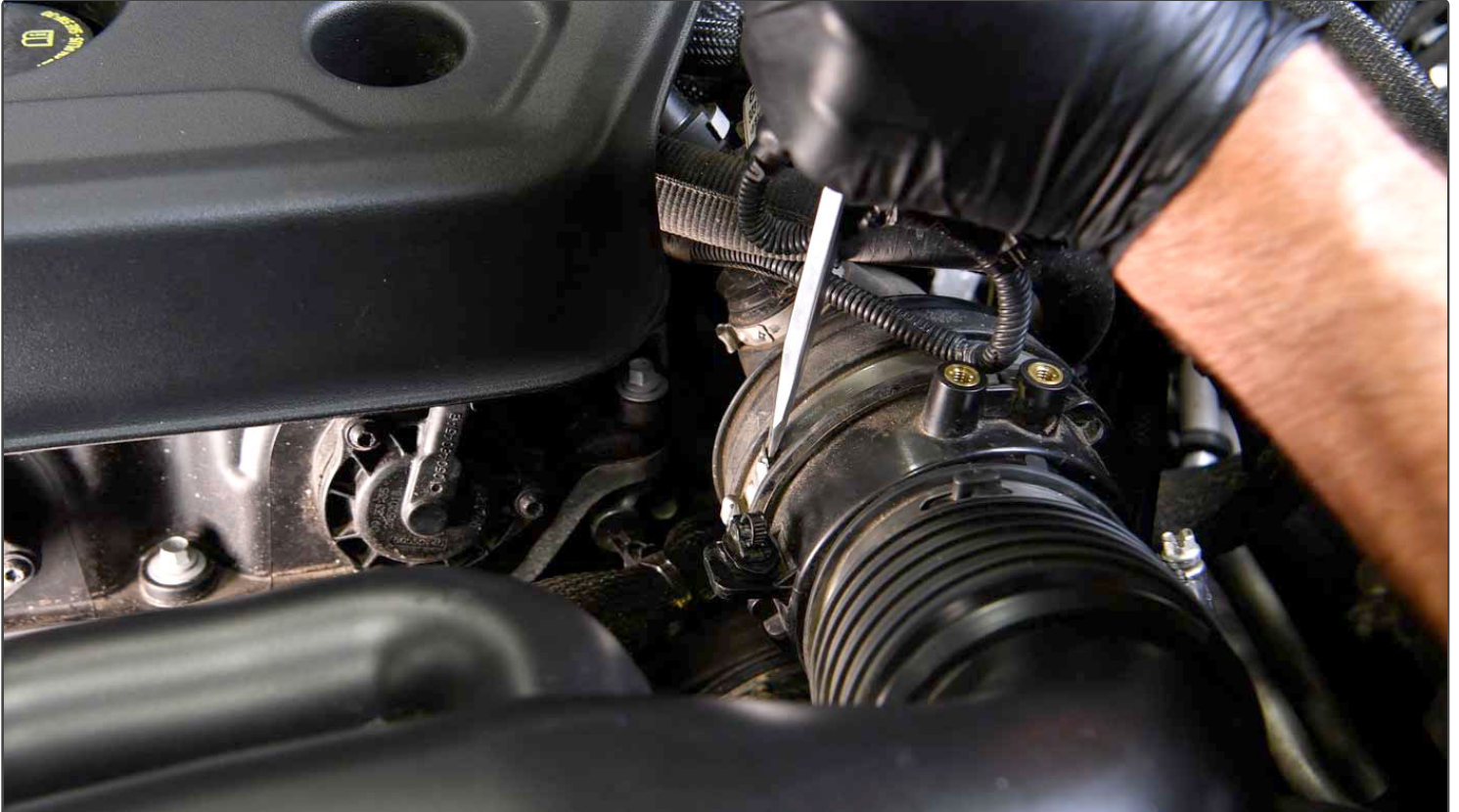

7. Remove the clamp that retains the factory air intake tube to the turbo inlet duct.

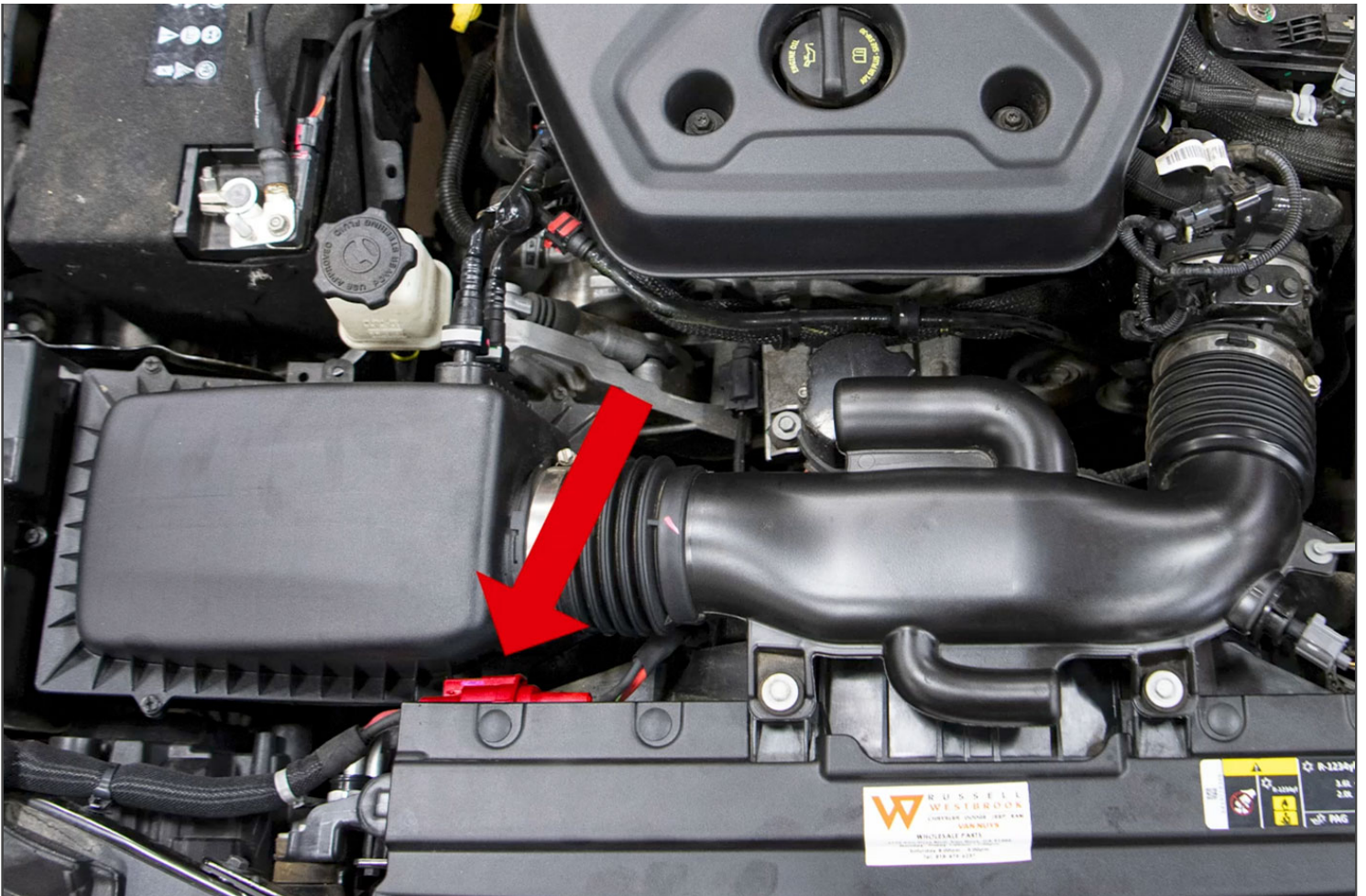

NOTE: Before removing the entire assembly, take note of the sensor connection highlighted in the photo.

IMPORTANT: Be careful not to break the clip that holds the connector in place.



8. Begin removing the assembly by sliding the tube out of the turbo inlet.

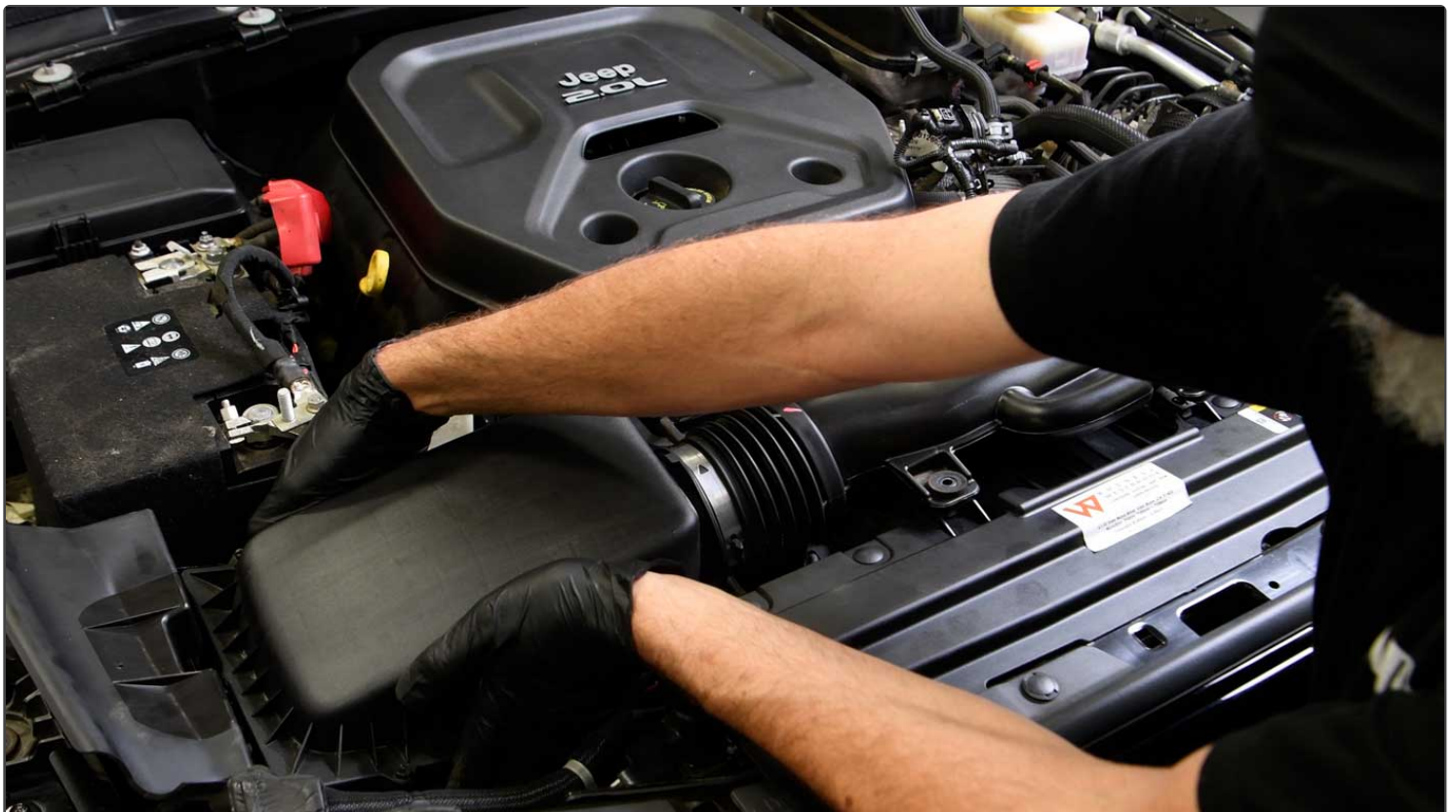

9. Grab the airbox assembly with both hands and pull up until you

feel a pop. Pull the assembly out of the engine bay.

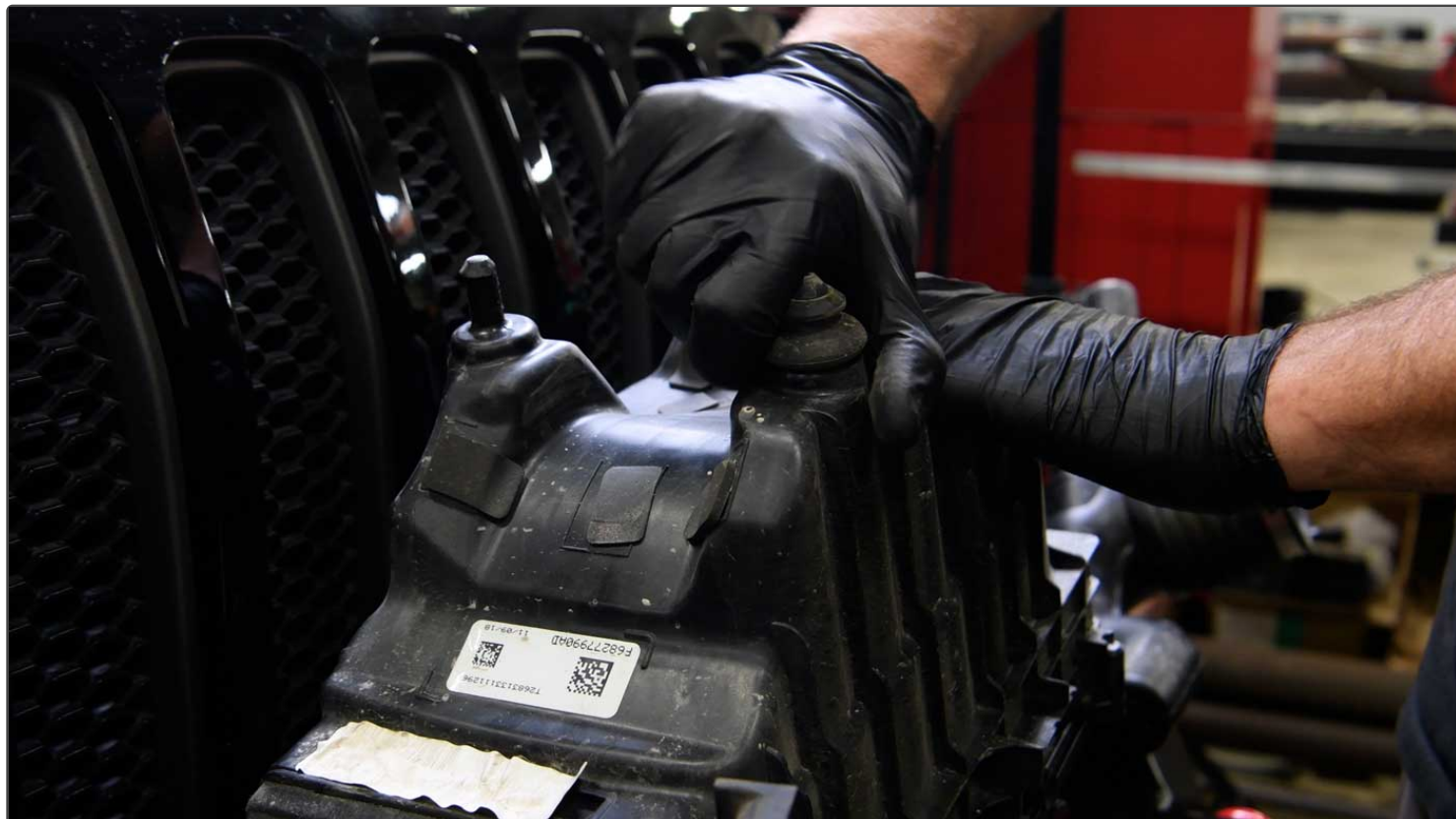

10. Before installing your new Banks Ram-Air kit, remove the rubber grommets from the factory airbox and replace them into the engine bay.



NOTE: It's very important that you install the grommets into the engine bay and NOT onto the Banks airbox.



11. Slide one aluminum peg through ^{★REVIEWS}one hole and secure it with

the retaining clip using needle nose pliers. Repeat for the other peg.

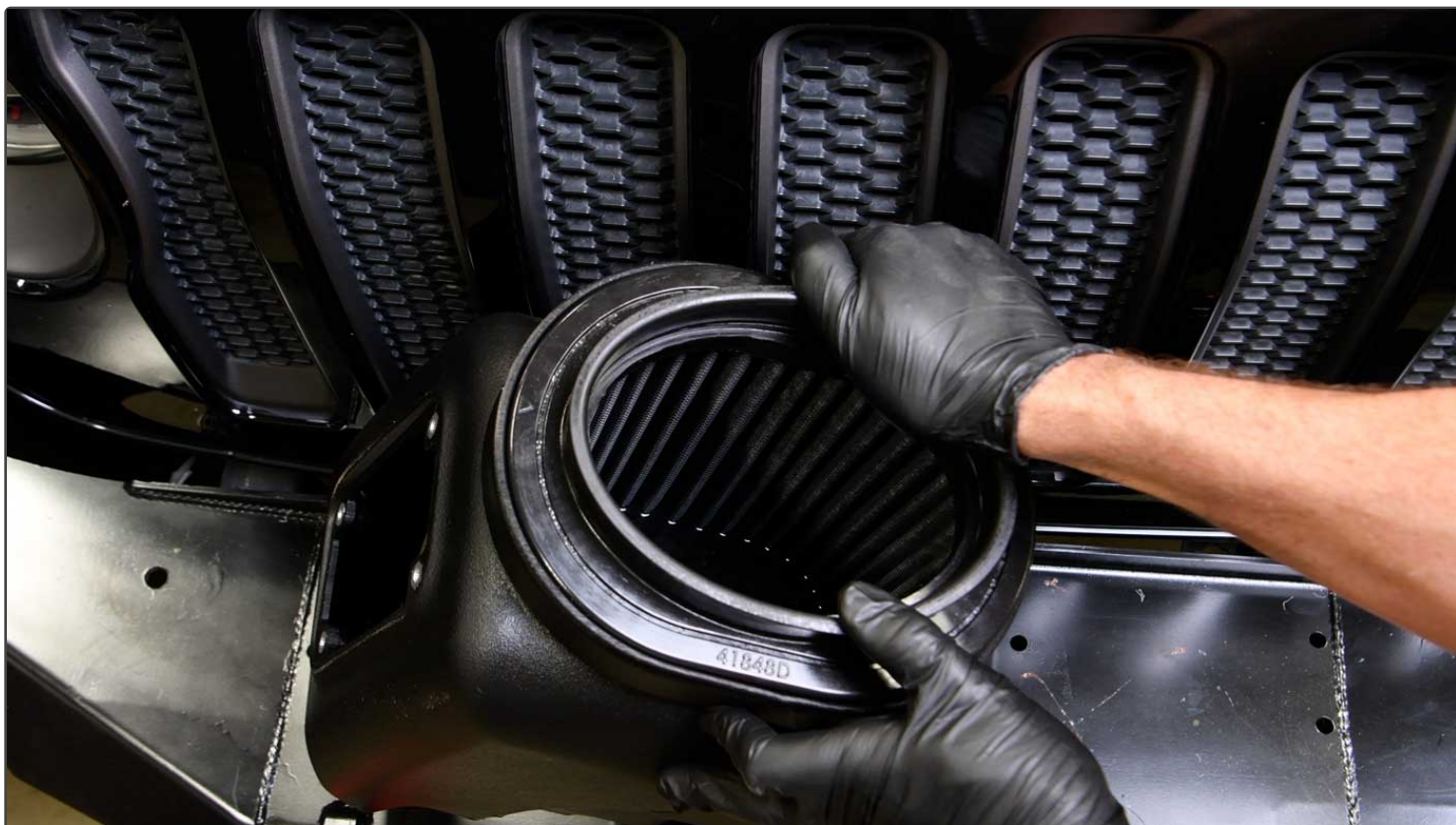

12. Install the Banks air filter into the Banks airbox and make sure the arrow on the filter is on top.

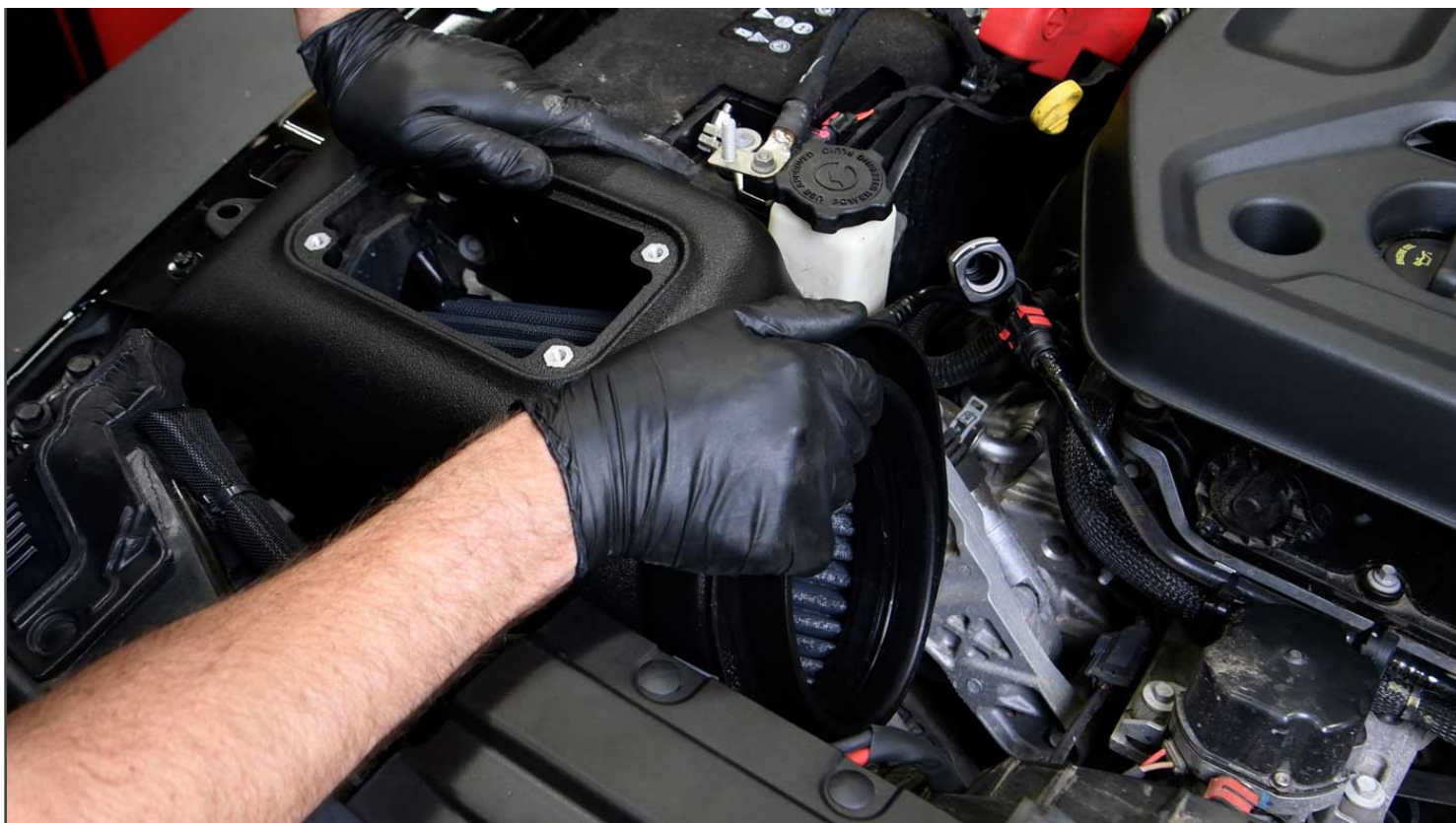

13. Install the Banks Ram-Air box into the engine bay by pressing down until it pops into the rubber grommets.



14. Secure the Banks Ram-Air box to the sidewall by using the ★ REVIEWS

factory bolt and a 10mm socket.



15. Slide the supplied hose onto the vacuum manifold.



16. Take the supplied plastic barbed hose elbow and thread it into the Banks intake tube. The barbed end should be at the 6 o'clock position.



17. Once the fitting is installed, connect the open end of the hose to the fitting. Make sure you can make a loop with the hose, as shown.

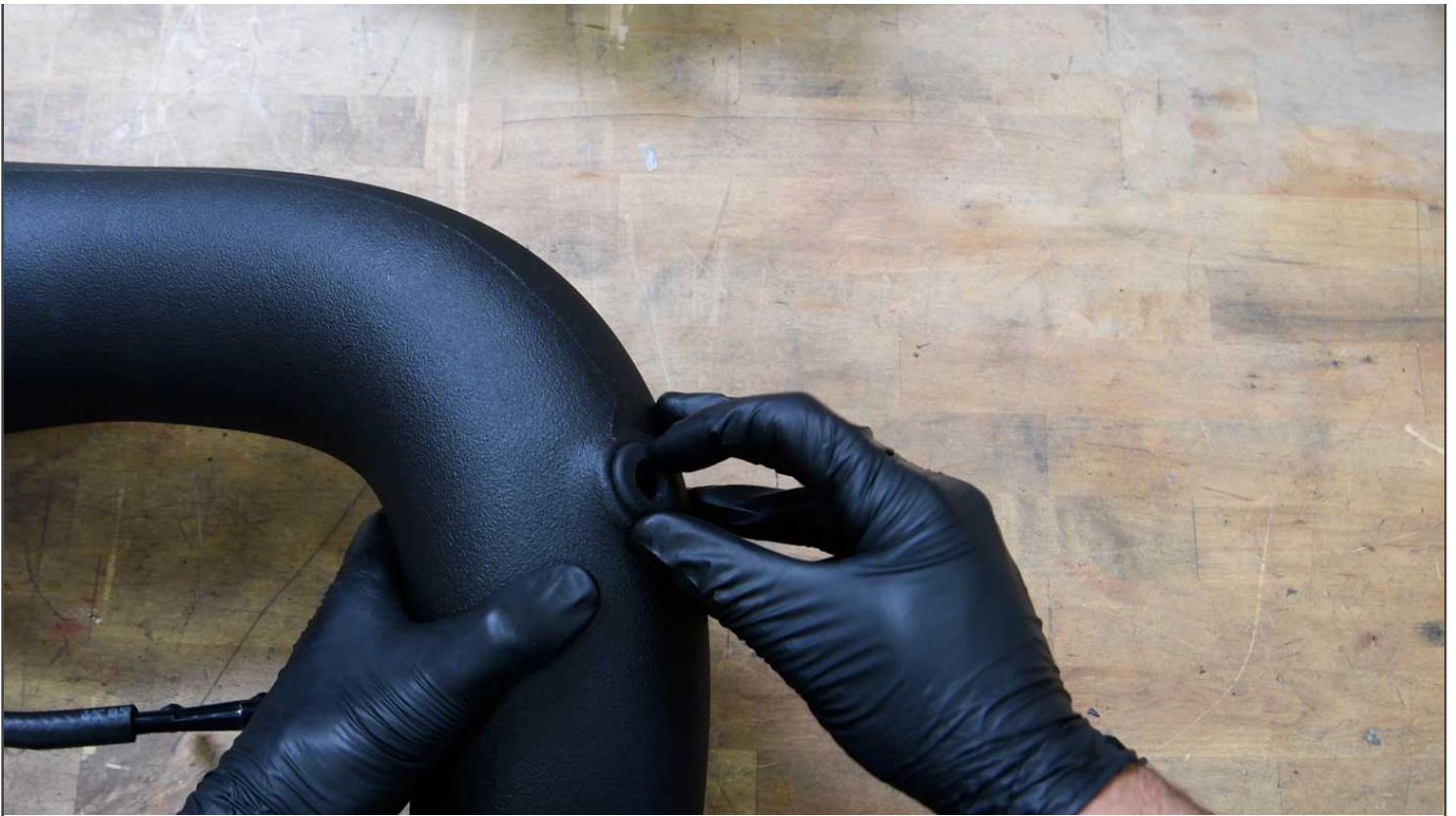

18. Install the rubber grommet for the IAT sensor onto the intake tube.



19. Place the larger supplied hose clamp onto the filter.



20. Place the smaller hose clamp over the factory turbo inlet duct.



★ REVIEWS

21. Install the Banks intake tube by first inserting the large end into the filter and then the smaller end into the OEM turbo inlet duct. Align the duct to the indent on the tube. Align the arrows on the tube and filter. Tighten both clamps.



22. Reinstall the vapor pressure sensor bracket with the factory bolts using a 10mm socket.



23. Insert the IAT sensor into the rubber grommet.



24. Reinstall the two plastic tubes into the vacuum manifold by pushing until you hear a click.

★ REVIEWS



25. Install the clear Banks Ram-Air window using the supplied screws and thread locker.

CARB EO Label Placement

★ REVIEWS

Vehicle CARB EO Label Placement

locations

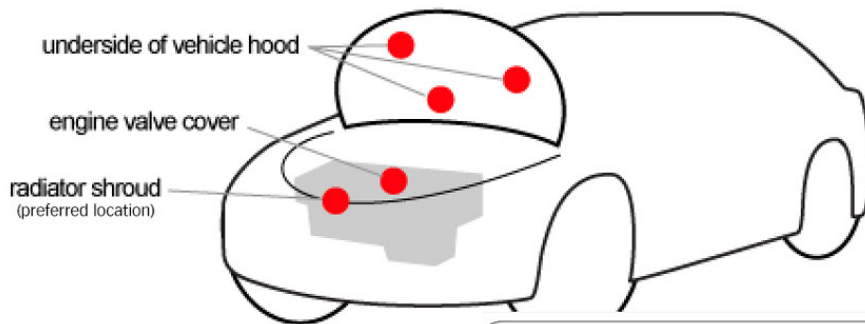

sample label

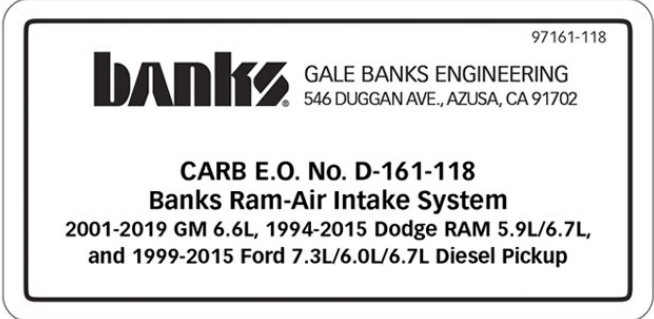

CARB EO Label

For smog check purposes, affix the CARB E.O. Label on a visible location under the hood.



Label Placement

Banks recommends using the radiator shroud location.

★ REVIEWS

Congratulations!

You have successfully installed your new Banks Ram-Air Intake. Please see air filter maintenance instructions below.

Section 4: Filter Maintenance

[Oiled Filter Cleaning - Show](#)

[Dry Filter Cleaning - Show](#)

[97702 Derringer for 2020-2021 GM L5P →](#)

👍 You May Also Like

Derringer Installation

FILTER CLEANING

Frequently Asked Questions: Ram-Air Intakes

NEED HELP? Call **800-601-8072** from 7am-5pm Pacific.

Latest Videos

[View All](#)

📺 Subscribe to Banks Power channel

How Not To Drive A 1,400HP Trans-Am | Speed School Podcast Ep 2

World's Fastest Production Car | Speed School Podcast with Gale Banks Ep 1

Pics or it didn't happen!



bankspower
Turbochargin' since '58. #bankspower
#banksbuilt #houseofhorsepower
#galebanks



[Load More...](#)

[Follow us on Instagram](#)

★ Popular

🕒 Recent



6.6L Crate Engine



Derringer L5P Tuner for the 2017-2019 Duramax: Real Power is here!



Owners Manuals



Changing Times: GM's Push To Make L5P Duramax Un-Crackable

★ REVIEWS

Questions?
Ask us anything.
Power... Durability...
Efficiency! You want it, we
have it!! Nobody knows it
better than us.

Contact Us

Call 800-601-8072
Mon-Fri 7am-5pm
Pacific Time

Looking to buy Banks?



Privacy Policy

Send us a message

Fax 626-691-2122

Sitemap

546 S Duggan Avenue
Azusa, CA 91702

Map/Directions

Shop online 24/7

or visit our PowerHouse

I've raced & built engines since '56. Since '65 my favorite performance tool has been the turbocharger, I boosted my first diesel in '78, set a few records too!

Our mission is to improve performance, durability and the driving experience, all without compromising emissions requirements.

Gas & Diesel Performance for Cars, Trucks, Jeeps and Motorhomes
Copyright © 2022 Gale Banks Engineering. All rights reserved.

