

2017+ Camaro ZL1
Intercooled System/
Competition Race Kit
Installation Guide



The **ULTIMATE** Power Adder™

Accessible Technologies, Inc.
14801 W. 114th Terrace
Lenexa, KS 66215
Phone: 913.338.2886
Fax: 913.338.2879
techserv@procharger.com

All rights reserved. Accessible Technologies Inc. hereby grants permission to use and reproduce this document for personal use, provided that all copyright information be retained. Reproduction of this document for unauthorized commercial use is strictly prohibited.

Information in this document is subject to change without notice.

ProCharger is a registered trademark and The Intercooled Supercharging Experts![™] and Designed to Blow Away the Competition[™] are trademarks of Accessible Technologies, Inc. and may not be used without express permission.

You should also have the following gauges available to properly check the finished installation and monitor your vehicle's performance (especially for testing):

- Manifold Boost Pressure Gauge
- Fuel Pressure Gauge
- Wide Band Oxygen Sensor and Gauge

Gauges should be of a type that can be read from the cockpit while performing a wide-open throttle road test. Cockpit or hood-mounted gauges are preferable. In order to obtain usable readings, the gauges should measure pressure at the intake manifold and fuel rail. IF VEHICLE DOES NOT MAINTAIN PROPER FUEL PRESSURE (50-65 PSI), DECREASE THROTTLE APPLICATION IMMEDIATELY. In some cases, extra vehicle modifications can strain the stock fuel pump. If your vehicle has difficulty retaining adequate fuel pressure, contact ATI ProCharger about the availability of an upgraded fuel system.

The engine on which the ProCharger[®] is to be installed should retain the factory compression ratio. If it has been modified in any way, please consult ProCharger staff before proceeding with the installation. This supercharger system is intended for use on STOCK, strong, well-maintained engines/transmissions. Installation on a worn or troublesome powertrain should be reconsidered. ATI PROCHARGER WILL NOT BE HELD RESPONSIBLE FOR DAMAGE TO A VEHICLE'S POWERTRAIN. ATI ProCharger is not responsible for ECM tuning/programming on non-stock vehicles. ATI PROCHARGER recommends verifying that your vehicle has current ECM updates from the vehicle manufacturer before installation.

For best performance and reliability, always use premium grade fuel (91 octane or higher) and listen closely for signs of detonation, which might sound like ball bearings rolling around in a tin can. IF DETONATION SHOULD OCCUR, OR IF YOU ARE UNSURE WHETHER WHAT YOU'RE HEARING IS DETONATION, DECREASE THROTTLE APPLICATION IMMEDIATELY and please consult ATI ProCharger staff. Detonation should not be an issue with a properly installed intercooled supercharger system, though OEM factory-shipped engine and parts inconsistencies are possible on any vehicle.

INTRODUCTION

Congratulations on purchasing your ProCharger® 2017+ Camaro ZL1 Intercooled System. Read this entire manual before you attempt to install your ProCharger kit. It is imperative that you follow all of the instructions in the order they appear in this installation guide. If you have any questions regarding any aspect of this installation, call us at (913) 338-2886.

For best results, we recommend reviewing the installation instructions beforehand, and following the installation instructions closely and in sequence. A detailed packing list has been provided to assist you in identifying the components of your ProCharger system.

 **Tech Tip:** *Installing spark plugs that are one heat range colder than stock and gapping your plugs to .035" is recommended.*

 **Warning:** *Read and understand all safety precautions in this manual before installation. Failure to comply with instructions in this manual could result in personal injury, property damage, and/or voiding your warranty.*

Required Tools and Supplies

- Open End Wrench Set (standard & metric)
- 3/8" & 1/2" Socket Sets (standard & metric)
- 3/8" Hex Bit Set (standard & metric)
- 7mm & 8mm nut driver
- T15 & T45 Torx bits
- Pry Bar
- 1/2" Breaker Bar
- Flat & Phillips Screwdrivers
- Plier Set
- Hose cutter
- Silicone Gasket Maker
- Air Saw or Hack Saw
- 1/2" Drill Bit and Drill

 **Warning:** *Your supercharged Camaro must always be run on 91 octane or better gas. The best way to insure this is to run the tank near empty (below 1/4) and fill with 91 octane for several tanks prior to installing the supercharger.*

TABLE OF CONTENTS

Introduction	i
Table of Contents.....	ii
Getting Started.....	1
Factory Supercharger Removal.....	11
Crank Pulley	17
ProCharger Installation	21
Intake Manifold.....	24
Intercooler Prep.....	29
Component Relocation	31
Air to Water Intercooler.....	32
Intercooler Coolant Routing	40
Air to Air Intercooler.....	43
Final Assembly.....	49
Operation and Maintenance	52
Limited Warranty	54

GETTING STARTED



Completion of this section will configure the vehicle for system installation:

(A) Factory Air Filter Box

(B) Mass Airflow (MAF) sensor

(C) Factory Inlet Tube

! *Read and understand all safety precautions in this manual before installation. Failure to comply with instructions in this manual could result in personal injury, property damage, and/or voiding your warranty.*

Getting Started

- 1 Use a 22mm socket to break the lug nuts loose on the front wheels, but do not remove.
- 2 Ensure the parking brake is fully engaged. Raise the front of the vehicle. Support with jack stands.
- 3 Remove the front wheels from the vehicle.



Remove Front Wheels

- 4 Use a T15 torx to remove the (8) screws at the top of the front fascia.
- 5 Remove the (2) plastic push clips on the top of the fascia.



Remove Screws and Push Clips

- 6 Remove the plastic trim on top of the fascia by pulling up to unclip them.



Remove the Plastic Trim

- 7** Underneath the car, use a 7mm and 10mm to remove the (13) screws, (6) bolts, and (1) plastic push clip holding the plastic splash panel. Remove the panel.
- 8** Remove the remaining (12) screws on the bottom of the fascia.
- 9** Use a T15 torx to remove the (4) screws holding the wheel liner to the fascia and fender. Repeat for other side.



Plastic Splash Panel Screws and Bolts



Remove Wheel Liner Screws

- 10** Pull the wheel liner back to gain access to fascia screw. Use a 7mm to remove the (1) screw going vertically into the fender. Repeat for other side.



Screw Behind Wheel Liner

Getting Started

- 11 Use a 7mm to remove the (4) screws going horizontally into the fender. Repeat for the other side.



Screws Behind Wheel Liner
(Lower Two Shown)

- 12 Behind the driver's side wheel liner, locate and disconnect the fascia's wiring harness connector. Unclip the harness from the body to allow the fascia to be removed.



Wiring Harness Connector

- 13 Pull outward on the fascia where it attaches to the fenders. Pull fascia straight back to remove.



Fascia Removed

- 15 Locate the PCV line that runs from the air inlet tube to the PCV reservoir near the passenger's side cylinder head. Squeeze the connectors to release them. Remove the line.

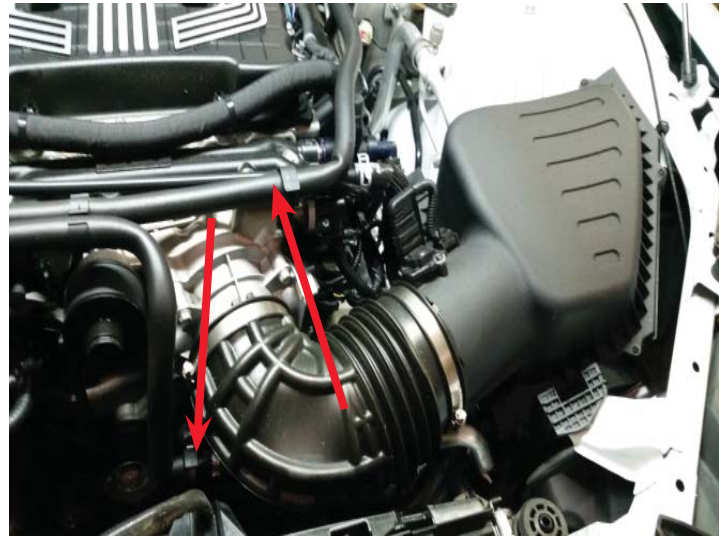

Disconnect Hoses from Inlet Tube

- 16 Disconnect the MAF (Mass Air Flow) sensor.

- 17 Use an 8mm to loosen the hose clamp on the throttle body. Pull up on the airbox to remove.



Air Inlet Removed

Getting Started

- 18** Use a 10mm to remove the (4) bolts and push pin on passenger's side holding the radiator cover. Remove cover.



Remove Radiator Cover Bolts

- 19** Use a flat screw driver to remove the (3) plastic push clips that go through the transmission cooler bracket into the brake duct. Repeat for other side.



Brake Duct Push Clips

- 20** Remove the (5) plastic push clips that hold the driver's side auxiliary heat exchanger scoop. Remove the driver's scoop.



Radiator Scoop Push Clips

- 21** Remove the plastic push clip that goes from the top of the brake duct vertically into the frame rail. Remove the push clip on the back side. Remove both driver's and passenger's side brake ducts.

- 22** Use a 7mm to remove the (4) screws holding the driver's side headlight. Pull headlight forward and unplug the (2) electrical connectors. Remove headlight. Repeat these steps for the passenger's headlight.



Remove Headlight Screws

- 23** Use a flat screwdriver to remove the (3) plastic push clips holding the driver's side headlight shroud. Remove the shroud.



Remove Headlight Shroud Clips

- 24** Remove the (3) plastic push clips holding the plastic panel next to the passenger's side headlight. Remove the panel.



Remove Plastic Panel (Passenger's Side)

Getting Started

25 Use a flat screwdriver to remove additional plastic push clips holding the plastic covers on the driver's side. Remove the covers.

26 Use a 10mm to remove the core support braces.



Remove Plastic Covers (Driver's Side)

27 Use a 10mm to remove the (2) bolts that hold the transmission cooler bracket to the bottom side of the bumper.



Transmission Bracket Bolt

28 Underneath the transmission cooler, unclip the transmission line from the plastic air shroud.

29 Remove the ambient air temperature sensor from the passenger's side of the shroud.

30 Remove the air shroud.



Ambient Air Temperature Sensor

- 31 Rotate the transmission cooler down and let hang.



Transmission Cooler Dropped Down

- 32 Use a flat screwdriver to remove the plastic push clip on the bottom of the driver's side radiator/condenser plastic cover.

- 33 Use a flat screwdriver to remove the (4) metal lock tabs on the cover.

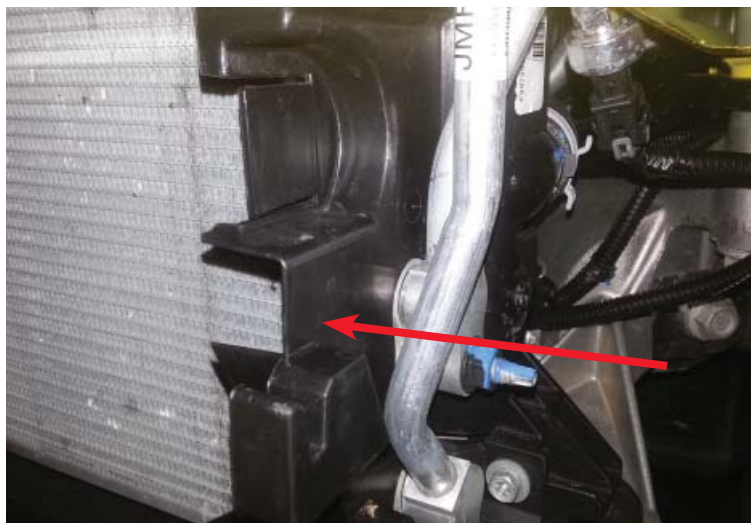

Plastic Radiator Cover (Driver's)

- 34 The cover surrounds the A/C lines. Cut the cover just above the upper A/C line connection to remove the cover from the vehicle.

- 35 Repeat these steps to remove the passenger's side plastic cover.



Plastic Radiator Cover (Passenger's)

Getting Started

- 36 Disconnect the plastic push clip from the passenger's side radiator duct going into the bumper. Disconnect all of the wiring harness connections to the bumper.
- 37 Use a 13mm to remove the (8) bumper to frame bolts to remove the bumper.



Bumper to Frame Bolts

FACTORY SUPERCHARGER REMOVAL

- 1 Place a drain pan under the heat exchanger petcock on the drivers side. Using a 3/8" drive open the drain.



Heat Exchanger Drain

- 2 Crack open the bleeder screw located behind the throttle body. Drain the Intercooler coolant.



Bleeder Screw

- 3 Unclip and disconnect the water hoses behind the throttle body. Disconnect the Vacuum hose behind the throttle body, EVAP hose, EVAP electrical connector, MAP sensor and the throttle body electrical connector.

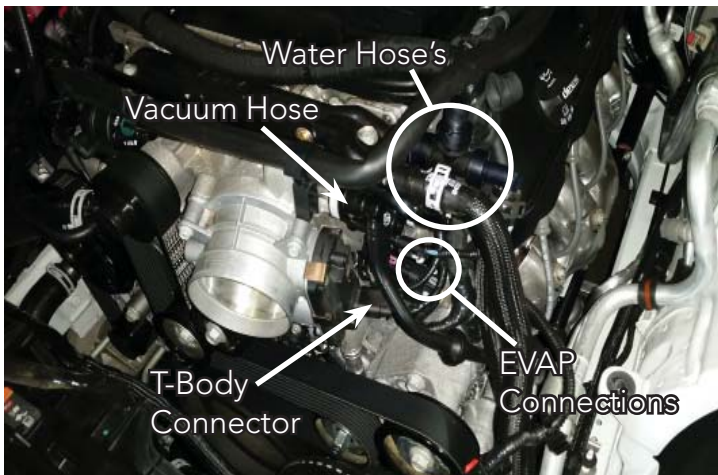

Electrical Connector / Hose Connections



Connections Disconnected

Factory Supercharger Removal

- 4 Disconnect the electrical connector at the boost bypass valve. This plug-in will not be reused, tape off the end of the connector and tuck it away, or clip the ends of the wires and tape off the bare ends.



Boost Bypass Valve Connector

- 5 Using a 15mm on the supercharger belt tensioner, rotate the tensioner counter-clockwise and remove the belt.



Supercharger Belt Tensioner

- 6 Disconnect the drivers side coil pack connections. Remove the harness from the drivers side of the supercharger and the cylinder head. Pull the disconnected harness down to the front and below the throttle body.

- 7 Using a 10mm remove (4) bolts securing the throttle body.



Drivers Side Wiring Harness Disconnected

- 8 Disconnect the map sensor connector located at the rear of the supercharger.



Rear Map Sensor

- 9 Using a 10mm remove the (20) bolts retaining the supercharger lid.



Supercharger Lid

- 10 Remove the (10) bolts retaining the supercharger to the cylinder heads with a 10mm.

- 11 Carefully remove the supercharger from the vehicle.

- 12 Remove the foam insulator pad located below the supercharger.

- 13 Cover the cylinder head ports while the supercharger is removed to keep contamination to a minimum.



Supercharger Bolts

Factory Supercharger Removal

- 14 Pry back the radiator end tank covers to access the (4) heat exchanger bolts, remove them with a 10mm.
- 15 Unhook the cooler lines from the heat exchanger.
- 16 Remove the (2) bolts securing the heat exchanger brackets to the vehicle. Repeat for the other side.



Heat Exchanger Bracket (Passenger's)

- 17 On the driver's side frame rail, use a 13mm to remove the (2) bolts attaching the radiator bracket to the frame.



Upper Aux. Heat Exchanger Bolts

- 18 Use a 10mm to remove the (2) bolts on the top of the driver's auxiliary heat exchanger bracket that holds the two halves of the bracket together.



Aux. Heat Exchanger Bracket Bolts

19 Use a 13mm to remove the bolt attaching the bottom of the bracket to the k-member.

20 Unplug hoses from the auxiliary heat exchanger and remove it from the vehicle.



Lower Aux. Heat Exchanger Bracket Bolt

21 Remove the heat exchanger hose that went from the large heat exchanger to the supercharger.

22 Use a 10mm to remove the (2) intercooler pump bracket bolts.

23 Remove the lines to the intercooler pump then unplug the wiring harness. Remove the pump from the vehicle



Intercooler Pump Bolts

24 Use a 13mm to remove the (3) supercharger belt tensioner bolts.



Tensioner Bolts

Factory Supercharger Removal

- 25** Use a 13mm to remove (2) bolts from the tensioner bracket and a 15mm to remove the remaining (2) bolts.



Tensioner Bracket Bolts (3 of 4 shown)

- 26** Remove the (2) idler pulleys shown to the right with a 15mm.



Idler Pulleys

CRANK PULLEY

- 1 Using a 15mm rotate the tensioner clockwise and remove the accessory belt.



Belt Tensioner

- 2 With a long flat blade screwdriver, pry the A/C belt up and off the top side of the A/C compressor pulley while simultaneously using a 24mm socket and ratchet on the crank bolt to rotate the crank pulley clockwise to walk the belt off the pulley.

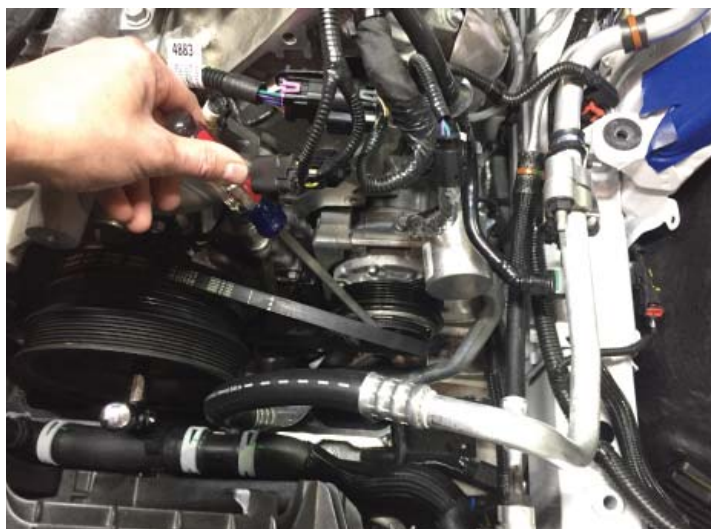

A/C Belt Removal

Crank Pulley

- 3 Separate the large radiator hose from the fan housing. Push the radiator hose down and out of the way.



Disconnect Radiator Hose From Fan

- 4 Disconnect the fan electrical connector along with the push pin that holds the connector to the shroud.

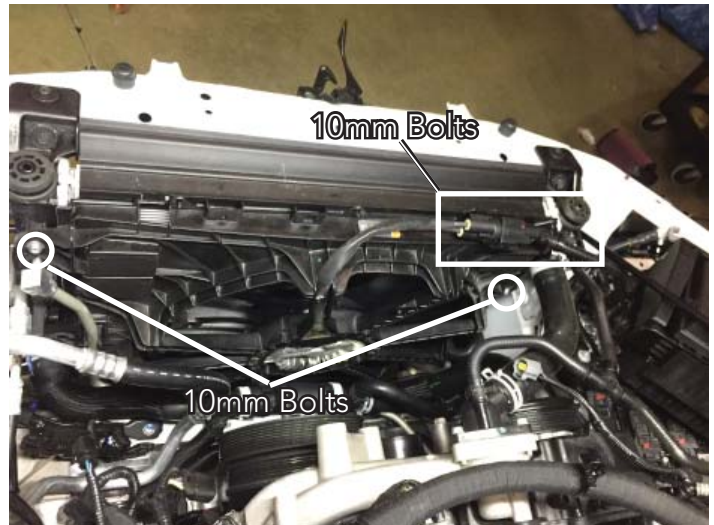

Fan Electrical Connector / Bolts

- 5 Use a 10mm to remove the (2) fan shroud bolts.

- 6 From under the vehicle remove the bottom (3) fan shroud bolts using a 7mm.



Bottom Fan Shroud Bolts

- 7 Disconnect the transmission cooler line from the radiator by removing the sliding the black cap back from the line and removing the retaining clip. Pull straight out on the line to unhook it.
- 8 Remove the fan by pulling straight up, being careful not to damage any hoses or electrical connectors along the way.



Transmission cooler line.

Manual Transmission

- 9 Put the car in 6th gear. Make sure the parking brake is fully engaged and the back tires are firmly on the ground.

Automatic Transmission

Manual skip to step 12

- 10 Underneath the car, locate the round metal access cover for the torque converter. Use a flat screw driver to remove the cover.
- 11 Use a pry bar or large flat screw driver to wedge between a torque converter bolt boss and the bellhousing.
- 12 Use a torch on the head of the crank bolt to loosen the factory sealant.
- 13 Use a 24mm and large breaker bar to remove the crank balancer bolt.



Torque Converter Access Cover



Torque Converter Bolts

Crank Pulley

- 14 Remove the factory balancer using a pulley puller.

✓ **Tech Tip:** Requires ATI balancer part.# 918856 which is not included in the system.

- 15 Install the ATI balancer following the manufacturers instructions.

- 16 Apply a bead of silicone around the supplied crankshaft bolt head and washer. Insert the bolt through the balancer into the crankshaft. Thread the bolt in until hand tight.

- 17 Use a 24mm and a breaker bar to tighten the crank bolt.

- 18 Install the supplied crank pulley using the supplies 3/8" bolts and washers. Use red thread locker on the threads.

- 19 Re-install the A/C belt using the reverse procedure of taking the belt off. Re-install the factory accessory belt.

- 20 Re-install the fan and all connections.

- 21 Do not reconnect the radiator hose to its original location on the fan. Slide the plastic ring towards the passenger's side and out of the way. Use a zip tie around the fan structure to securely hold the radiator hose away from the crank pulley. Ensure the fan blades will not contact the zip tie.



ATI Balancer Installed



Crank Pulley Installed



Zip Tie Radiator Hose to Fan

PROCHARGER INSTALLATION

- 1 Disconnect the wiring harness and plastic air line from the bracket holding the A/C line to the frame rail.
- 2 Use a 10mm to remove the nut holding the bracket to the frame rail. Slide the bracket off the A/C line.



Factory A/C Line Bracket

- 3 Located in the radiator relocation bag, assemble the new A/C line bracket by sliding the supplied panel nut over the end of the bracket. The rubber loop clamp will be attached as shown, using the supplied M6 bolt.



Assembled A/C Line Bracket

- 4 Attach the rubber loop clamp around the A/C line. Run the supplied bolt through the loop clamp and into the panel nut on the new A/C bracket. Mount the bracket to the factory location and reinstall the factory nut.



Factory A/C Line Bracket

ProCharger Installation

- 5 Locate the bracket bag. Use a 3/4" wrench to remove the idler pulley.
- 6 Use a 13mm to loosen the connector bracket on the cylinder head. Remove the wiring harness attachment at the head.
- 7 Assemble the main bracket as shown. Note that the (3) spacers are all the same length, but (1) has a smaller inside diameter for the smaller diameter 8mm bolt. The 8mm bolt goes in the uppermost mounting hole. Mount the bracket to the engine. Tighten the bolts using 17mm and 13mm sockets. Retighten the electrical connector bracket.
- 8 Reinstall the idler pulley into the lower threaded hole. Tighten with a 3/4" wrench.

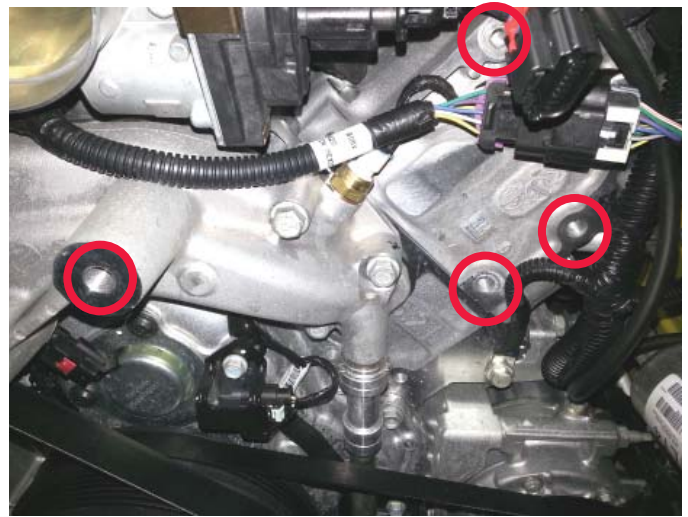

Bracket Mounting Holes

✓ **Tech Tip:** To gain hood clearance be sure the bracket is as low as possible before fully tightening the bolts.

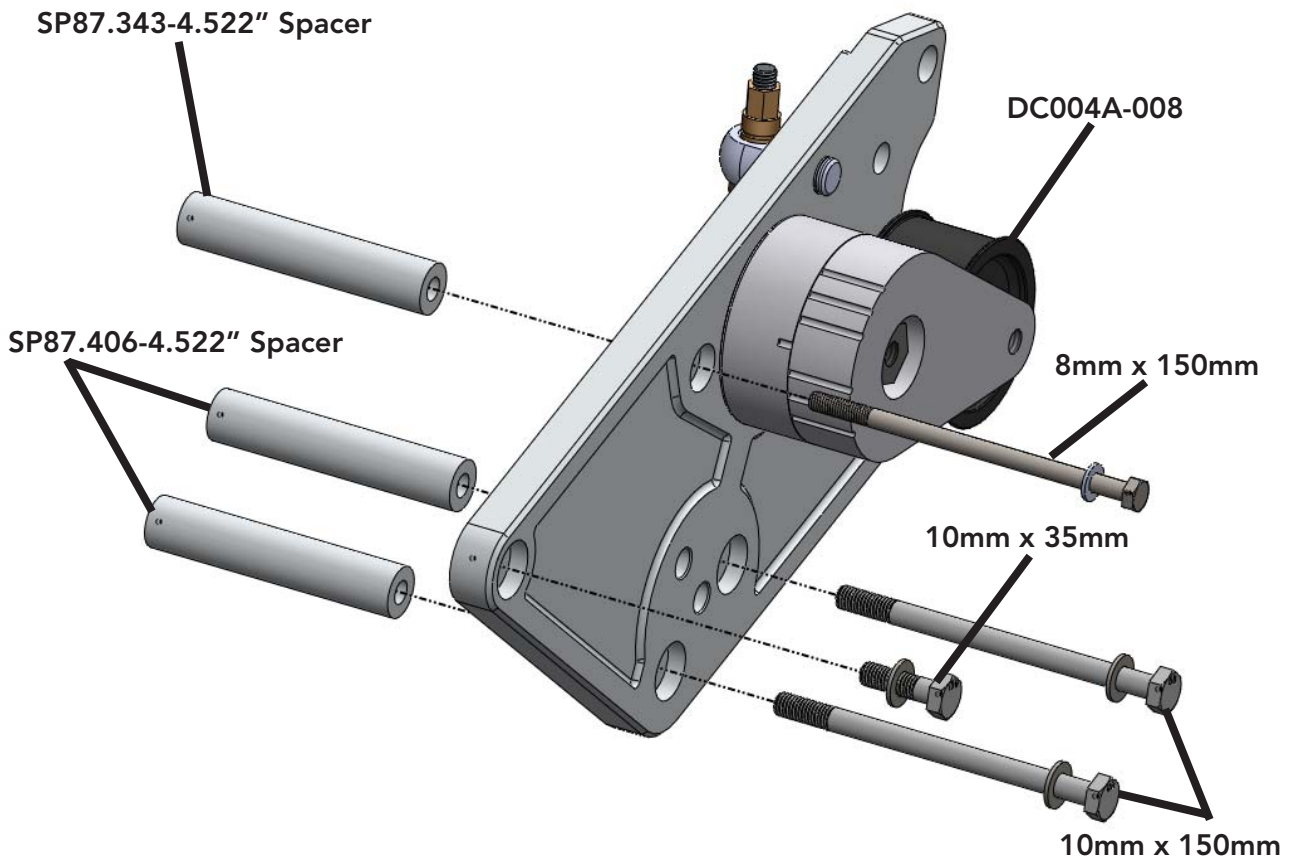

Main Bracket Assembly

- 9 Install the 90° fitting onto the bottom of the supercharger's drain fitting. Install the oil drain line onto the 90° fitting. Fill the supercharger with the supplied blower oil.
- 10 Mount the ProCharger onto the main bracket using the provided 5/16" and 3/8" SHCS's. Tighten the fasteners using 1/4" and 5/16" allen keys.



Supercharger Mounted

✓ **Tech Tip:** The tensioner will have to be moved up and down to gain clearance for the supercharger bolts. This can be done by turning the brass tensioner collar with a 1/2" socket.

- 11 Use a 3/4" to loosen the tensioner pivot bolt. Use a 9/16" to loosen the jackscrew mounting bolt just enough for the tensioner to pivot. Using a 1/2", turn the brass collar clockwise to rotate the tensioner all the way up.

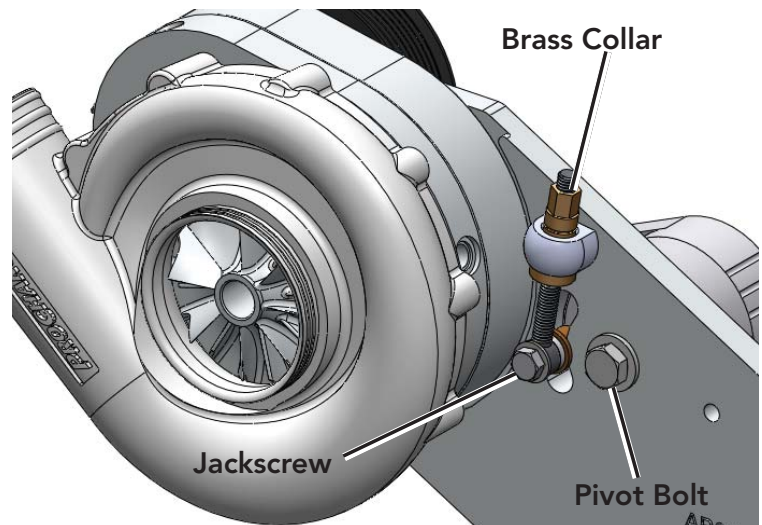

Tensioner Assembly

- 12 Install the supplied supercharger belt.

- 13 Tighten the belt by rotating the brass collar counterclockwise until the first set of etched marks on the tensioner body align. Use a 3/4" to tighten the pivot bolt. Ensure the bolt is tight enough to hold the tensioner from rotating. Turn the brass collar clockwise to release tension on the jackscrew. Use a 9/16" to tighten the jackscrew mounting bolt.

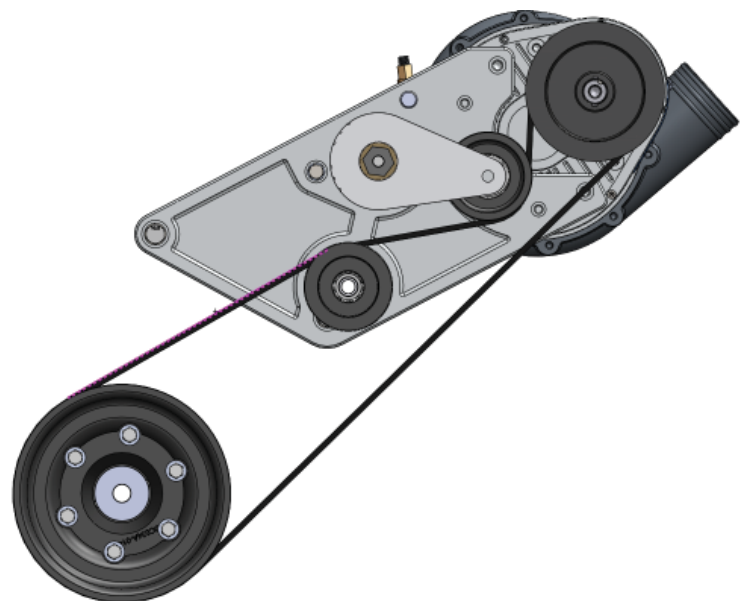

Belt Routing

INTAKE MANIFOLD

- 1** Remove the intake port o-rings from the factory supercharger and install them into the intake manifold.
- 2** Remove the front and rear MAP sensors and the EVAP solenoid from the factory supercharger. Inspect the o-rings and apply a small amount of oil to the o-rings. Use a 10mm to install the front and rear MAPs onto the intake manifold using the supplied M6x20mm bolts, and the EVAP using the supplied M6x25mm bolt.
- 3** Apply thread sealer to the supplied 3/8 NPT x 3/8 barb fitting and install it into the port on the bottom side of the intake manifold. Point the barb end towards the throttle body.
- 4** Remove the throttle body gasket from the factory supercharger. Install the gasket into the intake manifold.
- 5** Apply thread sealer to the supplied 90° 1/8 NPT x 3/8 barb fitting. Use pliers to hold the supplied adapter fitting around the larger diameter. Do not damage the surface of the smaller outside diameter. Thread the barb fitting into the adapter. Tighten only by hand.



EVAP, MAP and Throttle Body O-ring Installed

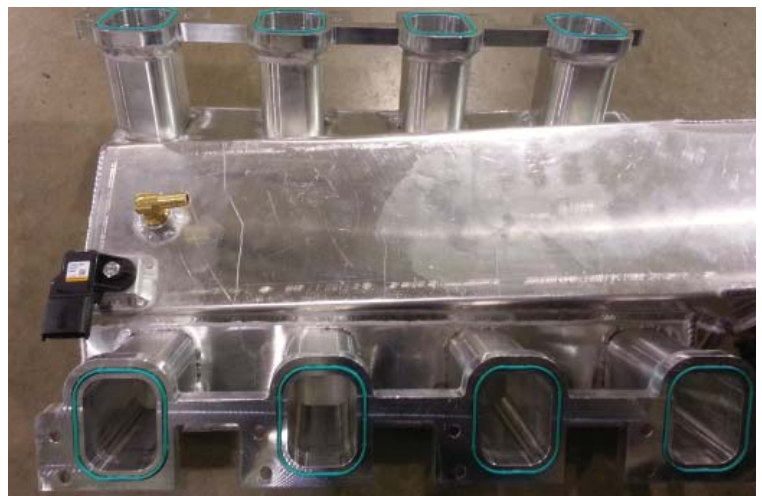

Rear MAP, O-rings, and Barb Fitting Installed



Adapter Fitting Installed on Barb Fitting

- 6 Remove the steel fitting on the top of the valley cover. Use a small flat screw driver and hammer to work around the fitting and pry it up evenly.
- 7 With the barb pointed towards the rear of the car, install the fitting and adapter into the port that the factory steel fitting was removed from. Use a hammer to lightly tap the fitting until the larger diameter is flush with the valley cover.

✓ **Tech Tip:** If the supplied valley cover fitting is too loose in the bore it is acceptable to use silicone or a Loctite 545 on the fitting to secure it.



Barb Fitting Installed In Valley Cover

- 8 Assemble the vacuum manifold with a straight 3/8" barb fitting on each end. Plug (2) of the 1/8" ports with the 1/8" brass plugs. Install the pushlock fitting in the remaining 1/8" port. If installing an aftermarket boost gauge, replace (1) of the plugs with a supplied 1/8" barb fitting.



Vacuum Manifold Assembled

- 9 Attach supplied 2" long section of 3/8 rubber hose to the fitting in the valley cover. Secure with a #04 hose clamp.

- 10 Insert the supplied in-line check valve into the open end of the 3/8 hose, with the arrow on the check valve pointing AWAY from the valley cover fitting.

! **Warning:** The check valve must be installed in the correct direction. Failure to do so may result in engine damage. Installation can be checked by sucking on the open end of the check valve. You should be able suck air from the valley cover, and you should NOT be able to blow air into the valley cover.



Check Valve Installed

Intake Manifold

11 Insert the remaining piece of 2" long 3/8 hose onto the open end of the check valve. Connect the hose to one of the 3/8 barbs on the vacuum manifold. Secure both ends with a #04 hose clamp.

12 Insert the supplied pushlock hose into the pushlock fitting on the vacuum manifold. Route the line to the front of the vehicle.



Vacuum Manifold Installed

13 Insert the 6-3/4" long 3/8 rubber hose section onto the open 3/8 barb on the vacuum manifold. Secure with a #04 hose clamp.

14 Set the intake manifold on top of the engine. Lift the manifold up and connect the open end of the 3/8 hose to the fitting on the bottom of the manifold. Secure with a #04 hose clamp.



Vacuum Manifold Connected to Intake

15 Connect the rear MAP sensor to the factory harness.



MAP Sensor Connector

- 16** Bolt the intake manifold to the cylinder heads using the supplied M6x25mm flange head bolts and a 10mm socket. The inner set of holes will not be used.

! **Attention:** Start ALL manifold bolts before torquing. The manifold should be torqued in 2 passes according to the sequence shown. On the first pass, torque to 20 inch pounds. On the second pass, torque to 50 inch pounds.

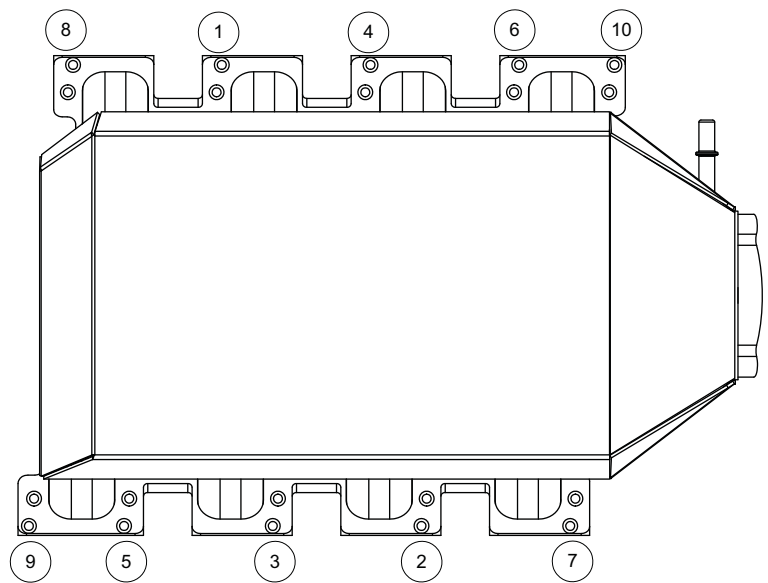

Intake Manifold Torque Sequence



Intake Manifold Install

- 17** Route the factory EVAP line and valve cover PCV line under the intake and to the driver's side. Connect the EVAP electrical connector and vacuum line to the solenoid. Connect the driver's valve cover PCV line. Make sure this hose does not kink. Connect the driver's side vacuum line to the port behind the throttle body. Connect the front MAP sensor.



MAP, EVAP and PCV Lines Connected

Intake Manifold

- 18 Use a 10mm to install the throttle body onto the intake manifold using the factory bolts. Plug in the electrical connector.
- 19 Set the (3) rubber washers provided over the threaded holes on the top of the intake manifold.



Intake Manifold Installed

- 20 Align the holes of the intake cover with the rubber washers. Set the intake cover on the manifold and secure using the supplied 1/4" button head screws and washers.

INTERCOOLER PREP

- 1 Use a 10mm to remove the (2) nuts holding the driver's side transmission cooler bracket to the cooler.
- 2 Install the supplied modified transmission cooler bracket. Let the cooler hang down.
- 3 Locate the brake assist pump. Disconnect the (2) vacuum lines and (1) electrical connector from the pump.
- 4 Use a 13mm to remove the (2) pump bracket bolts holding it to the frame rail. Remove the pump and bracket.
- 5 Use a 10mm to remove the bracket from the pump.
- 6 Use a 13mm and a 10mm to mount the new brake pump bracket to the driver's side frame rail using the factory hardware.
- 7 Mount the pump to the new bracket using the factory bolts. Plug in the vacuum lines and electrical connector.

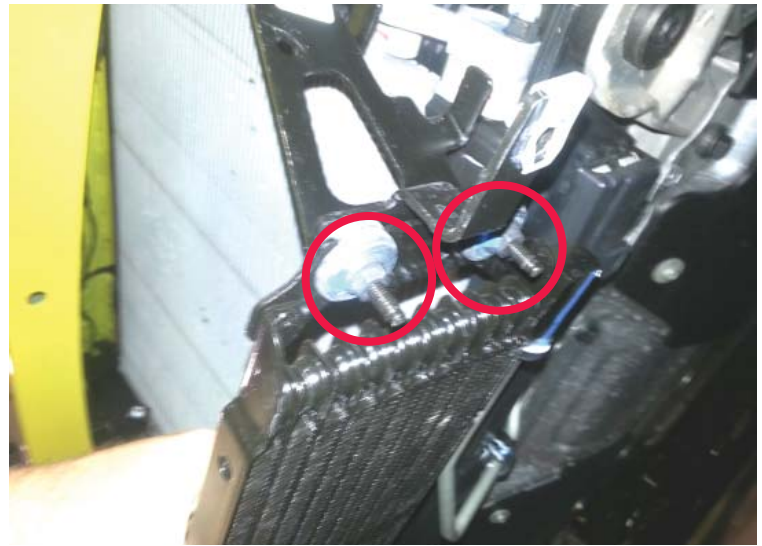

Plastic Radiator Cover (Passenger's)



Brake Assist Pump



Brake Pump Relocated

Intercooler Prep

- 8 Remove the wiring clips from the factory brace between the frame rail and the driver's fender. Use a 10mm to remove the bolt securing the horn to the brace, then use a 10mm to remove the (4) screws holding the brace.



Remove Factory Fender Brace

- 9 Use a saw to cut the brace that is still attached to the frame rail as shown in the picture.

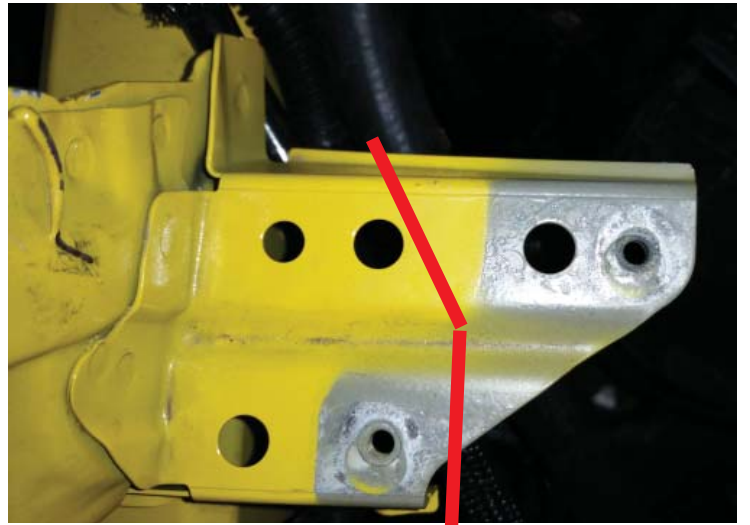

Cut Fender Brace Mount

COMPONENT RELOCATION

- 1 Install (4) of the supplied panel clip nuts on the new fender brace. Squeezing the nuts with pliers or a vice prior to installing them will help them stay on the brace. (2) of the nuts go on the end of the brace to attach to the fender. One goes in the middle of the brace and will be used as a mounting point for the headlight in a later step. The last clip goes on towards the fender to mount the horn.
- 2 Use the factory screws to bolt the fender to the brace.
- 3 Use one of the factory screws to attach the brace to the bracket at the frame rail.
- 4 Use the supplied 6mm screw, nut, and nut for the remaining hole on the frame rail bracket.
- 5 Use a 13mm to remove the top inner bolt on the passenger's side bracket to frame rail. Mount the horn as shown
- 7 Mount the horn as shown using the factory bolt.



Install New Fender Brace



Fender Brace Mounting at Frame Rail

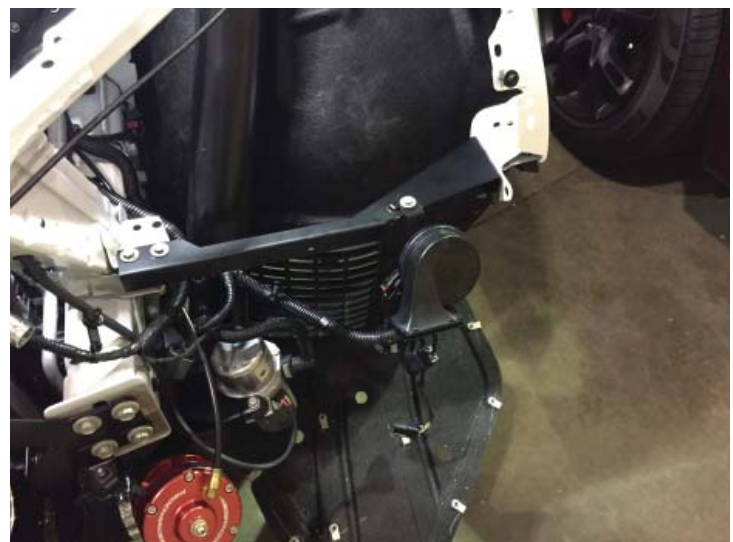

Horn Mounted

Air to Water Intercooler

For air to air intercooler proceed to page: 43

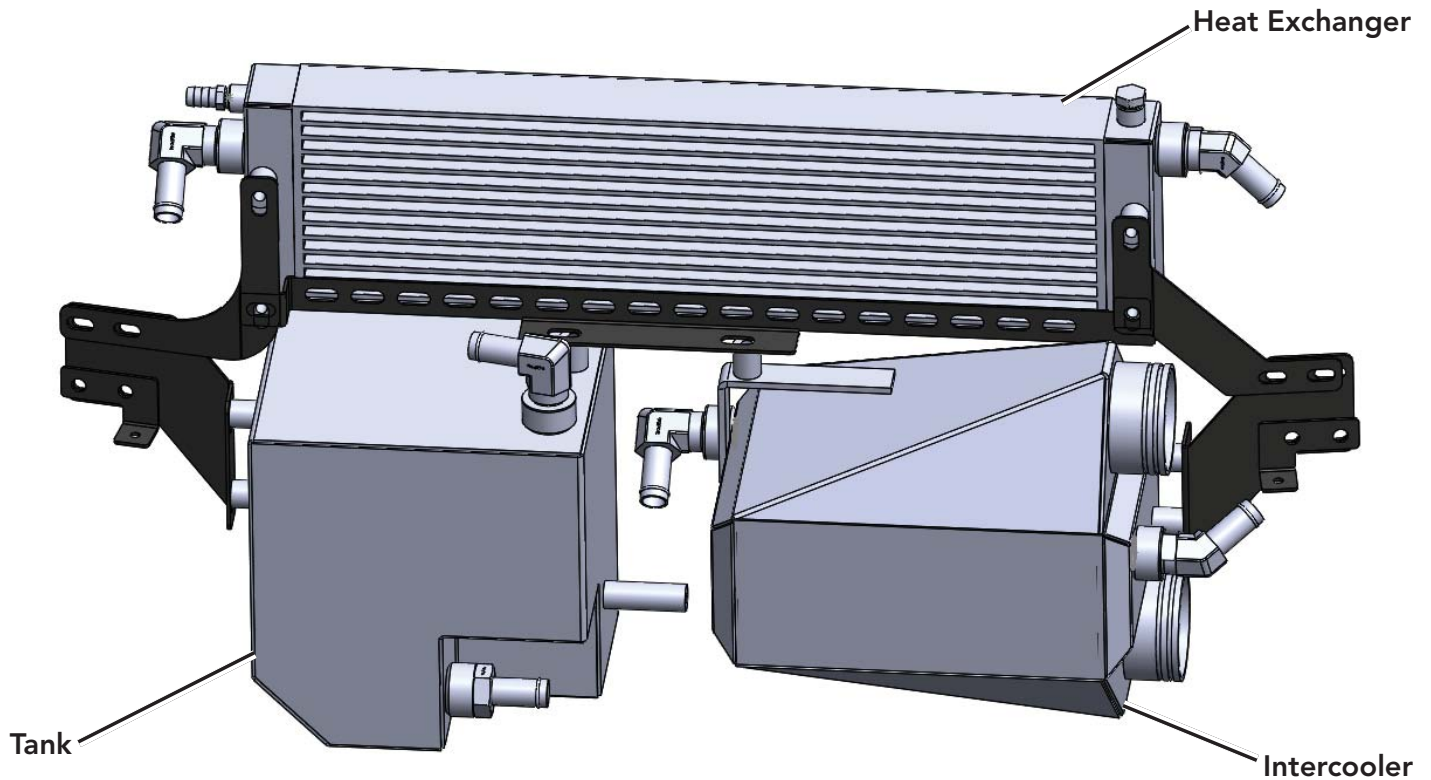

Heat Exchanger, Tank, & Intercooler Mounting

- 1 Use the factory bumper support bolts to mount the heat exchanger, intercooler/tank, and transmission cooler brackets to the frame rails on each side. Leave the bolts loose to allow for adjustment.
- 2 Assemble the heat exchanger with a 90° and a 45° 3/4" hose barb fitting, a straight 1/2" barb to NPT fitting, and an 1/4" NPT plug. See schematic for proper fitting locations. Use thread sealer on the NPT fittings.



Brackets Mounted (Right Side)

- 3 Slide the heat exchanger behind the mounting brackets. Start the upper mounting points with the supplied 3/8" bolts and washers.



Heat Exchanger Mounted

- 4 Attach the lower brace to the lower mounting points on the heat exchanger with supplied 3/8" bolts and washers.

- 5 Assemble the tank with a straight 3/4" barb fitting in the lower port, and a 90° 3/4" barb fitting in the upper port.

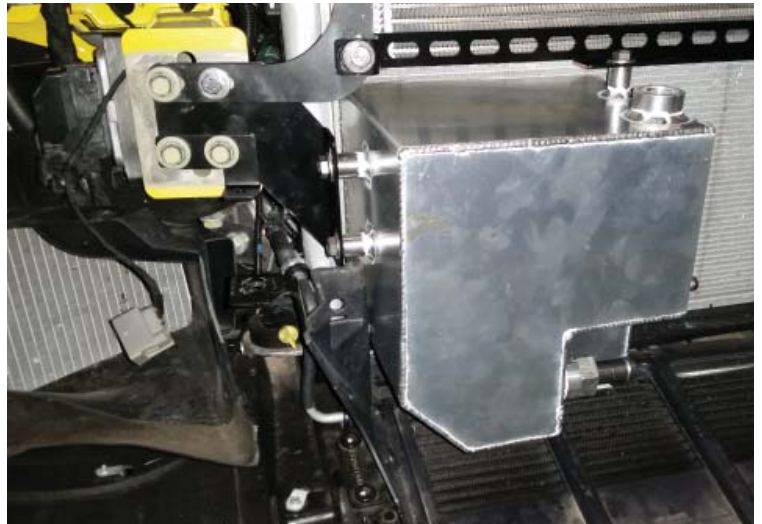

Tank Mounted

- 6 Use (3) supplied 3/8" bolts and washers to mount the tank to the heat exchanger bracket and the frame bracket.

- 7 Assemble the intercooler with a 45° and a 90° 3/4" barb fitting.

- 8 Use (3) supplied 3/8" bolts and washers to mount the intercooler to the heat exchanger bracket and the frame bracket.



Intercooler Assembled

Air to Water Intercooler

- 9 Slide the 3-1/4" long section of 3/4" rubber hose over the straight fitting on the bottom of the tank. Slide the 5" long section of 3/4" hose over the 90° fitting on the intercooler.
- 10 Mount the supplied intercooler bracket to the factory intercooler pump bracket using the supplied M6 serrated bolt and nut.
- 11 Spray the pump inlet and outlet with WD40. Slide the pump into both hoses.
- 12 Use the supplied 5/16" bolt and washer to mount the pump bracket to the threaded stud on the tank. Secure hoses with supplied #12 hose clamps.
- 13 Use a 13mm to remove the (2) lower intercooler bracket to frame bolts on both sides.
- 14 Install the transmission cooler mount brackets on the frame rail using the lower two bolts. Install a clip nut on the protruding tab, with the nut side upward.

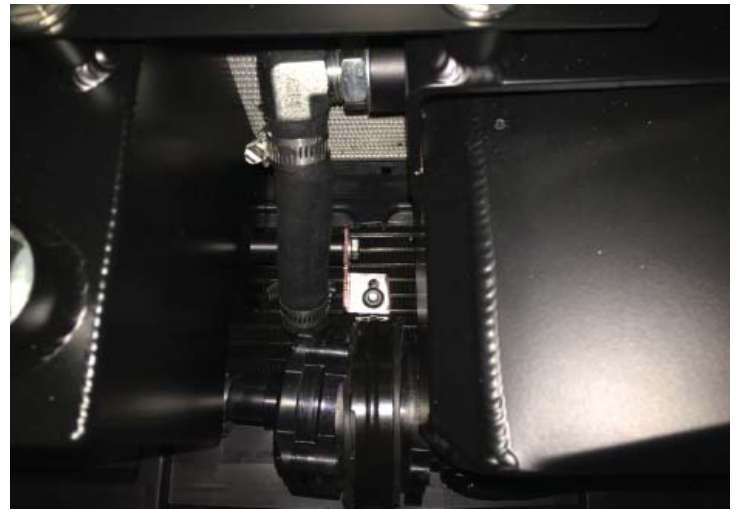

Intercooler Pump Bracket Mounted

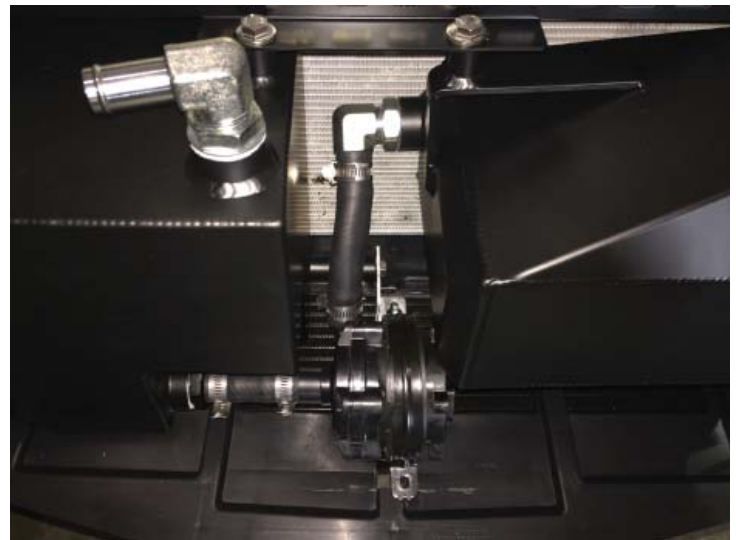

Intercooler Pump Mounted



Left Transmission Cooler Mount Bracket

- 15 Trim the middle rib out of the supplied air shroud as shown to the right.
- 16 Install the supplied modified air shroud to the transmission cooler brackets. Use a 10mm to mount the trans cooler and air shroud to the panel nut on the new transmission cooler mounts with the factory hardware. Reconnect the ambient air temperature sensor to it's factory location.



Trimmed Air Shroud

✓ **Tech Tip:** Trim the supplied air shroud as needed for clearance.

- 17 Adjust the intercooler, heat exchanger and tank, and make sure the inlet to the intercooler on the bottom clears the A/C line. Tighten all of the mounting hardware.



Modified Air Shroud Installed

- 18 Extend the intercooler pump wiring harness using the supplied solder connectors and wire. Use a heat source on the solder connectors to melt the solder being sure the connections are secure. Use the supplied wire loom to cover the wires when complete.

- 19 Plug in the pump harness being sure to zip-tie the harness to keep the wires away from any moving objects or any heat sources.



Intercooler Pump Wiring

AIR TO WATER TUBE ROUTING

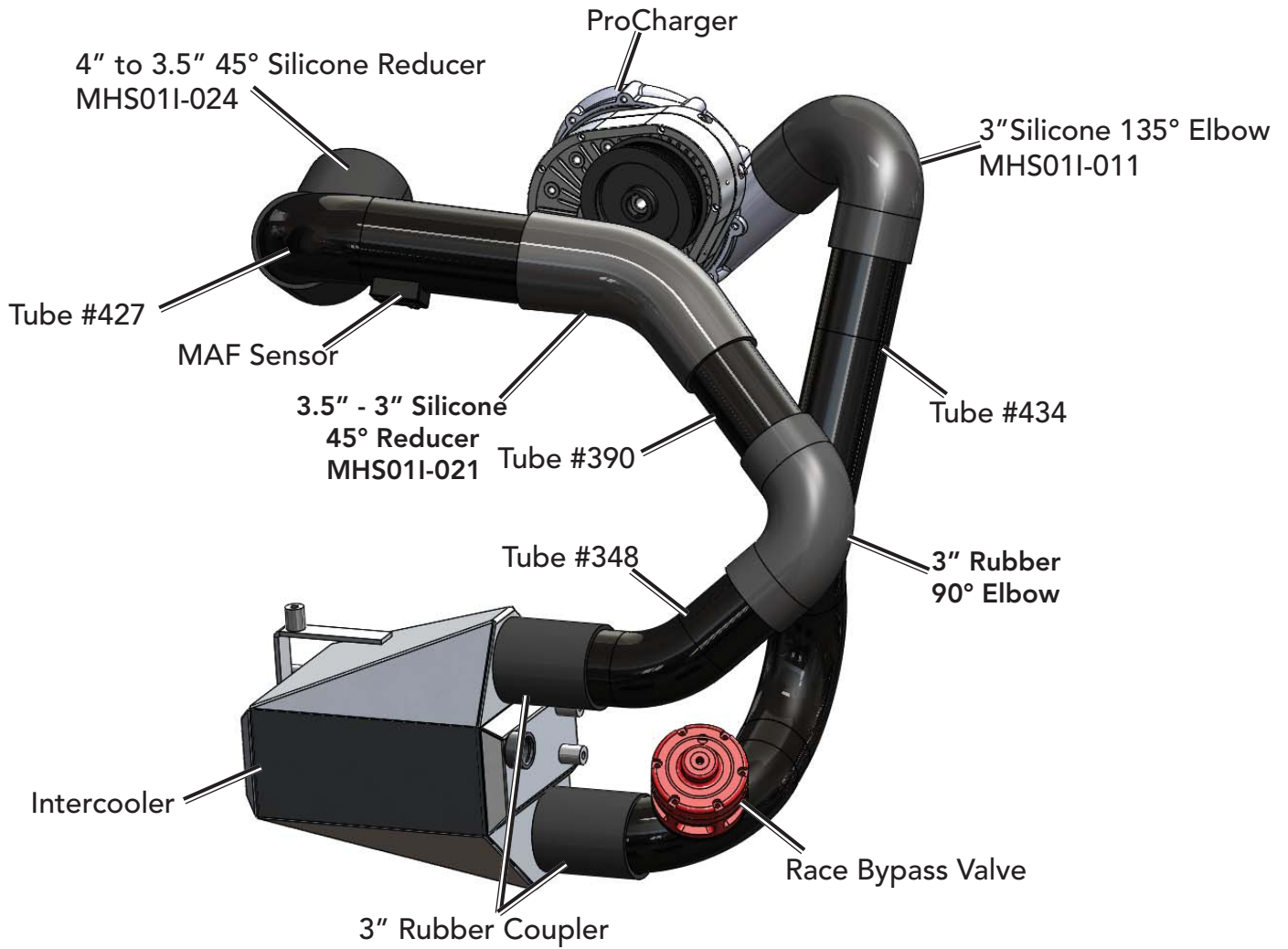

✓ **Tech Tip:** Leave all hose clamps loose to allow for adjustment. Tighten after all tubes are in place.

1 Locate the 135° silicone elbow with uneven legs. Insert the shorter leg of the elbow over the outlet of the supercharger. Secure with the supplied 3.38" T-bolt clamp.



Blower Discharge Tube Installed

2 Slide the 3" long, 3" diameter rubber coupler over the bottom inlet on the intercooler.

3 Install the 90° pushlock fitting into the threaded hole on the top of the race valve. Insert the o-ring into the groove on the flange on tube #434. Clock the race valve with the pushlock fitting toward the top and mount the race valve to the flange using the supplied (6) #10-24 socket head screws. Connect the already installed pushlock line being sure to keep it away from moving parts or heat sources.



Blower Outlet Tube Installed

4 Slide the straight end of tube #434 into the open end of the silicone elbow. Secure with a 3.25" T-bolt clamp. Slide the 90° end of the tube into the coupler at the intercooler. Secure with a #52 hose clamp.

Air to Water Intercooler

- 5 Attach the 4" long straight rubber coupler to the top intercooler outlet.
- 6 Insert the shorter leg of tube #348 into the rubber coupler.
- 7 Slide the 3" rubber 90° elbow over the longer end of tube #348.



Intercooler Tube Routing

- 8 Insert tube #390 into the open end of the rubber 90° elbow.
- 9 Use a T15 torx to remove the (2) screws holding the MAF sensor to the factory air box.
- 10 Use a 7mm to install the MAF sensor into the bung on tube #427 using the supplied M4 screws and washers.



Remove MAF Sensor from Factory Air Box

- 11 Slide the 3.5" to 3" silicone 45° elbow over the open end of tube #390.

✓ **Tech Tip:** Cutting the airbox tab may be necessary for proper tube clearance.

- 12 Slide the 4" to 3.5" 45° silicone reducer onto the shorter leg of the tube #427.

- 13 Attach tube #427 to the throttle body and into the open end of the silicone 45° elbow. Use a 4.25" T-bolt clamp and the throttle body, and 3.75" T-bolt clamps at the 3.5" tube connections.

- 14 Adjust the tubing so it is tight against the fan shroud and won't touch the tensioner.

- 15 Connect the MAF sensor to the factory connector using the supplied MAF extension harness.

- 16 Route the harness away from any moving parts. Use zip ties to secure.



MAF Tube Routing

INTERCOOLER COOLANT ROUTING

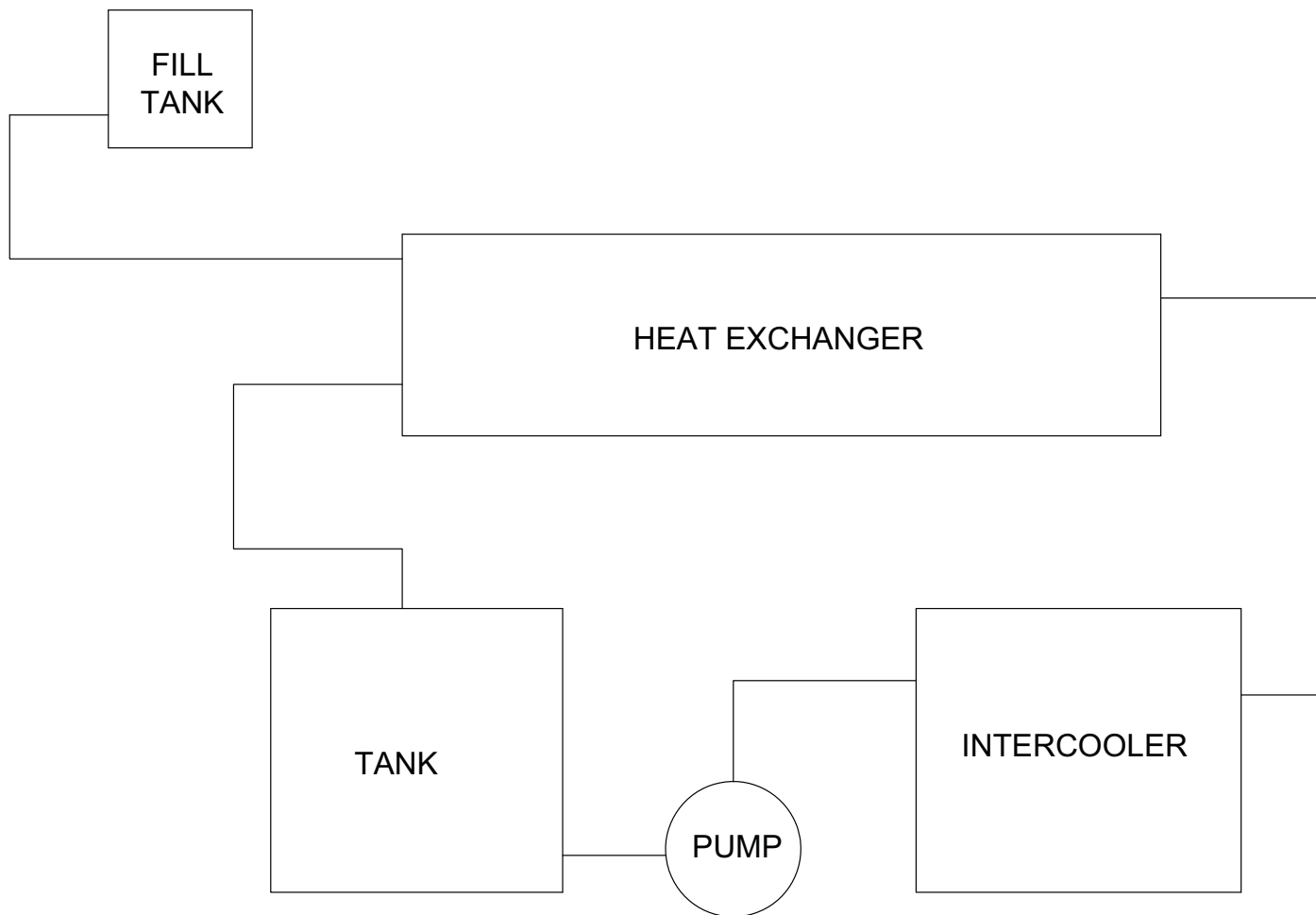

- 1** Apply sealer on the threads of the 1/2" brass 90° barb fitting and install it into the fill tank. Point the fitting parallel to the bottom, facing towards the mounting flange.
- 2** Use a 10mm to remove the outermost bolt on the passenger's side of the metal radiator cover panel. Slide the mounting flange on the fill tank under the panel and align the larger mounting hole with the bolt hole that was removed. Reinstall the bolt. The smaller mounting hole must line up with the headlight mounting hole.



Fill Tank Installed

- 3 Install the 1/2" rubber hose from the fill tank to the straight fitting on the top of the heat exchanger. Secure with #6 hose clamps.



Fill Tank Hose Connected

- 4 Install one of the 16" sections of 3/4" rubber hose from the 45° fitting on the intercooler to the 45° fitting on the heat exchanger. Secure with #12 hose clamps.



Intercooler to Heat Exchanger Hose

- 5 Remove the 90° fitting on top of the tank. Place a funnel in the tank and fill with coolant. When full, reinstall the fitting.

- 6 Install the other 16" section of 3/4" hose from the 90° fitting on the heat exchanger to the 90° fitting on top of the tank. Trim the hose to the proper length if necessary. Secure with #12 hose clamps.

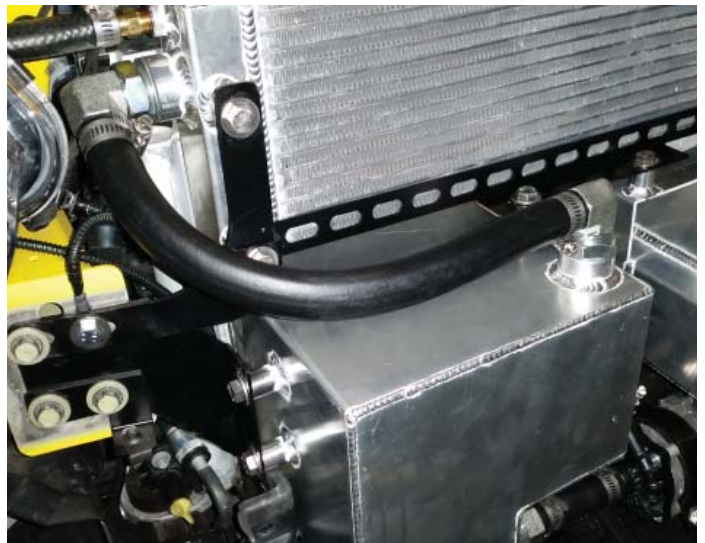

Heat Exchanger to Tank Hose

Intercooler Coolant Routing

- 7 Remove the hex plug from the top driver's side of the heat exchanger.
- 8 Slowly add coolant to the fill tank until the coolant reaches the hex plug on the top of the heat exchanger. Reinstall the hex plug. Top off the fill tank. This process will ensure there is the least amount of air in the system as possible.

Continue to page 49.



Coolant Plumbing Complete

Air to Air Intercooler

Race intercooler only, stage 2 intercooler proceed to step 3.

- 1 Install the intercooler brackets to the frame rail where the bumper was mounted. The bracket with the hole goes to the passenger side. Leave the bolts loose for adjustment.

- 2 Place the intercooler between the brackets. Start the (4) supplied 3/8" bolts and washers through the brackets and into the bungs on the intercooler. Leave loose.

Proceed to step 7.

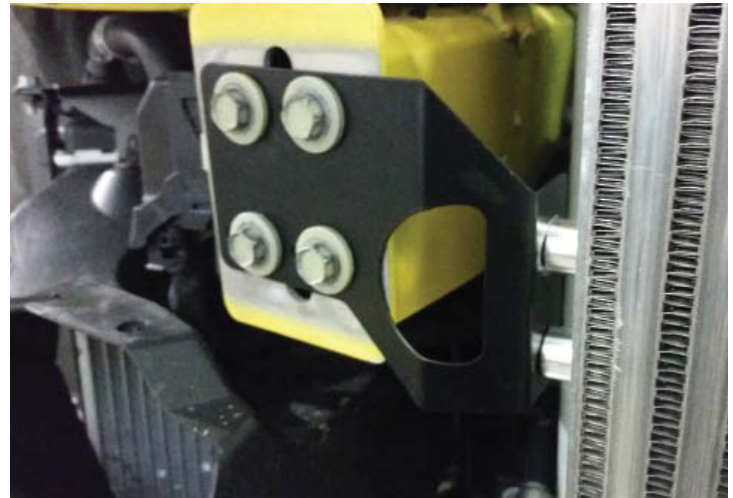

Intercooler Brackets Mounted (Right Side)



Race Intercooler Mounted

Stage 2 intercooler only.

- 3 Place the intercooler brackets between the frame rails and the bumper, orient as shown

- 4 Reinstall the bumper, but leave the bolts loose to allow the intercooler brackets to slide for adjustment.



Intercooler Bracket Orientation

Air to Air Intercooler

- 5 Slide the intercooler up between the bumper and the radiator.
- 6 Start the (4) supplied 3/8" bolts and washers through the brackets and into the bungs on the intercooler. Leave loose.
- 7 Adjust the intercooler and make sure the inlet to the intercooler on the bottom clears the A/C line.
- 8 Use a 9/16" to tighten the intercooler bolts. Use a 13mm to tighten the frame bolts.



Stage 2 Intercooler Installed

AIR TO AIR TUBE ROUTING

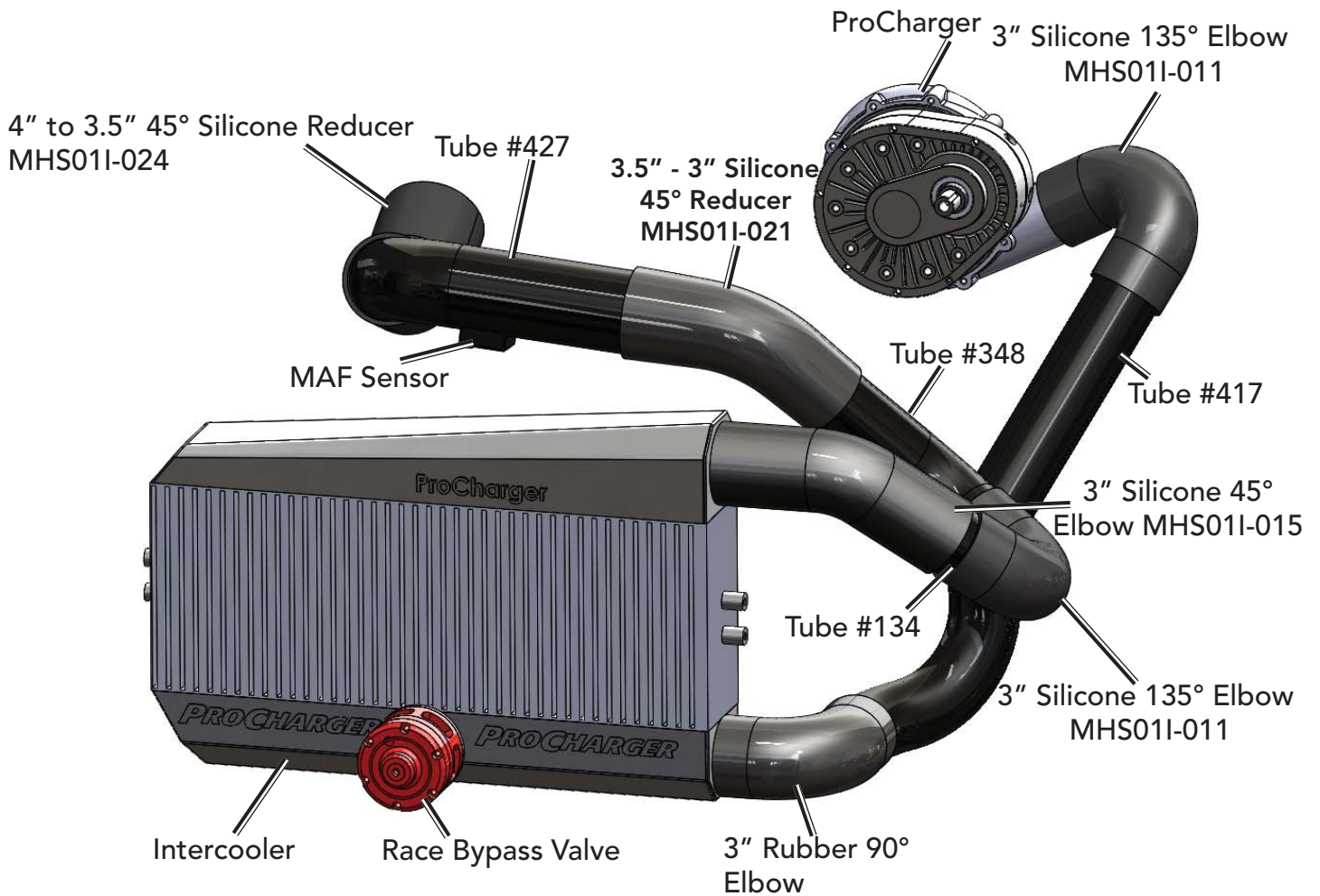

Air to Air Intercooler



Tech Tip: Leave all hose clamps loose to allow for adjustment. Tighten after all tubes are in place.

- 9 Locate the 135° silicone elbow with uneven legs. Insert the shorter leg of the elbow over the outlet of the supercharger. Secure with the supplied 3.38" T-bolt clamp.
- 10 Slide tube #417 into the open end of the silicone elbow.



Blower Discharge Tube Installed

- 11 Slide the longer leg of one of the 90° rubber elbows over the open end of tube #417.
- 12 Slide the short end of the elbow over the lower intercooler outlet.



Lower Intercooler Connection

- 13 Attach one end of the 45° silicone elbow to the top intercooler outlet.
- 14 Insert the short coupling tube #134 in the other end of the 45° elbow.
- 15 Slide the other 135° silicone elbow over the other end of the coupling tube #134.
- 16 Insert the shorter leg of tube #348 into the 135° elbow.



Intercooler Tube Routing

- 17 Use a T15 torx to remove the (2) screws holding the MAF sensor to the factory air box.
- 18 Use a 7mm to install the MAF sensor into the bung on tube #427 using the supplied M4 screws and washers.

✓ **Tech Tip:** Cutting the airbox tab may be necessary for proper tube clearance.

- 19 Slide the 3.5" to 3" silicone 45° elbow over the longer leg of tube #348.
- 20 Slide the 4" to 3.5" 45° silicone reducer onto the shorter leg of the tube #427.
- 21 Attach tube #427 to the throttle body and into the open end of the silicone 45° elbow. Use a 4.25" T-bolt clamp and the throttle body, and 3.75" T-bolt clamps at the 3.5" tube connections.
- 22 Adjust the tubing so it is tight against the fan shroud and won't touch the tensioner.
- 23 Connect the MAF sensor to the factory connector using the supplied MAF extension harness.
- 24 Route the harness away from any moving parts. Use zip ties to secure



Remove MAF Sensor from Factory Air Box



MAF Tube Routing

Air to Air Intercooler

25 If equipped with the race valve option, insert the o-ring into the groove on the intercooler flange and mount the race valve to the flange using the supplied (6) #10-24 socket head screws. Install the 90° pushlock fitting into the threaded hole on the top of the valve. Connect the already installed pushlock line being sure to keep it away from moving parts or heat sources.



Race Valve Installed

26 Install the supplied modified air shroud to the transmission cooler brackets. Use a 10mm to mount the trans cooler and air shroud to the panel nut on the new transmission cooler mounts with the factory hardware. Reconnect the ambient air temperature sensor to its factory location.



Modified Air Shroud Installed

27 Reinstall the passenger's brake cooling duct. Use the factory plastic push clips through the air shroud into the cooler brackets.

28 Install the supplied 1-1/2" rubber hose onto the bung on the intercooler. Secure with a #24 hose clamp.

29 Cut the hose to the appropriate length. Install the 90° pushlock fitting into the threaded hole on top of the valve. Insert the Bullet surge valve into the hose. Secure with a #24 hose clamp.



Surge Valve Installed

30 Connect the already installed pushlock line into the 90° fitting being sure to keep it away from moving parts or any heat sources.



Tech Tip: Proflow Surge valve shown. The bullet valve will be similar but without the filter or mechanical linkage.

FINAL ASSEMBLY

- 1 Use a 1/2" drill bit to drill a hole in the end of the air filter. Insert the 1/2" end of the supplied plastic hose barb into the air filter hole.
- 2 Slide the air filter over the rotomold inlet tube.
- 3 Slide the tube over the inlet of the supercharger. Adjust the tube and the air filter and secure with the supplied hose clamps.

✓ **Tech Tip:** The F1A-94 supercharger option will use a rubber elbow and steel tube in place of the rotomold inlet tube.

- 4 Insert the short leg of the supplied 5/8" rubber hose over the open port on the PCV reservoir. Cut the hose to fit properly over the port. Secure with a #10 hose clamp.



Plastic Fitting Installed in Air Filter



Air Inlet Installed



PCV Reservoir Hose



F1A-94 Air Inlet Installed

Final Assembly

- 5 Route the hose around the back of the engine and connect it to the plastic fitting on the air filter. Secure the line with zip ties.

- 6 Reinstall the headlights.

✓ **Tech Tip:** It is highly recommended that colder heat range spark plugs are installed. NGK 6510 spark plugs are recommended for most applications.

- 7 Remove the hood air diverter by removing the (3) bolts with a 10mm.

- 8 On the back side of the fascia, remove the plastic bumper center section by prying off the (2) metal clips.

- 9 Reinstall the front fascia.

For Proflow equipped vehicles only.

- 10 From under the car, use zip ties to retain the surge valve so it does not damage the radiator.

✓ **Tech Tip:** Before shutting the hood be sure there is adequate clearance between the hood and the supercharger pulley/ supercharger. Additional clearance may be gained by adjusting up the hood bumpers.

- 10 Start the engine. Check for leaks. After reaching operating temperature, shut the engine off and allow to cool down. Fill coolant as needed.



PCV Hose Routed



Hood Air Diverter



Fascia Clips



CONGRATULATIONS! YOU HAVE COMPLETED THE INSTALLATION OF YOUR NEW PROCHARGER SUPERCHARGER SYSTEM. READ THE FOLLOWING PAGES CAREFULLY FOR OPERATION AND MAINTENANCE INSTRUCTIONS, AS WELL AS WARRANTY INFORMATION.

OPERATION AND MAINTENANCE

Cold Starting

Never race your engine and ProCharger supercharger when your engine is cold. Allow the water temperature to climb into operating range for several minutes before driving above 2,500 rpm, to ensure adequate oil lubrication.

Fuel Quality

With a properly installed intercooled ProCharger supercharger system, detonation should not occur. For the best performance and reliability, use premium grade fuel (91 octane or higher). Listen for signs of detonation after refueling, and after replacement or modification of any fuel system component(s). If detonation occurs, reduce the throttle and locate the source.

Ignition System Maintenance

If your spark plugs are more than a year old or have more than 10,000 miles logged, you should consider changing them before driving your vehicle under load. Spark plug wires should be changed if visibly damaged or when resistance exceeds factory specifications.

Air Filter Maintenance

Your air filters should be cleaned periodically, potentially as often as every 10,000 miles or 6 months, even though a service interval of 50,000 - 100,000 miles is quoted by the manufacturer under normal driving conditions. A clogged air filter will result in decreased boost levels and vehicle performance. Be sure to re-oil the cleaned filter before re-installing. Always operate your vehicle with an air filter; failure to do so may result in damage to your ProCharger supercharger and personal injury!

Belt Replacement

The serpentine belt, which turns your ProCharger supercharger, will stretch after initial run-in, and should be retightened after the first hundred miles. Tighten the belt sufficiently to avoid slippage, but do not overtighten. Overtightening the belt could cause damage to the ProCharger supercharger's precision bearings. When re-installing the belt, use the belt routing diagram in this manual. If you reuse a thrown belt and find that it needs frequent re-tightening, the belt is damaged and should be replaced. Gates Micro-V belts can be bought from ATI or from your local parts store.

ProCharger Oil Change Intervals

The first oil change should be performed at 500 miles and at 6,000 mile intervals thereafter. Clean the drain plug after every oil change. Drain oil by removing the drain plug. Clean off the drain plug before re-installing.

ProCharger Oil Level

The ProCharger supercharger's oil level must be checked periodically to ensure the proper lubrication. The dipstick can be loosened using a flat blade screwdriver or a coin. When installed, the oil level should remain between the minimum (MIN) and maximum (MAX) indicators at all times.

! **Warning:** *Filling the ProCharger higher than the maximum level on the dipstick can lead to bearing and seal damage. The supercharger is a sealed unit and should not normally require the addition of oil between service intervals. If excessive usage is noted, the unit should be sent to ATI for inspection and repair. The dipstick fitting should be firmly tightened after changing or checking the oil level.*

General

When removing the dipstick, be sure to retain the nylon washer. A spare nylon washer and o-ring is included. Use only the ATI supplied nylon washer and o-ring when servicing the oil dipstick and drain plug. A discoloration of the oil and residue on the drain plug may occur during the initial oil changes. This is normal and will gradually decrease. For the proper positioning of the ProCharger supercharger, the serial tag should be pointing upwards. Installing the ProCharger supercharger in another position will cause inadequate oiling and supercharger failure. If you have any questions about the maintenance of your supercharger, contact ATI.

! **Warning:** *The supercharger contains no oil from the factory. The unit must be filled prior to use. Use only ATI supplied oil in your ProCharger. The ATI oil has been specially formulated for the bearings in the ProCharger and use of oil other than that supplied by ATI will void your warranty.*

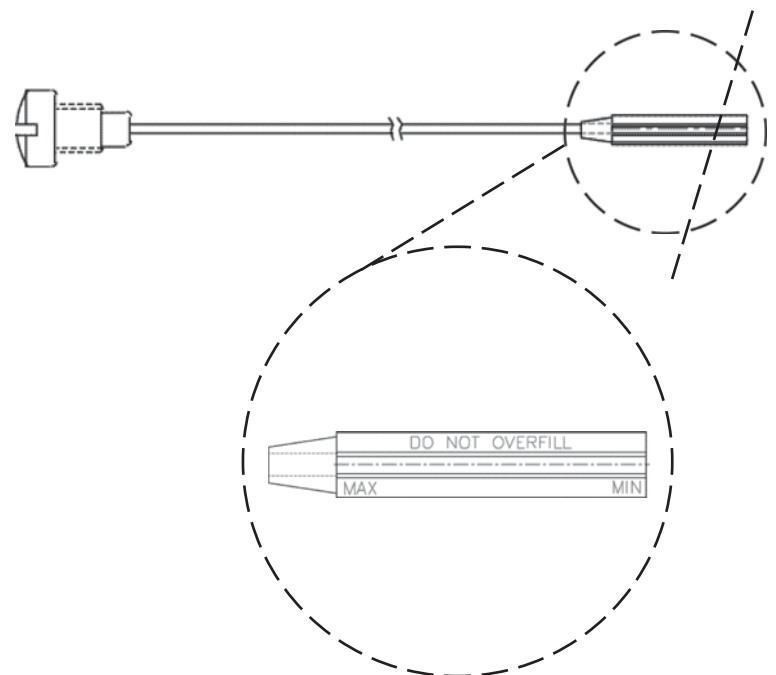
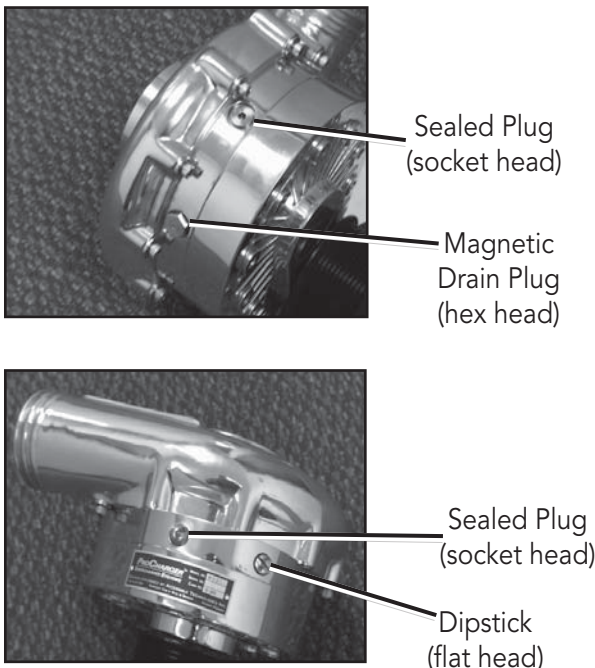

LIMITED WARRANTY

Accessible Technologies, Inc. (ATI) provides a limited twelve (12) month warranty on the ProCharger supercharger against defects in materials and workmanship unless otherwise specified. This limited warranty starts on the date of original purchase from your local dealer, or date of shipment from the factory. This limited warranty coverage is extended only to the original owner and excludes hoses, sleeves, and electronic components manufactured by other companies. IF THE SUPERCHARGER'S DRIVE RATIO IS ALTERED IN ANY WAY FROM THE FACTORY SETTING, WARRANTY COVERAGE IS VOID. USE OF ANY PULLEY NOT MANUFACTURED OR SUPPLIED BY ATI VOIDS ALL WARRANTY COVERAGE. ATI's warranty obligations are limited to the terms below:

ATI agrees to honor a warranty claim at its sole discretion and only after inspection at the ATI factory. No warranty will be honored if any part of the product is found to have been improperly installed, tampered with, mishandled, or misused in any way. Disassembly of the ProCharger supercharger or removal of the ProCharger supercharger's serial plate voids all warranties. Claims for freight damages should be directed to the freight company.

If ATI's limited warranty applies, your product will be repaired or replaced at ATI's discretion and shipped back. If the limited warranty does not apply, ATI will advise you of the specific reason, cost of the repair, and delivery time. After advising you of this information we will, at your option, either proceed with repairs or return your product to you in the state in which it was received. In either case the product will be shipped to you, insured at replacement value. Therefore, you will pay the return shipping and insurance charges if ATI's limited warranty does not apply to your product.

THE WARRANTY AND REMEDIES SET FORTH ABOVE ARE EXCLUSIVE AND IN LIEU OF ALL OTHERS, ORAL OR WRITTEN, EXPRESS OR IMPLIED. THE DURATION OF ANY AND ALL WARRANTIES ON THE PRODUCTS DISCUSSED ARE LIMITED TO THE PERIOD IDENTIFIED ABOVE. ATI IS NOT RESPONSIBLE IN ANY EVENT FOR DIRECT, SPECIAL, INCIDENTAL OR CONSEQUENTIAL DAMAGES. No ATI dealer, agent, or employee is authorized to make any modification, extension, or addition to this warranty.

To obtain service under this warranty you must do the following during the warranty period:

Phone ATI (913-338-2886) and provide us with the following information:

- ProCharger supercharger serial number.
- Vehicle year, make, model, engine modifications, and other modifications.
- Description of perceived issue.

If a solution to your issue can not be found after the above phone consultation, you will be assigned a return authorization number (RMA). You must then properly package and ship your product, at your expense, to the ATI factory. The product should be carefully packaged in a rugged box.

Include the following information inside the box with your product:

- Copy of your original invoice or receipt.
- Name, address, and daytime telephone number.
- Return authorization number (RMA).
- Vehicle year, make, model, engine modifications, and other modifications.
- Description of perceived issue.

Clearly mark the warranty claim number on the top and one side of the box in characters at least 2" tall. Properly package the product and ship it, prepaid and insured for the retail value of the component(s) being returned, to the following address:

**Accessible Technologies, 14801 West 114th Terrace,
Lenexa, Kansas 66215**

This Page is Intentionally Left Blank



**Accessible Technologies, Inc.
14801 W. 114th Terrace
Lenexa, KS 66215
Phone: 913.338.2886
Fax: 913.338.2879
techserv@procharger.com**

**Accessible Technologies, Inc.
©2017 ATI, All Rights Reserved
Part Number PMGY1A-005 Rev. A**

