

SHAD

HONDA PCX 125i '10- KIT RESPALDO HOPC10RV



1 261893 x1



2 261277 x2
Ø20 Ø11 x 25



3 303020 x2
Ø8



4 304036 x2
M8 x 45 Din 7380

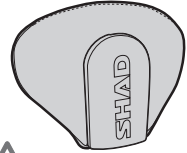

NOT INCLUDED

WARNING!

GB

Do not fully tighten the screws until it is ensured that the KIT is correctly attached and aligned.

E

No apretar los tornillos del todo hasta asegurarse que el KIT está correctamente colocado y alineado.

D

Ziehen Sie die Schrauben nicht ganz fest, bevor Sie sich nicht vergewissert haben, daß der Bausatz korrekt eingestellt und ausgerichtet ist.

I

Non stringere del tutto le viti fin tanto non si è sicuri che il kit è collocato correttamente e allineato.

F

Ne pas serrer les vis avant d'être sûr que le KIT est correctement monté et ajusté.

PCX 125i '14-

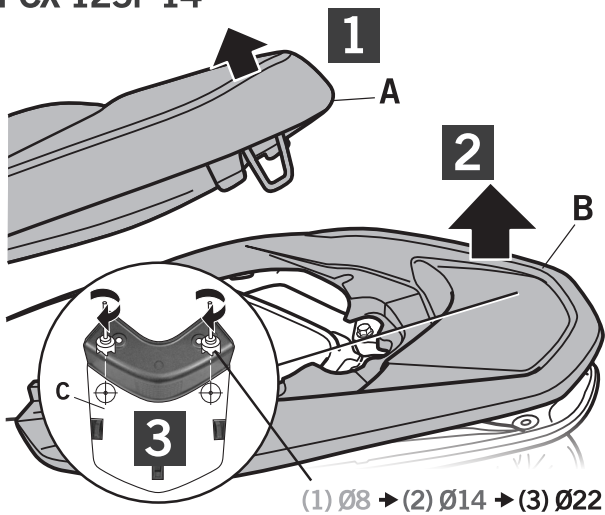

(1) Ø8 → (2) Ø14 → (3) Ø22

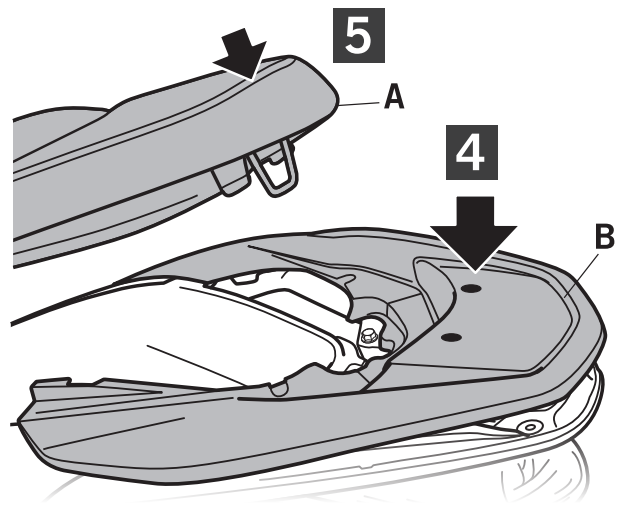

PCX 125i '10-13

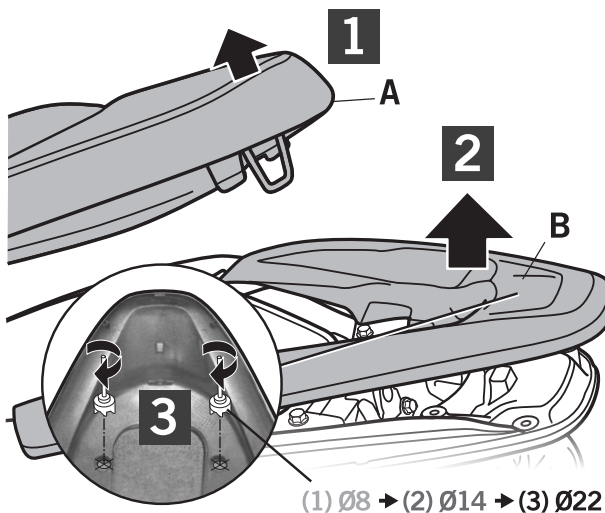

(1) Ø8 → (2) Ø14 → (3) Ø22

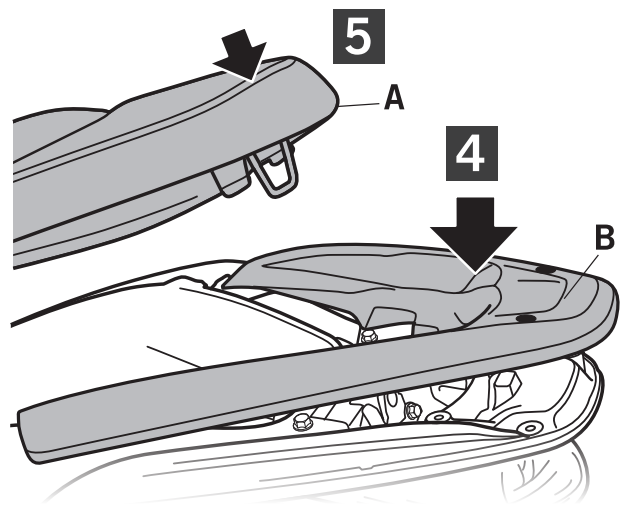

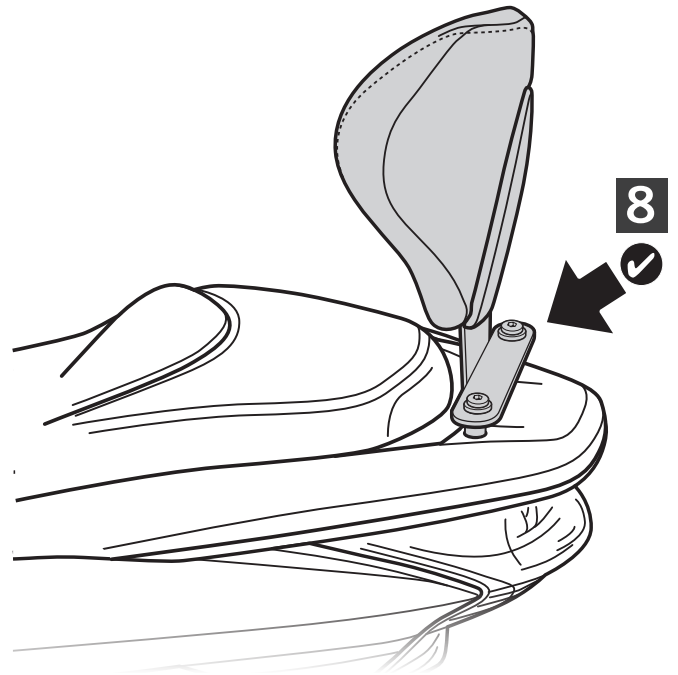
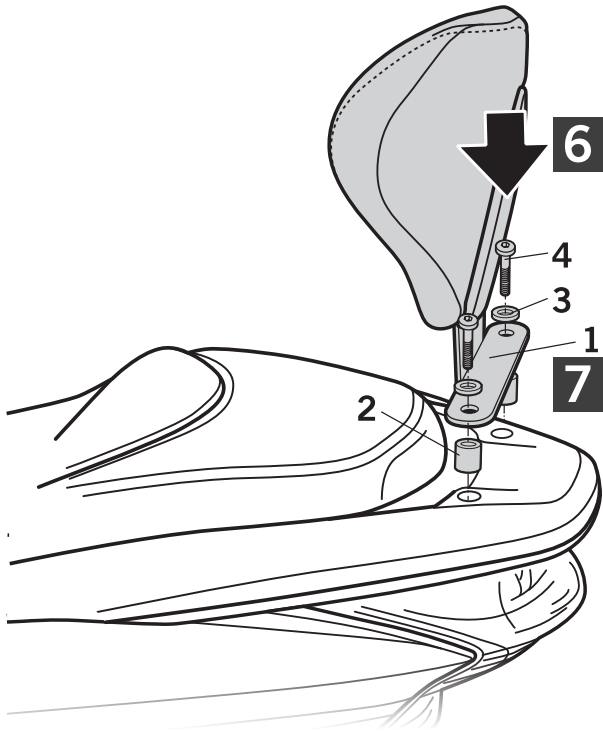

PCX 125i '14-

- Ⓔ Plantilla necesaria solo para modelos desde 2014.
- ⒼⒷ Necessary pattern only for models from 2014.
- Ⓕ Gabarit nécessaire seulement pour des modèles depuis 2014.
- Ⓓ Notwendiges Muster nur für Modelle von 2014.
- Ⓛ Sagoma necessaria soltanto per i modelli a partire da 2014.

