



TEL: 1-866-XANATOS

INSTALLATION INSTRUCTIONS

3" SIDEBARS

2020 JEEP GLADIATOR

PART# 9B080420SS/ 9B080420A

Parts List

1	Driver/Left Side Step	1	Driver/Left Rear Support Bracket
1	Passenger/Right Side Step	1	Passenger/Right Rear Support Bracket
1	Driver/Left Front Mounting Bracket	6	10-1.5mm x 30mm Hex Bolts
1	Passenger/Right Front Mounting Bracket	12	10mm x 24mm x 2.2mm Flat Washers
1	Driver/Left Center Mounting Bracket	6	10mm Nylon Lock Nuts
1	Passenger/Right Center Mounting Bracket	6	8-1.25mm x 35mm Hex Bolts
1	Driver/Left Rear Mounting Bracket	6	8mm x 28mm x 3mm Flat Washers
1	Passenger/Right Rear Mounting Bracket	6	8mm Lock Washers
1	Driver/Left Front Support Bracket	12	8mm Combo Bolts
1	Passenger/Right Front Support Bracket	12	6-1.0mm x 25mm Hex Bolts
1	Driver/Left Center Support Bracket	24	6mm x 22mm x 2mm Flat Washers
1	Passenger/Right Center Support Bracket	12	6mm Nylon Lock Nuts

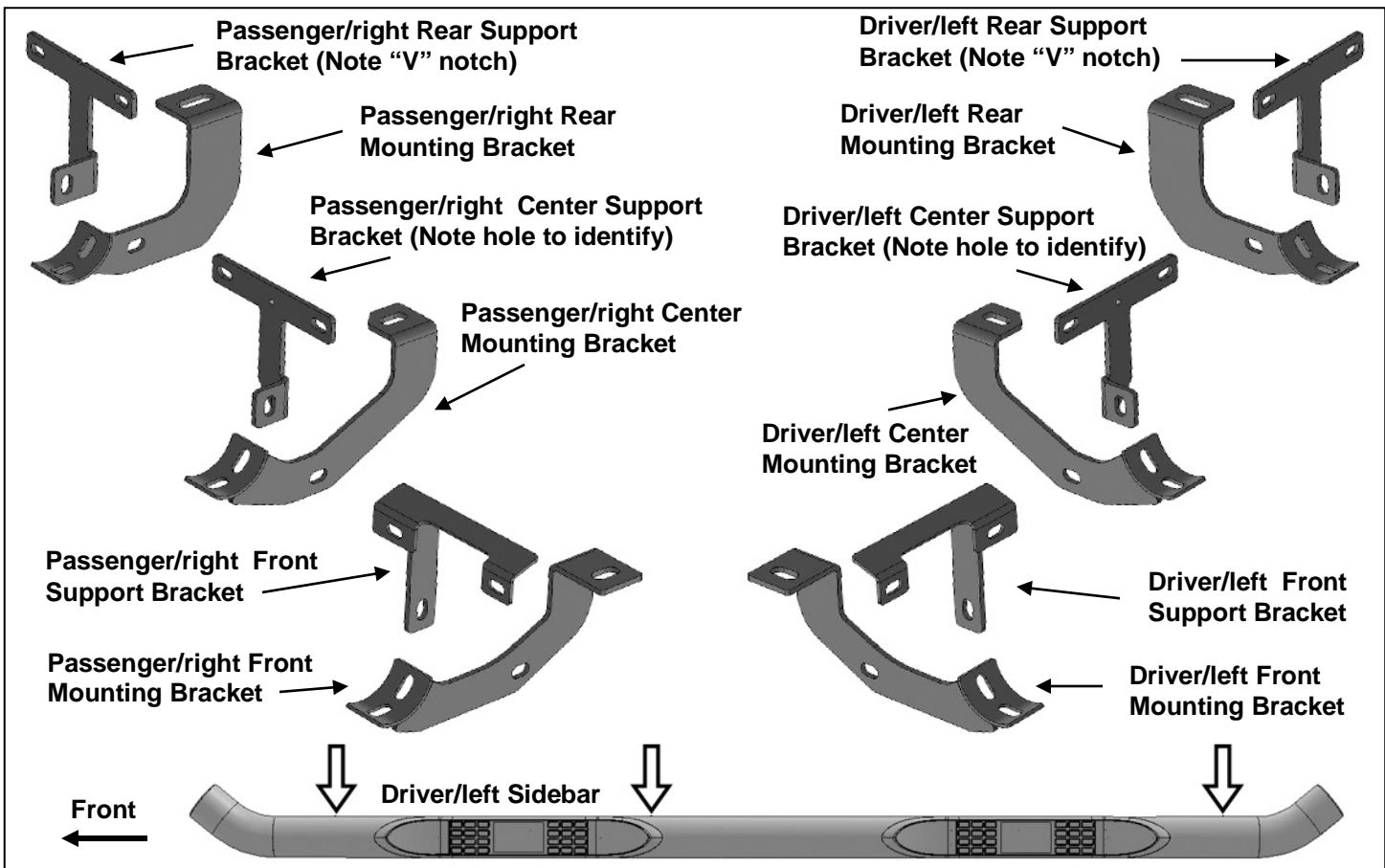

PROCEDURE:

1. REMOVE CONTENTS FROM BOX. VERIFY ALL PARTS ARE PRESENT. READ INSTRUCTIONS CAREFULLY BEFORE STARTING INSTALLATION. FACTORY INSTALLED OR AFTERMARKET "ROCK RAILS," SIDE STEPS OR RUNNING BOARDS MUST BE REMOVED.
2. Start installation toward the front of the driver/left of the vehicle. Locate the (4) pairs of factory mounting holes visible along the pinch weld, **(Figure 1)**. Installation will use the #1, #2 and #4 mounting locations.
3. Select the driver/left front Mounting Bracket, **(Figure 2)**. Attach the top of the Bracket to the threaded hole in the bottom of the floor panel with the included (1) 8mm x 35mm Hex Bolt, (1) 8mm Lock Washer and (1) 8mm Flat Washer, **(Figures 3 & 4)**. Leave hardware loose at this time.
4. Select the driver/left front Support Bracket, **(Figure 2)**. **VERY IMPORTANT:** The 6 Mounting and Support Brackets look very similar. Use the instructions to properly identify each Bracket.

5. Line up the top of the Support Bracket with the (2) factory holes in the pinch weld. Attach the Support Bracket to the back of the pinch weld with the included (2) 6mm x 25mm Hex Bolts, (4) 6mm Flat Washers and (2) 6mm Nylon Lock Nuts, **(Figure 5)**. Line up the lower mounting tab on the Support Bracket with the back of the Mounting Bracket. Attach the Support Bracket to the Mounting Bracket with (1) 10mm x 30mm Hex Bolt, (2) 10mm Flat Washers and (1) 10mm Nylon Lock Nut, **(Figures 5 & 6)**. Do not fully tighten hardware at this time.
6. Move to the #2 mounting location. Select the driver/left Center Mounting Bracket and Support Bracket, **(Figure 7)**. Repeat **Steps 2—5** to install the Center Bracket and Support Bracket, **(Figures 8—10)**. **NOTE:** The top of the center Mounting Bracket features a cut off corner for identification purposes. The top of the center Support Bracket features a small hole in the center for identification purposes.
7. Move to the last mounting location toward the rear of the cab. Select the driver/left rear Mounting Bracket and Support Bracket, **(Figure 11)**. Repeat **Steps 2—5** to install the rear Bracket and Support Bracket, **(Figure 12—14)**. **NOTE:** The top of the rear Support Bracket features a small "V" cut for identification purposes. Use the instructions to correctly identify all Brackets, **(Figure 11)**.
8. Select the driver/left sidebar. Carefully position the Sidebar onto the (3) Mounting Brackets. **IMPORTANT:** Do not slide, (front to back or rotate), the Sidebar on the Brackets or damage to the finish on the Sidebar may result. Attach the Sidebar to the Mounting Brackets with (6) 8mm x 25mm Combination Hex Bolts, **(Figures 15—17)**. Do not tighten hardware. **NOTE:** Mounting cradles on the front and center Brackets should be inline face the rear of the vehicle, cradle on rear Bracket should face forward for proper installation. Snug all hardware but do not tighten at this time.
9. Adjust and level the Sidebar and tighten all hardware.
10. Repeat **Steps 2—9** for passenger/right Sidebar installation.
11. Do periodic inspections to the installation to make sure that all hardware is secure and tight.

To protect your investment, wax this product after installing. Regular waxing is recommended to add a protective layer over the finish. Do not use any type of polish or wax that may contain abrasives that could damage the finish.

For stainless steel: Aluminum polish may be used to polish small scratches and scuffs on the finish. Mild soap may be used to clean the Sidebar.

For gloss black finishes: Mild soap may be used to clean Sidebar.

Driver/left Side Installation Pictured

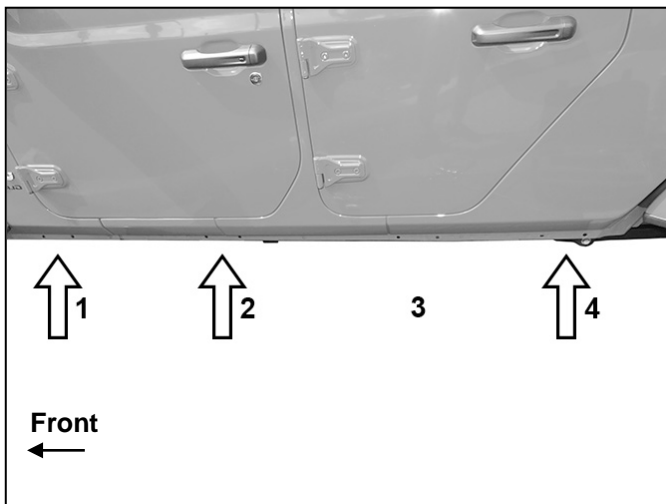

(Fig 1) Driver/left mounting locations

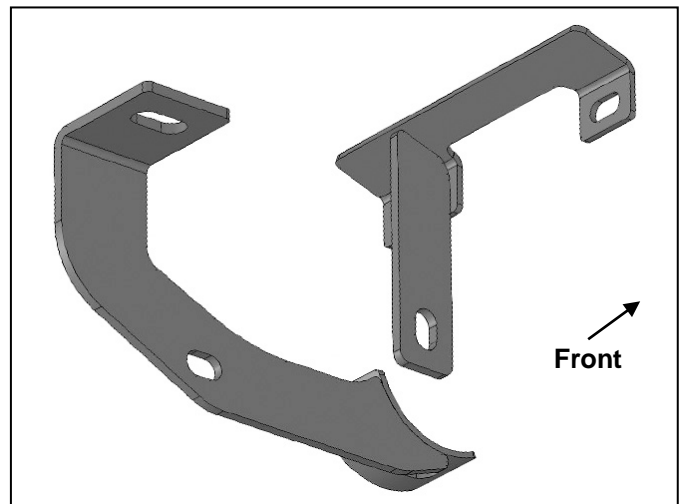

(Fig 2) Driver/left front Mounting and Support Bracket

Driver/left Side Installation Pictured

- 8mm x 35mm Hex Bolt
- 8mm Lock Washer
- 8mm Flat Washer

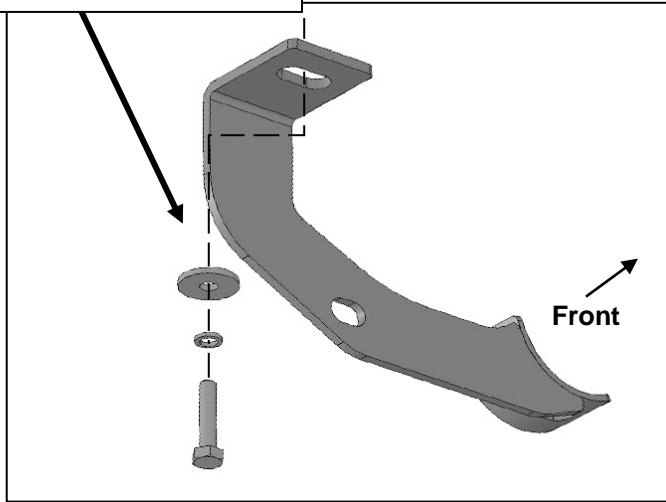

(Fig 3) Attach Driver/left front Mounting Bracket

Attach to factory threaded hole in floor panel



(Fig 4) Driver/left front Mounting Bracket installed

- (2) 6mm x 25mm Hex Bolts
- (4) 6mm Flat Washers
- (2) 6mm Nylon Lock Nuts

- 10mm x 30mm Hex Bolt
- (2) 10mm Flat Washers
- 10mm Nylon Lock Nut

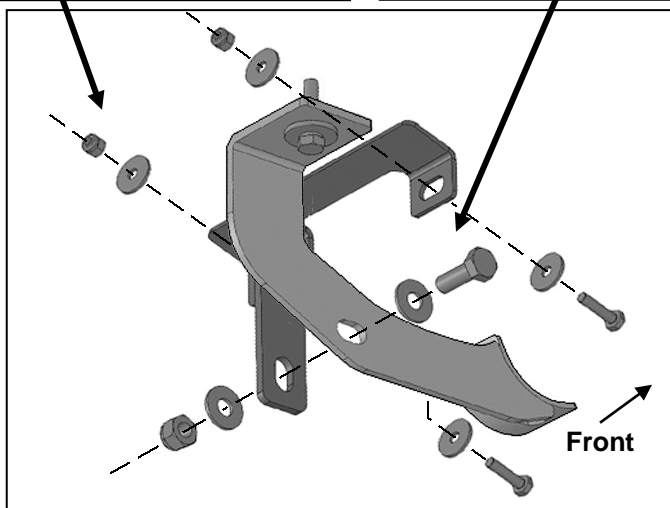

(Fig 5) Attach top of driver/left Support Bracket to back of pinch weld



(Fig 6) Driver/left front Brackets installed

Driver/left Side Installation Pictured

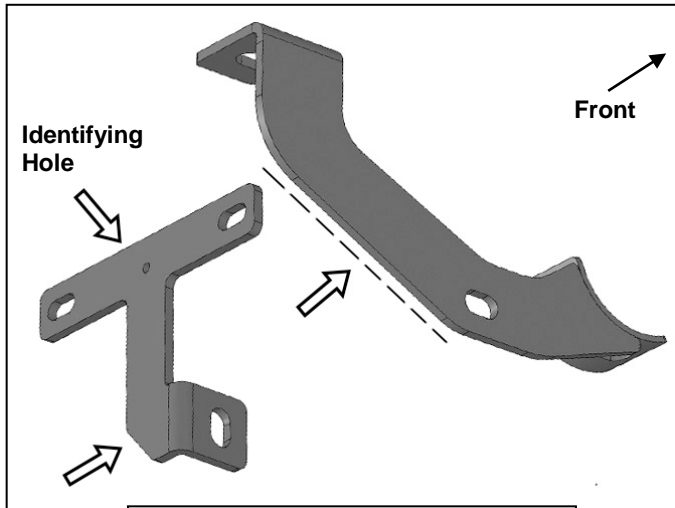

(Fig 7) Driver/left center Mounting and Support Brackets

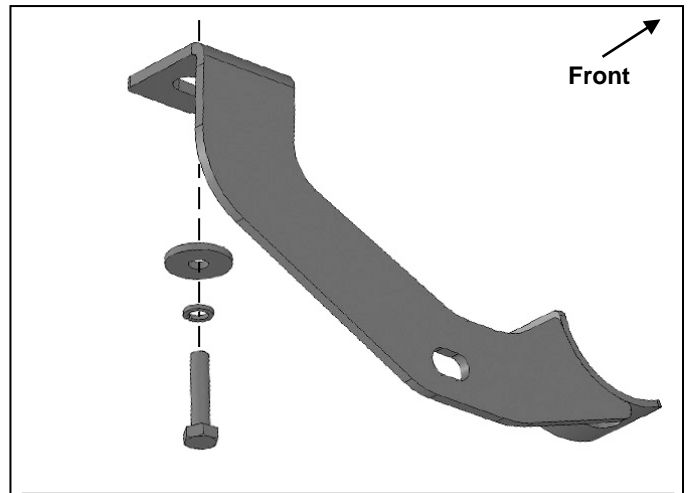

(Fig 8) Attach driver/left Center Mounting Bracket

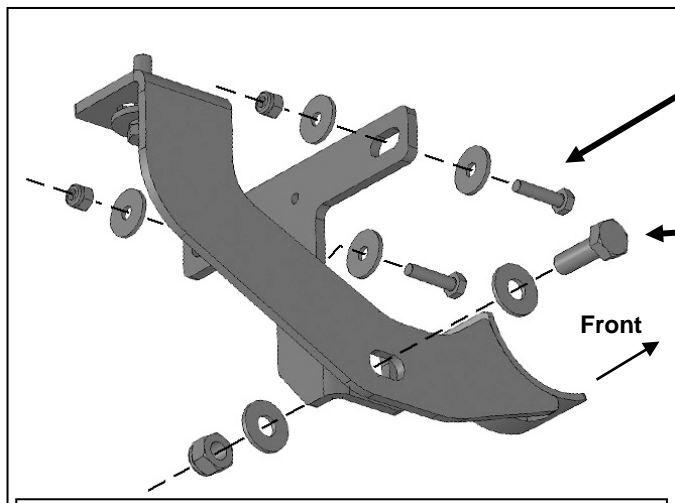

(Fig 9) Attach driver/left Center Support Bracket

- (2) 6mm x 25mm Hex Bolts
- (4) 6mm Flat Washers
- (2) 6mm Nylon Lock Nuts

- 10mm x 30mm Hex Bolt
- (2) 10mm Flat Washers
- 10mm Nylon Lock Nut

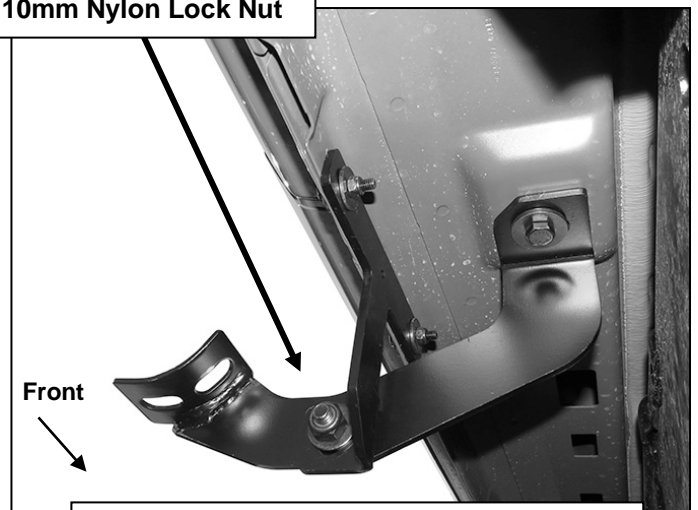

(Fig 10) Driver/left center Brackets installed

Driver/left Side Installation Pictured

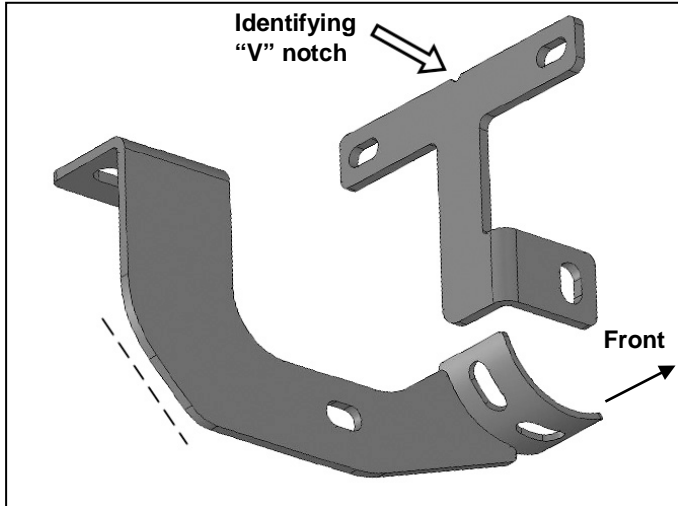

(Fig 11) Driver/left rear Mounting and Support Brackets

8mm x 35mm Hex Bolt
8mm Lock Washer
8mm Flat Washer

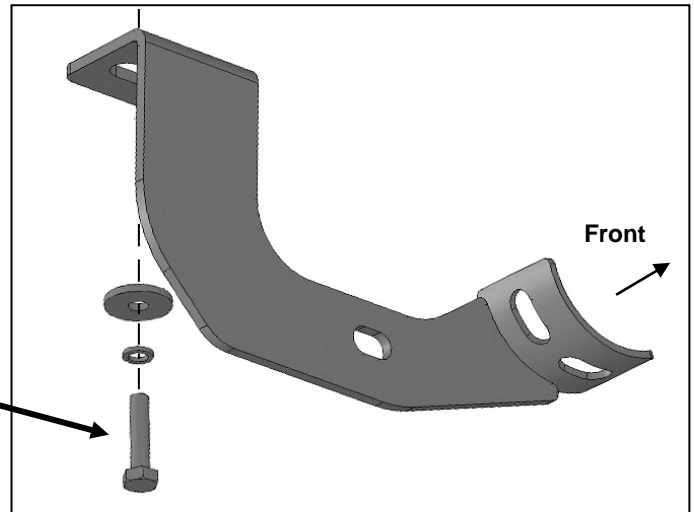

(Fig 12) Attach driver/left rear Mounting Bracket

(2) 6mm x 25mm Hex Bolts
(4) 6mm Flat Washers
(2) 6mm Nylon Lock Nuts

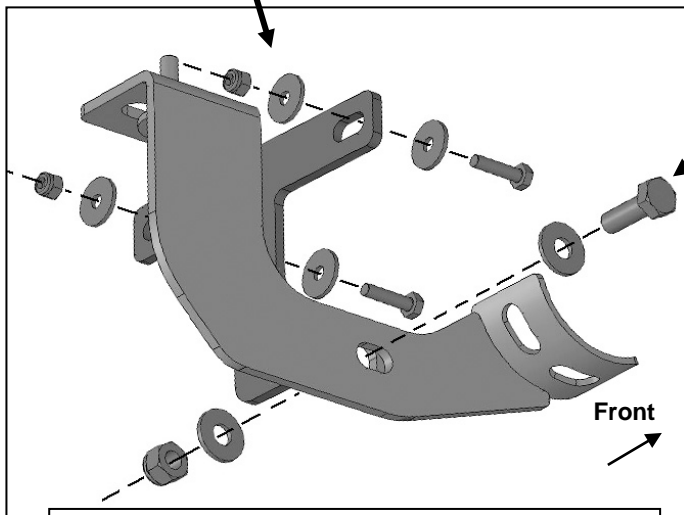

(Fig 13) Attach driver/left rear Support Bracket

10mm x 30mm Hex Bolt
(2) 10mm Flat Washers
10mm Nylon Lock Nut

(2) 6mm x 25mm Hex Bolts
(4) 6mm Flat Washers
(2) 6mm Nylon Lock Nuts

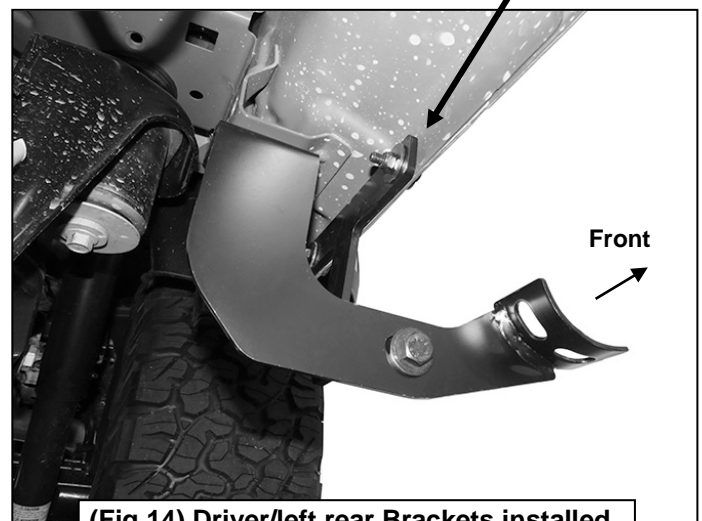

(Fig 14) Driver/left rear Brackets installed

Driver/left Side Installation Pictured

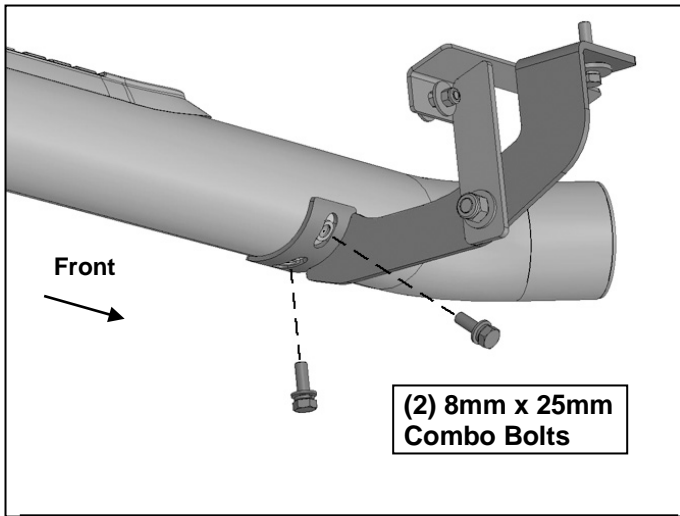

(Fig 15) Attach driver/left Sidebar to front Bracket

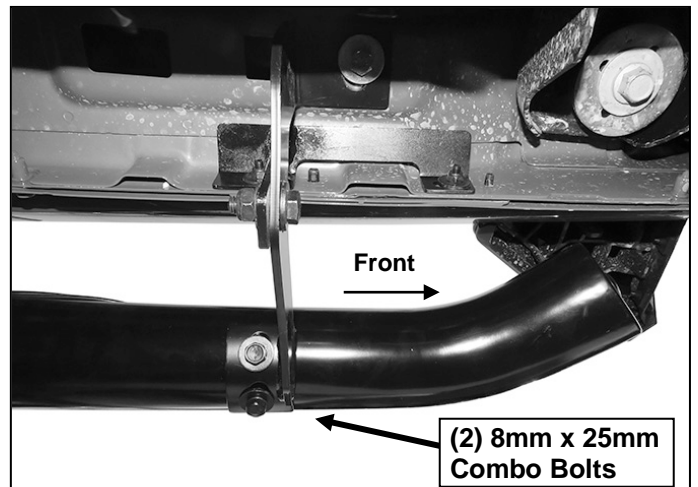

(Fig 16) Attach driver/left Sidebar to front Bracket

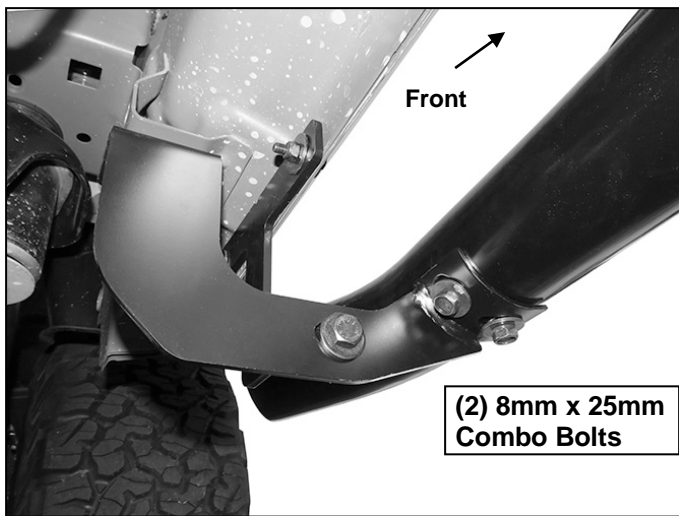

(Fig 17) Driver/left Sidebar attached to rear Bracket

